



City of Detroit
OFFICE OF THE AUDITOR GENERAL
2 WOODWARD AVENUE, SUITE 216
Detroit, Michigan 48226
PHONE: (313) 224-3101
FAX: (313) 224-4091
www.detroitmi.gov

Mark W. Lockridge
AUDITOR GENERAL

MEMORANDUM

DATE: September 22, 2015

TO: Council President Tempore George Cushingberry, Jr.
Detroit City Council

FROM: Mark W. Lockridge 
Auditor General

RE: City Council Special – City of Detroit Public Art

During the June 17, 2015 Budget, Finance, and Audit Standing Committee (Committee) meeting, the Office of the Auditor General (OAG) was requested to perform an audit of the City of Detroit's public art other than the art held by the Detroit Institute of Art. More specifically, the Committee was interested in whether or not there exist a comprehensive listing of all such art, and if in fact the art is own by the City or some other party. This memorandum is our response to the Committee's request.

We contacted several entities in an attempt to gather a listing of the City of Detroit's public art. Based on those contacts, we discovered the following:

- The OAG contacted the Detroit Institute of Arts (DIA). The DIA indicated that there are three DIA art objects located throughout downtown Detroit. Those art objects are the Joe Louis bronze fist located at Woodward and Jefferson Avenues, the Abraham Lincoln marble bust located in the garden next to the Veteran's Memorial Building, and the Madame de la Mothe Cadillac Memorial bronze tablet located in the Cadillac Square People Mover station. In addition, the DIA provided a website link for the website titled "Detroit Public Art and Sculpture." However, the website included some art objects that were not located in the City of Detroit proper. Furthermore, a number of the listed art objects were located on private property, which calls into question the ownership of the art objects. (See Attachment I for website printout)

- The OAG contacted the Recreation Department. The Recreation Department provided us with a 265-page document that noted statues and monuments located in City of Detroit parks along with statues and monuments located on City of Detroit public property. The information contained in the document was dated. The Recreation Department indicated that they were in the process of updating the publication prior to the City's bankruptcy. (See Attachment II for the Recreation Department publication)
- The OAG contacted the Detroit-Wayne Joint Building Authority (DWJBA). The DWJBA provided us with a list of art objects located in and around the Coleman A. Young Municipal Center. The list indicated that the City of Detroit owned four items, specifically the portraits of Mary V. Beck, Erma Henderson, and Maryann Mahaffey, and the Seal of the City of Detroit. In addition, the DWJBA list indicated twenty-one items the DWJBA either owned or possessed including the Spirit of Detroit statue. The list noted Wayne County as the owner of two objects on the list. A DWJBA representative stated that the owners with the proper documentation could claim the objects listed as DWJBA owned or possessed; therefore, the ownership of the listed objects is in question. (See Attachment III for the DWJBA list of art objects)
- The OAG contacted the Finance Department Capital Asset Management representative. They provided us with a list of objects located at the Detroit Historical Museum. The problem with the list was the DRMS Capital Asset module did not list the objects individually. The DRMS Capital Asset module listed the objects by category.

Based on our research and review of the available data, we have yet to locate a comprehensive listing, which includes all of the public art owned by the City of Detroit.

Section VI of Finance Directive 95 regarding Conducting Physical Inventory of Capital Assets requires that each department shall perform an inventory update of their capital assets at least annually before the end of the year and reconcile to the Oracle Capital assets inventory report. It defines the capitalization threshold and depreciation methodology for major classes of assets including Rare Materials, Works of Art and Historical Treasures as collections or individual items of significance that are owned by a City department or agency which are not held for financial gain, but rather for public exhibition, education or research in furtherance of public service. All rare materials, works of art and historical treasures acquired or donated will be capitalized as of July 1, 2001 unless held for financial gain.

It is our recommendation that the Recreation Department complete its process of updating the art publication and submit the new listing to the Mayor and City Council. We recommend also that the Recreation Department or a department designated by the Administration to consolidate, update, and maintain a listing of all public art objects owned by the City of Detroit, regardless of where it is located.

ATTACHMENT I

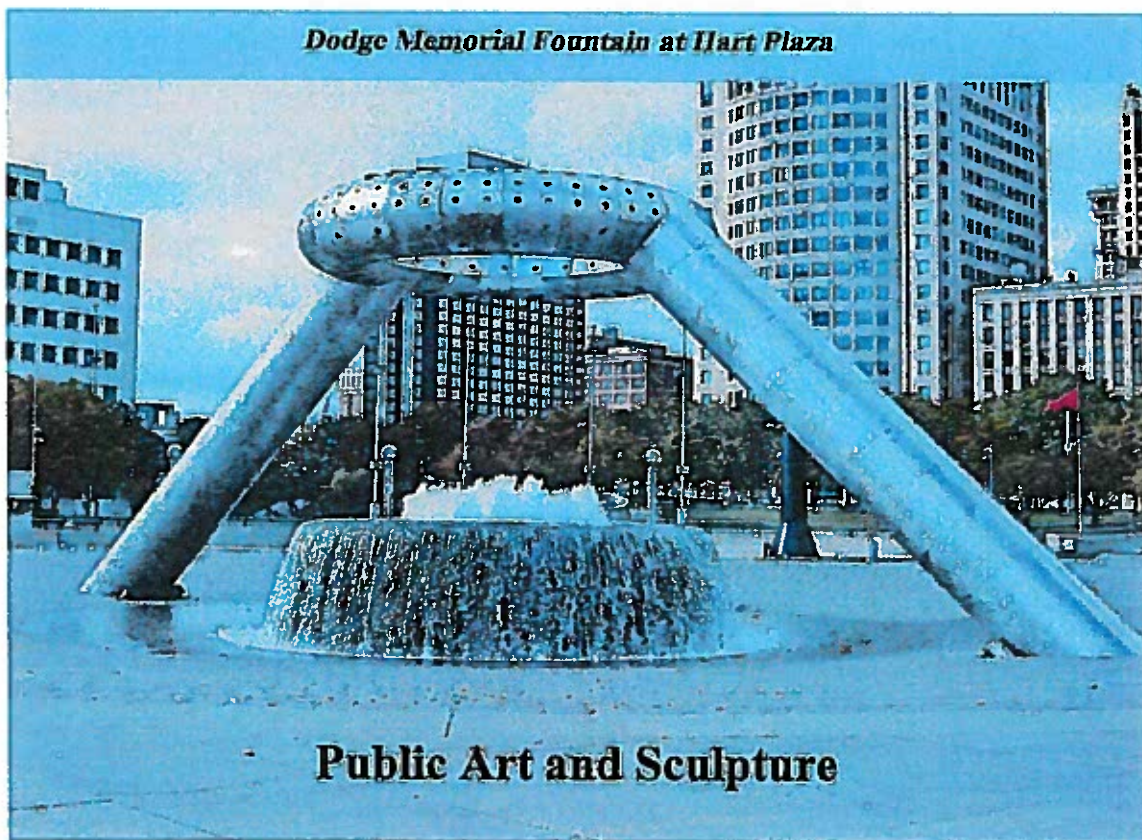

Russell Alexander Alger Memorial Fountain

Ashtabula

Atom Gazelle

John J. Bagley Memorial Fountain

Levi L. Barbour Memorial Fountain

*Battle Creek Underground
Railroad Sculpture*

Boogaloo

Book-Cadillac Sculptures

James J. Brady Memorial

Brightmoor World War II Memorial

Nancy Brown Peace Carillon

Robert Burns Statue

*Disembarkment of Antoine de Lamothe
Cadillac at Hart Plaza*

*Pere Jacques Marquette Statue from
Detroit City Hall*

Stevens T. Mason Statue

Merrill Fountain

Midmien Sculpture

Millennium Bell, Grand Circus Park

*Monroe Monument Marker/
Woodward Monument Marker*

Mozarabe

Hal Newhouser Statue

Nordkyn

Normanno Wedge I

Nymph and Eros

*Commodore Oliver Hazard Perry's
Canons*

Pewabic Pottery

- Antoine de la Mothe, Sieur de la Cadillac Detroit City Hall Statue*
- Father Solanus Casey Statue*
- Bust of Lewis Cass*
- Rene-Robert Cavalier, Sieur de la Salle Statue from Detroit City Hall*
- Ty Cobb Statue*
- Bust of Christoforo Columbo*
- Bust of Christopher Columbus*
- Continuity Tower*
- George Armstrong Custer Equestrian Monument*
- Dancing Maidens*
- Dante Statue*
- Detroit Evening News Sculpture*
- Detroit RiverWalk*
- Passo di Danza*
- Dodge Fountain at Hart Plaza*
- Thomas Alva Edison Memorial Fountain*
- The Entrance*
- Henry Ford Statue*
- Josephine Ford Sculpture Garden*
- Free Form 5*
- Gazelle, Belle Isle*
- Charlie Gehringer Statue*
- Golden Eagle Sculpture, Detroit Zoological Park*
- Goddess of the Golden Thighs Statue*
- Gracehoper*
- Grand Army of the Republic Memorial*
- Grand Couple*
- Phylon*
- Mayor Hazen Pingree Statue*
- Pope John Paul II Statue*
- Brigadier General Casimir Pulaski Statue*
- Starting Point of the July, 1967 Race Riot*
- Horace H. Rackham Memorial Fountain*
- Father Gabriel Richard Statue, Gabriel Richard Park*
- Father Gabriel Richard Statue from Detroit City Hall*
- River of Knowledge Mosaic*
- Johann Schiller Statue*
- James Scott Fountain*
- Sentinel X Sculpture*
- Shinola Detroit*
- Side Talking Kay*
- The Reverend Samuel Francis Smith Memorial Flagpole*
- Michigan Soldiers and Sailors Monument*
- Spanish-American War Commemorative*
- The Spirit of Detroit*
- Spirit Renewal*
- Sunbeam Sculpture*
- The Thinker*
- Trilogy Sculpture*
- Tower of Freedom*
- Harriet Tubman Statue*
- Underground Railroad Statuary and Memorial*

Hank Greenberg Statue
Johannes Gutenberg Statue
Hand of God Sculpture
Ernie Harwell Statue
Heidelberg Project
Helios Trail
Hip and Spine Stone Chair Setting
Willie Horton Statue
Mayor Orville Hubbard Statue
Chauncey Hurlbut Memorial Gate
Jeune Fille et sa Suite
Al Kaline Statue
Father Clement Kern Statue
Bust of Dr. Martin Luther King, Jr.
Bust of Mikolaj Kopernik
General Thaddeus Kosciuszko Statue
*Commemoration of the American
Labor Movement Statue*
Leaping Gazelle
Le Fleuve et La Garonne
Abraham Lincoln Statue
Little Water Girl Statue
William Livingstone Lighthouse
Memorial to Joe Louis
Joe Louis Statue
Ludington Place Statues
William Maybury Statue
General Alexander Macomb Statue

*Underground Railroad Monument,
Canada*
United Foundation Torch
*Untitled Sculpture Honoring
Professor Andrzej W. Olbrot*
Untitled Sculpture on Belle Isle
*Untitled Fort/Cass
People Mover Station*
Upfront
Father Gomidas Vartabed Statue
Victory Eagle
*Johann Friedrich von Schiller
Sculpture*
George Washington Statue
Anthony Wayne Monument
*Wayne State University
First Sculpture*
*Major General Alpheus Starkey
Williams Statue*
Wings of Learning
*Obelisk Commemorating
Judge Augustus Woodward's
Plan for the City of Detroit*
*Woodward Fountain at
Campus Martius Park*
*Woodward Marker at
Campus Martius Park*
Yoko Ono's Freight Train Statue
Demetrius Ypsilanti Bust

ATTACHMENT II

CITY OF DETROIT PUBLIC MONUMENTS

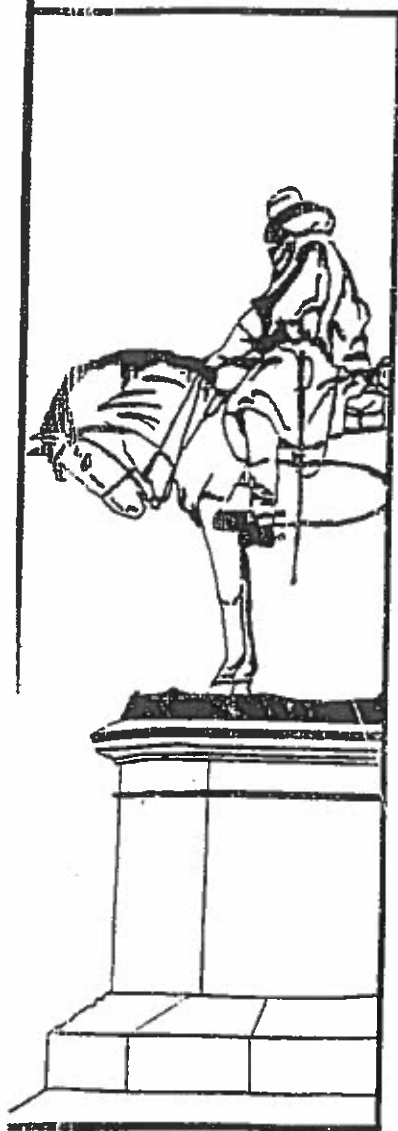

STARKEY WILLIAMS

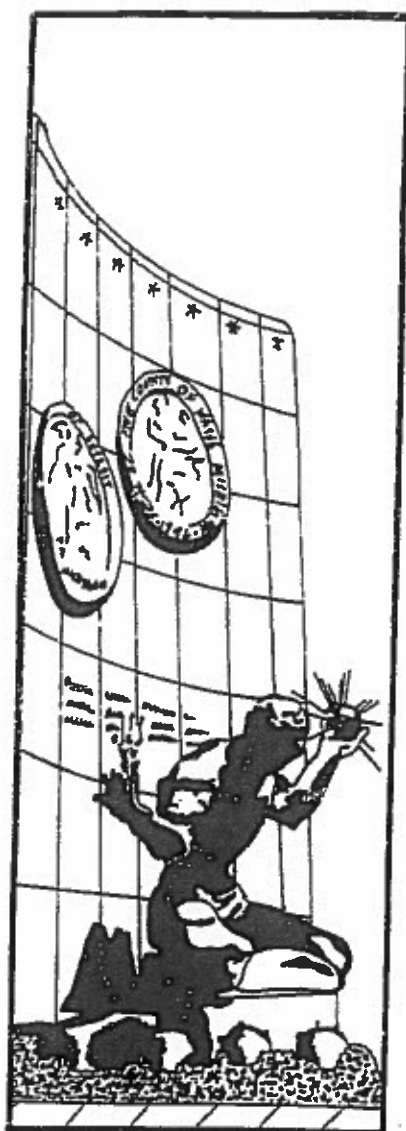

THE SPIRIT OF DETROIT



SOLDIERS and SAILORS

I. STATUES AND MONUMENTS

- Richard Allen Monument
- Robert Burns
- Albert Eugene Cobo, Bust & Plaque
- Christopher Columbus
- Dr. Joseph De Horatiis Monument
- Egyptian Figures
- Le Fleuve La Garonne
- Hand of God
- Hurlbut Memorial Gate
- Martin Luther King, Jr.
- Nikolaj Kopernik (Nicolaus Copernicus)
- Thaddeus Kosciuszko
- Marquis de Lafayette
- Large Boulder
- Abraham Lincoln (Library Park)
- Abraham Lincoln (Rose Garden)
- Joe Louis I
- Joe Louis II
- Joe Louis III
- General Alexander Macomb
- Steven T. Mason
- William Cotter Maybury
- Monastery Bell
- Hazen Pingree
- Pterodactyl
- General Casimir Pulaski
- Father Gabriel Richard Monument
- Soldiers and Sailors Monument
- Spirit of Detroit
- Spirit of Transportation
- Gomidas Vartabed
- Victory & Progress
- Victory Eagle & Pylons
- General George Washington

Statues, Monuments, & Fountains
II. BELLE ISLE PARK SCULPTURES

- Dante Alighieri
- Levi L. Barbour Fountain
- James J. Brady Monument
- Le Anse Brownstone Fountain
- Cannon (3)
- Civil War Monument
- Earth Sculpture (Creative Play Sculpture)
- The Gazelle
- International Peace Monument
- *Kolb Monument (Sun dial on granite Base)*
- W.K. Muir Drinking Fountain
- Newsboy and His Dog Drinking Fountain
- JoHann Friedrich von Schiller Monument
- James Scott Statue
- ~~James Scott Fountain~~
- Rev. Samuel Francis Smith Monument
- Spanish - American War Monument
- Major General Alpheus Starkey Williams
- Sun Dial on Granite Base/Kolb Monument
- Japanese Tohro
- Totem Poles

III. MODERN ART

Abz Everything Is Anything

Apparition With A View

Ascension

Bed of Boats

Carnival

Catching Up

Century Of Light

Continuity Tower

The Entrance

Exploration

Hard Edge Soft Edge Sculpture

Lattice Form

Pink Landscape Three Trusses Plus

Pylon

Guy O. Saulsberry Square

Sentinel

Standing Together

Steady

Sundial (Armillary Sphere)

United Foundation Torch

Untitled - Kern Block

Untitled - Parkview Park

Untitled - Virginia Place

IV. FOUNTAINS

General Russell A. Alger Fountain

John Judson Bagley Mem. Drinking Fountain

Horace E. Dodge & Son Mem. Fountain

✓ Edison Fountain

George Jay Maron Mem. Fountain

Merrill Mem. Fountain

Frank G. McInnis Mem. Fountain

Orchestra Hall Fountain

STATUES AND MONUMENTS

RICHARD ALLEN MONUMENT

(1760-1831)

Location: In Richard Allen Park, Grand River and West Chicago Avenues. The monument faces the Ebenezer African Methodist Episcopal Church (5151 West Chicago Avenue).

Sculptor: Oscar Graves
8863 Grand River
Detroit, Michigan 48204
Telephone: (313) 897-6088

Oscar Graves was educated in the Detroit Public School System, attended Cranbrook Academy of Arts, and Wayne State University. He was an instructor in ceramics and sculpture at the Franklin Settlement House. For 13 years he was Chief Assistant to Marshall Fredericks. His gifted talent and extensive training enables him to work with equal proficiency in clay modeling, ceramics, metalcraft and bronze. In 1981, Mr. Graves was commissioned by Bishop Hubert N. Robinson and the Fourth Episcopal District to sculpt the monument of Richard Allen.

Contractor: Wolverine Marble Company
14269 Fleming Avenue
Detroit, Michigan 48212
Telephone: (313) 868-7113

Description: Bronze Tablet containing bronze circle plaque (3-1/2' diameter) onto which is etched head bearing likeness of Bishop Richard Allen; this is mounted on an Andes Black Granite pedestal (6' x 5' by 1' thick) with 1 step in front of pedestal, set into a cement block base.

Plant material and shrubbery installed around base of the Richard Allen Monument was done by the Forestry staff of the Recreation Department.

Inscription: On Bronze Tablet - "Born a slave - founder and first Bishop of the first African Methodist Episcopal Church. Led first organized protest to segregation on American soil in 1787 from St. George Methodist Episcopal Church in Philadelphia, Pennsylvania."

Cost: \$20,000 raised primarily by the Fourth Episcopal District, The Council of Bishops and the Ebenezer African Methodist Episcopal Church.

Dedication: July 31, 1983

Facts about Richard Allen:

Born a slave in Philadelphia on February 14, 1760. Soon he and his entire family were sold to a planter near Dover, Delaware, and Allen's new master allowed him to attend Methodist meetings in Dover. In 1777, Allen was converted to a Christian. A few years later he began to preach to his fellow slaves. Allen was so devoted to his new found faith that he was able to convert his master, who soon after allowed Allen and his other slaves to buy their freedom. In 1787, Richard Allen and his friend Absalom Jones, founded the Free African Society of Philadelphia. Sensing the discrimination that seemed ever prevalent when Blacks became members of predominately White organizations, Allen became convinced that Blacks needed their own building in which to worship. In 1794, Richard Allen organized Bethel Church. In 1816, sixteen independent Black Methodist congregations held a conference in Philadelphia and formed a separate Methodist body, the African Methodist Episcopal Church. Richard Allen was elected Bishop of the new church, and he served with distinction until his death on March 26, 1831.

Department Responsible for Maintenance

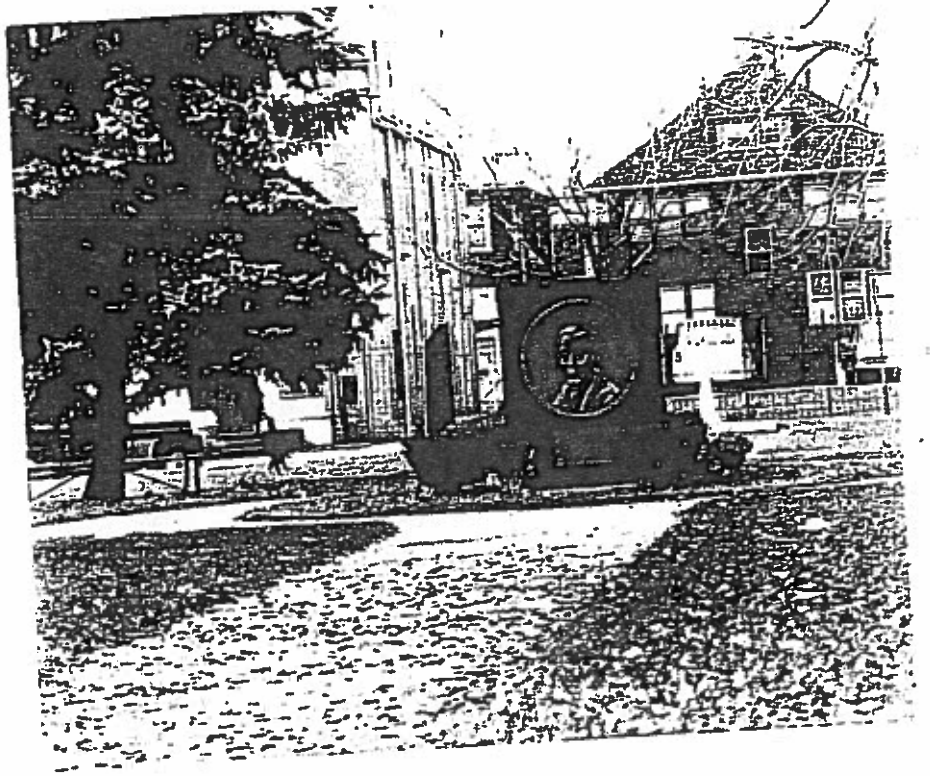
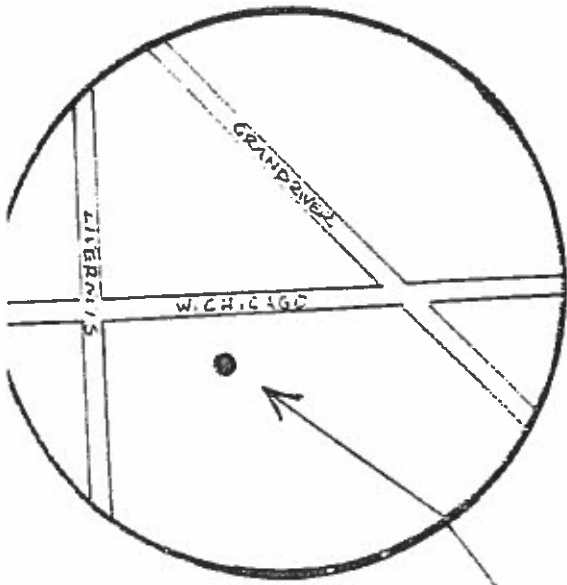

RICHARD ALLEN MONUMENT



ROBERT BURNS STATUE

Location: Cass Park at Second Avenue between Led-
yard Street and Temple Avenue.

Sculptor: George A. Lawson, honorary Royal Scottish
Academician (British).

Biographical/
Information: Very little information can be found on
the Lawson. The original Robert Burns
Statue was unveiled July 11, 1891, in
Ayr, Scotland, after a competition was
held to choose a sculptor.

Material/
Technique: Replica in bronze of the work of art in
the poet Robert Burns' birthplace of
Ayr, Scotland. Bronze cast in England.
New Hampshire granite base.

Size: Bronze figure of Burns is 9 feet high on
a eleven-foot pedestal - total height,
20 feet.

Description: The nine foot Burns is shown as a young
determined man, with arms folded. His
romantic attire---a top coat with long
tails and tight pants---and intense ex-
pression, reflect the artistic mood of
his day.

Inscription: The front of the pedestal contains the
one word "BURNS" in bronze letters,
while on the other three sides are beau-
tiful bronze panels set in granite, rep-
resenting scenes from the poet's life
with appropriate lines inscribed under
each scene.

(on front of base at bottom)

"The highest mead of praise belongs to him who makes a people's songs, who strikes one note, the common good, one chord a wider brotherhood. Presented to the City by the Detroit Burns Club A.D. 1921".

Important
Historical
Facts:

- Robert Burns Statue: Petition #3652, Detroit Burns Club, requesting the permission to erect a statue of Robert Burns in Cass Park granted, and revised plan of pedestal approved by Department of Parks and Boulevards, adopted, J.C.C. 9-14-1920, page 1450.
- Dedicated July 23, 1921, by Detroit Burns Club and Jean Armour Club (Ladies Auxiliary Club). Mr. Edward Goodwillie organized the Burns Club in 1912. Mrs. Goodwillie organized the Jean Armour Club.
- Claims and Accounts: Petition #8139, Detroit Burns Club, requesting City to pay for repairs to Burns Monument, accepted and adopted, J.C.C. 9-12-1939, page 2097.
- Department of Parks and Boulevards: Petition #8139, Detroit Burns Club, requesting City to pay for repairs to bronze tablets, Burns Statue and Controller authorized and directed to honor voucher in amount not to exceed \$30.00 when presented by the Department of Parks and Boulevards, payable to the Western Waterproofing Company, adopted J.C.C. -9-19-1939, page 2167.
- DEPARTMENT OF PARKS AND BOULEVARDS ANNUAL REPORT FOR YEAR 1939 indicates that lacquer removed from Burns Statue and plaques repaired.

Department
Responsible
for
Maintenance:

Detroit Recreation Department.

~~Condition:~~



TUE

6

COBO, ALBERT EUGENE, BUST AND BRONZE PLAQUE

Location: (Civic Center) Cobo Hall - In main level
concourse, Larned, Jefferson Avenue,
Wayne.

Sculptor: Plagen Studios, Inc.

Biographical/
Information:

Material/
Technique: Bronze.

Size:

Description: Bust of former Mayor Albert E. Cobo.
Bust and bronze plaque.

Inscription:

Important
Historical
Facts:

- \$7,720.00---In 1966, money furnished
by the Capital Gifts Committee, De-
troit.
- Albert Eugene Cobo was born on October
2, 1893, and died September 12, 1957.
He was Treasurer of the City of De-
troit from 1935 through 1949. He was
elected Mayor, City of Detroit, in
1949, and for almost eight years from
January 1, 1950, until his death on
September 12, 1957, he served as Mayor
of his beloved city.
- Cobo Hall was named in honor of Albert
E. Cobo by Ordinance No. 248-F, effec-
tive November 28, 1957.
- Total Land Area: 17 acres.
- Excavation begun June 11, 1956.
- First convention in Cobo Hall (Florist
Telegraph Delivery Association) on Au-
gust 12, 1960.

- Cobo Arena Opened April, 1961.
- Cost of Cobo Hall: \$45,000,000.
- Cost of Cobo Arena: \$10,000,000.
- Total: Cobo Hall/Arena: \$55,000,000.
- Largest convention and exhibit facility in the world, Cobo Hall-Cobo Arena fills 17 acres of land in the 75-acre Civic Center, which is located in the hub of Detroit. It enjoys an outstanding view of the world's busiest waterfront-the Detroit River. World acclaim has been lavished upon Cobo Hall and Detroit's Civic Center development.

Department
Responsible
for
Maintenance: *Civic Center Department.*

Condition:

ALBERT E. COBO BUST

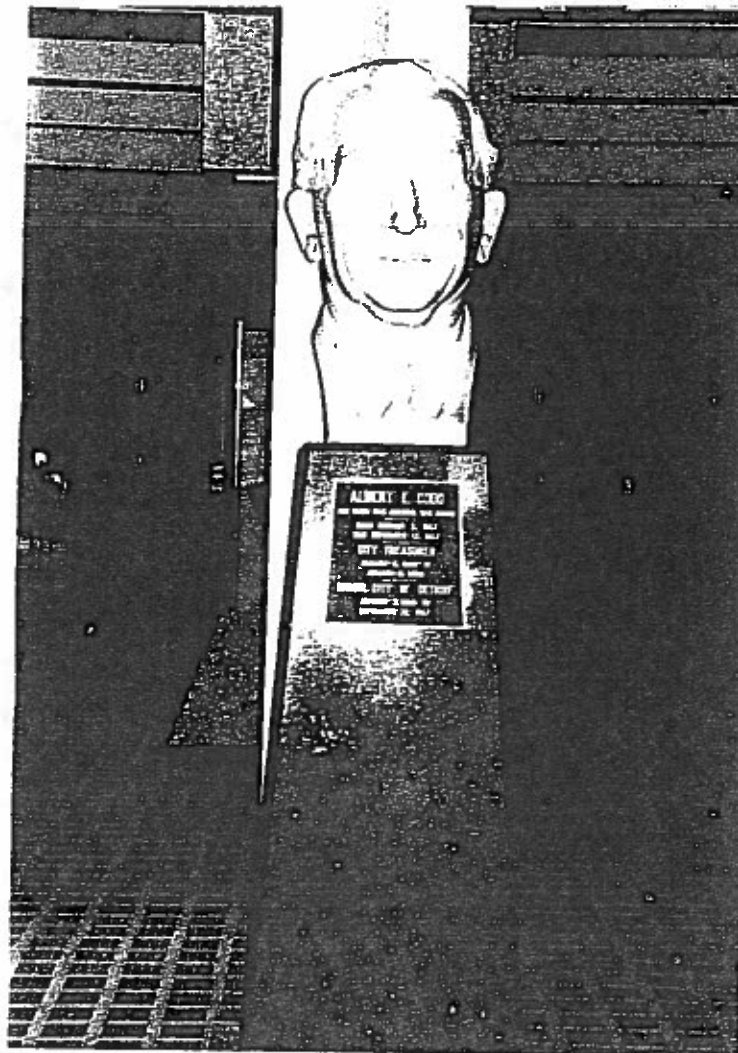
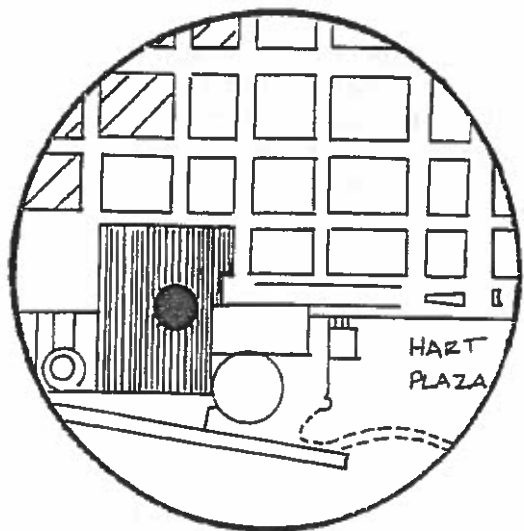

CHRISTOPHER COLUMBUS

Location: This statue was originally located at the north end of Washington Boulevard. It was subsequently moved in October/December, 1987, to the Randolph island at the corner of Jefferson Avenue and Randolph Street.

Sculptor: Augusto Rivalta.

Biographical/Information: 1835-1925. Italian. Notable examples of Rivalta's work stand in the capitol cities of Argentina, Columbia, Brazil, Germany, and Italy. Rivalta was relative of Vincenzo Guiliano, the man who initiated the efforts for the bust of Columbus here in Detroit. The sculptor's son, Carlo Rivalta, sculpted the Dante bust, also owned by the City, located on Central Avenue on Belle Isle Park.

Material/Technique: Cast bronze bust and travertine marble base.

Size: Base: approximately 4'-10" square; ht. 12-3.
Bust: 5'-4" ht., overall ht. 14'-10".

Description: The tall and visionary explorer gazes calmly into the distance. The bust's deeply chiseled and stern features as well as the emphasis on the shoulders add a note of dignity and pride. The elaborate base with the bow and stern of the ship and the heavy foliate cornice add further distinction.

Inscription:

"Christopher Columbus, a great son of Italy. Born 1435 - Died 1506. Discovered America October 12, 1492. This monument is dedicated to his honor by the Italians of Detroit, October 12, 1910."

(A second plaque was added when the monument was relocated to the Randolph island at the corner of Jefferson Avenue. See page 3 for wording of inscription.)

Important Historical Facts:

- The bust was donated to the City in 1910, by the Italian community in and around Detroit. The major force behind the project was Vincenzo Guiliano, editor of the Italian Tribune.
- Materials and shipping costs amounted to around \$2,300, but the sculptor donated his work. The City paid for underground construction.
- On the day of the unveiling, October 12, 1910, a time capsule was placed in the pedestal, but was not found when it was moved in 1987.
- Columbus Day activities take place yearly at the base of the statue.
- In November 1987, the bust and its base were removed for restoration ^{From its location} ~~and~~ ^{It was Relocated} ~~removed to~~ the corner of Jefferson Avenue and Randolph Street following the restoration work. Restoration work was performed by Venus Bronze Works, Inc. A new plaque was installed to replace the one stolen. Also, a new second plaque on the back (northerly) side of the monument ^{commemorate the status rededication} ~~to~~ Once again, the Italian community was involved in these efforts. As a result of efforts of the Central Business District Foundation ~~the~~ ^{4 bollards} lights were added during the relocation construction work.
- The statue will be reinstalled ~~in the old~~ ^{in the old} ~~spring of 1988~~ following completion of the restoration work to the bronze bust and marble base. Rededication ceremonies were held on _____, 1988.

Behind the Trolley garage on the North end of Washington Boulevard.

was

Department
Responsible
for
Maintenance:

Detroit Recreation Department.

~~Condition:~~

~~Excellent.~~

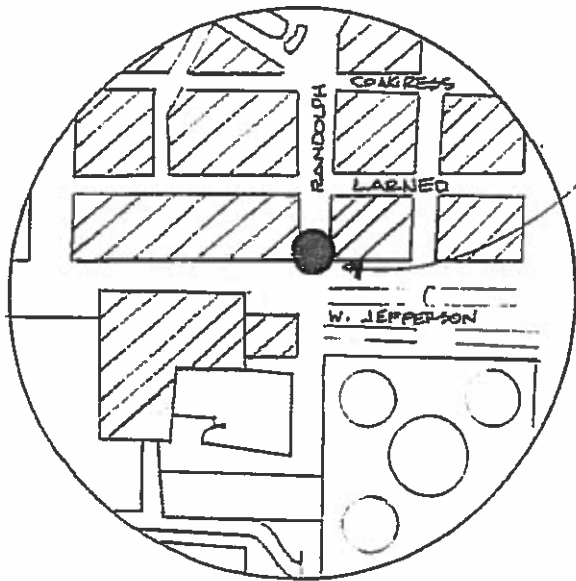

CHRISTOPHER COLUMBUS

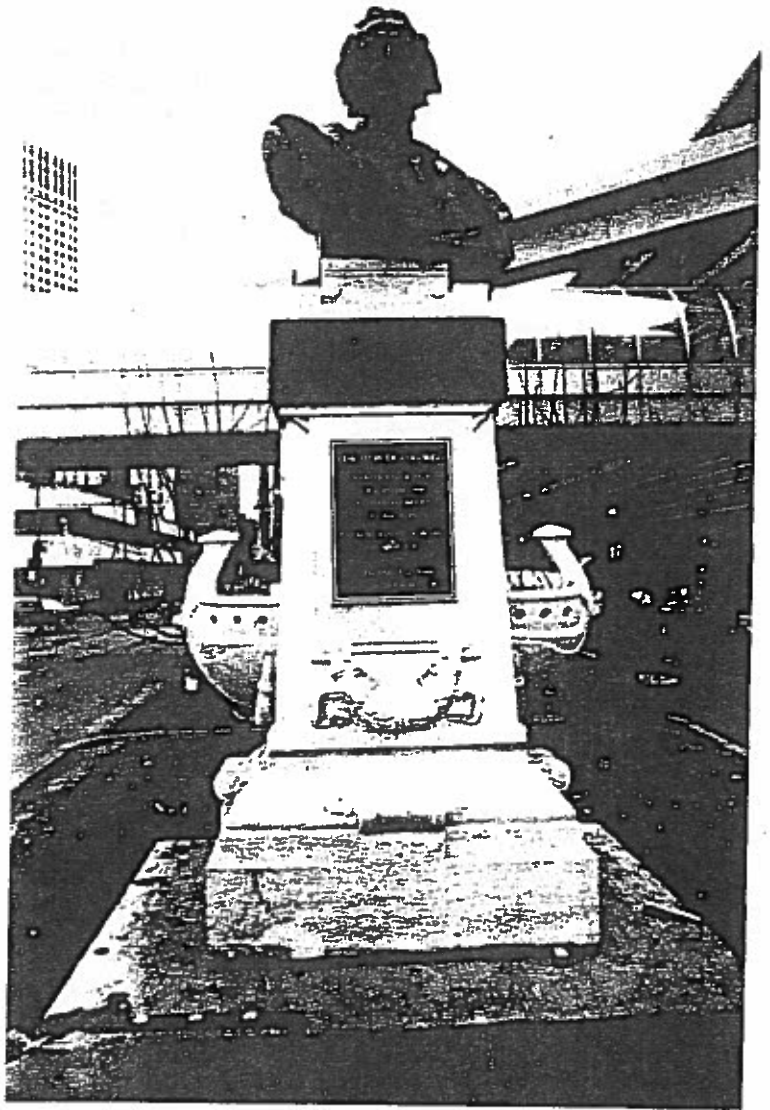

DR. JOSEPH DE HORATIIS MONUMENT

Location: DeHoratiis Parkway in triangular island between Gratiot, Warren and East Grand Boulevard.

Sculptor: City Engineer.

Biographical/
Information: Prepared by City Engineer for monument as a memorial to Dr. Joseph DeHoratiis approved and adopted by Council, J.C.C., page 1259.

Material/
Technique: *granite*

Size:

Description:

Inscription: (front of monument) (cut in letters)

DR. JOSEPH DeHORATIS
Born 1879 Died 1943

With Christian charity he devoted his
life to assuage the suffering of his
fellowmen
his life moved ever upward by dint of
sacrifice
Erected By The Italian-American of De-
troit

1945.

(back of monument) (cut in letters)

Joseph DeHoratiis Parkway.

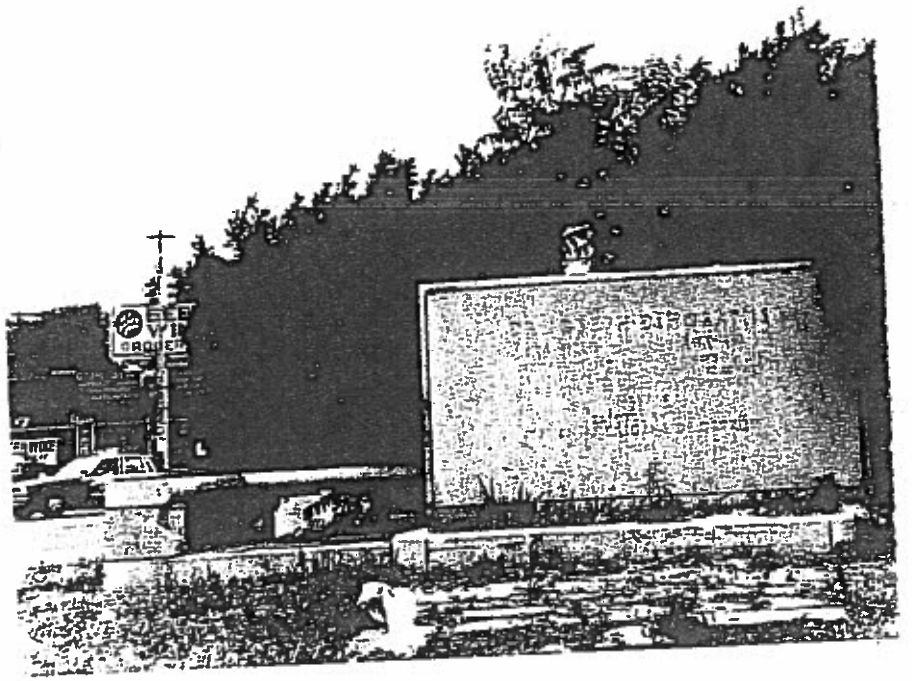
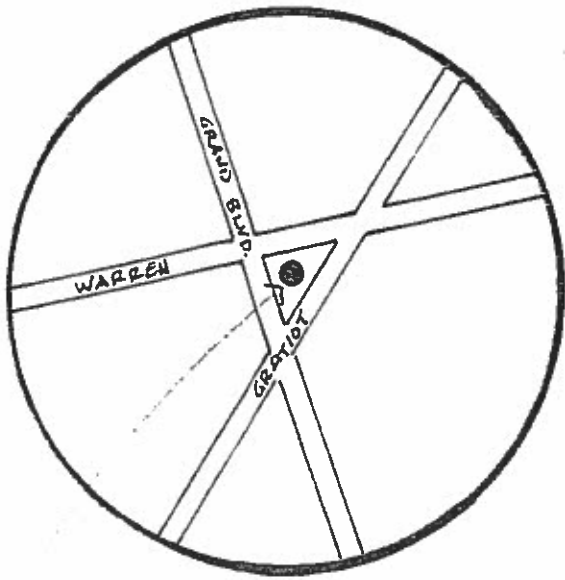

DR. JOSEPH DE HOBATH'S MONUMENT



EGYPTIAN FIGURES

Location: Giraffe House, Zoological Gardens, 8450 West Ten Mile Road, Royal Oak, Michigan.

Sculptor: Joseph Pallenberg.

Biographical/ Information: Pallenberg was from Dusseldorf, Germany, and owned a small zoo himself. These works were done in the early 1930s.

Material/ Technique: Painted and gilded concrete.

Size: *None*

Description: Large frontal, static, Egyptian-style figures flank a painted and carved cement temple structured. The hieroglyphics were also done by Pallenberg.

Inscription: *None*

Important Historical Facts:

--The sum of \$200,000 was allocated by the federal government to the Civil Works Administration to be used for this project from 1930 thru 1934. Pallenberg supervised 1200 CWA workers.

--Artist's statement: "People throughout America will come to see the Detroit Zoo, and they will leave discussing it as much as your factories and high buildings."

Department Responsible for Maintenance:

Zoological *Park Department* Gardens

Condition:

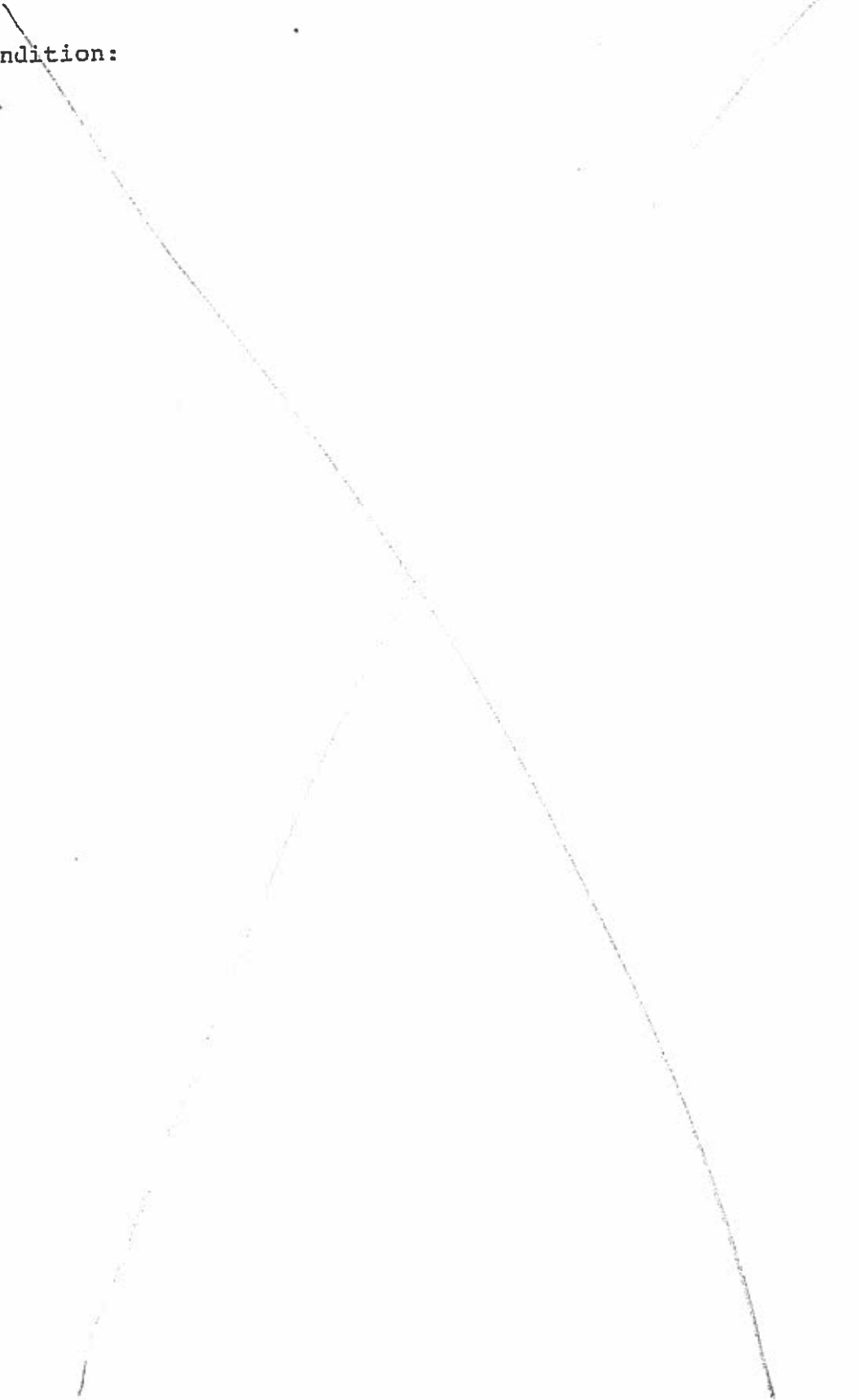

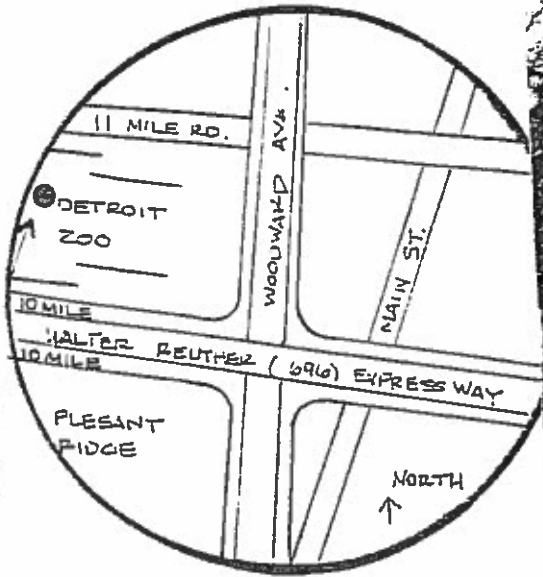

EYPTIAN FIGURES
DETROIT ZOO - GIRAFFE HOUSE



LE FLEUVE LA GARONNE

Location: Woodward Avenue entrance, the Detroit Institute of Arts.

Sculptor: This work was done after a bronze by Coysevox, originally cast by Les Keller in 1688, which now stands in a garden at Versailles outside of Paris, France. This work was cast in the early Twentieth Century.

Biographical/
Information:

Material/
Technique: Cast bronze.

Size: Approximately 53 inches by eight feet by 44 inches.

Description:

Inscription:

Important
Historical
Facts: --Another title variation of the sculpture is the Garonne River.
--The ascension number on the work is 27.383.

Department
Responsible
for
Maintenance: The Detroit Institute of Arts.

~~Condition:~~

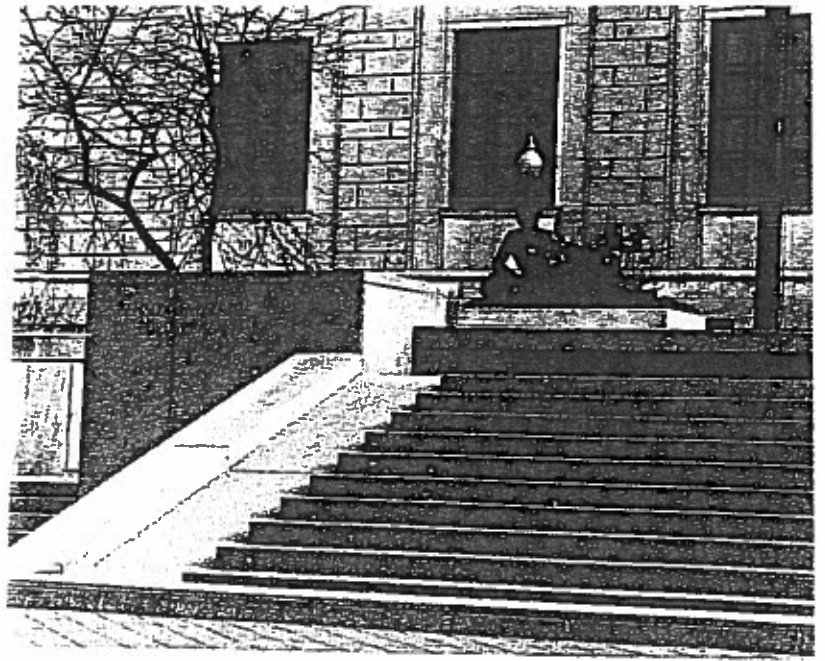
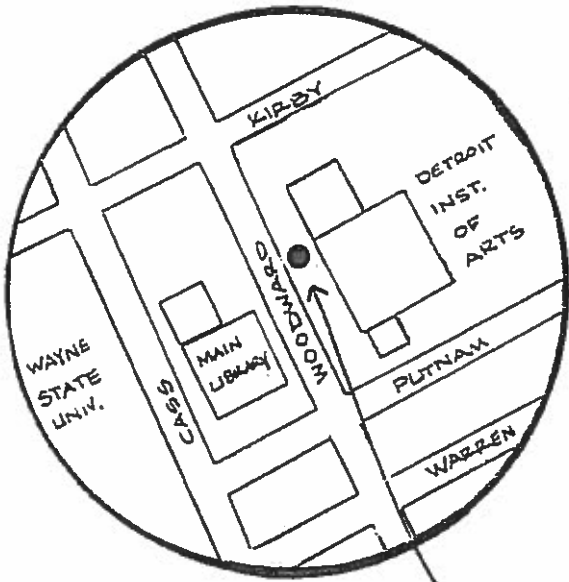

LE FLEUVE LA GARONNE



HAND OF GOD

Location: Frank Murphy Hall of Justice Building,
1441 St. Antoine.

Sculptor: Dr. Carl Milles.

Biographical/
Information:

1875-1955. Educated in Stockholm and Paris, he taught almost until the time of his death in 1955. He was and remains an important contributor to the sculptural scene in Europe and the U.S. His work can be seen in St. Paul Minnesota., D Court, Chicago, Rockefeller Center, NYC, and in many places in Stockholm.

Material/
Technique:

Cast bronze atop a black granite pedestal.

Size:

Approximately 20 ft. tall, the male figure is 10 ft. tall. The monument is placed on a 26' x 26" square pedestal.

Description:

A giant left hand opens upward with fingers apart. On the thumb and forefinger stands a nude youth leaning backwards with arms and fingers played out as if expressing surprise or awe. Milles idea was to show the giant hand of God lifting man up to view the universe.

Inscription:

"HAND OF GOD"
Carl Milles - Sculptor
Presented to The People of Detroit
In Tribute To
FRANK MURPHY
HUMANITARIAN - STATESMAN
ADVOCATE OF JUSTICE
Through The
Generosity of The Members of The

International Union, Automobile,
Aerospace and Agricultural Implement
Workers of America-UAW

Important
Historical
Facts:

- Hand of God was designed in the early 50s by Milles while at Cranbrook, but finished in Rome.
- Detroit's version was cast in Denmark. It was designed to honor C. E. Johansson, who revolutionized precision measuring of auto and other industrial parts, which made the assembly line possible.
- In 1959, then UAW-CIO president Walter P. Reuther, along with former Executive Circuit Judge Ira W. Jayne, choose the Hand of God to memorialize Justice Murphy, as they considered him Michigan's greatest champion of industrial democracy.
- March, 1964, Hand was given to Wayne State University where it was stored until 1970.
- November, 1970, it was installed at its present location. However, elaborate plans for a reflecting pool were abandoned because of cost. *AT THE FRANK B. MURPHY Hall of Justice Near the corner of Beaubien & Gaston.*
- Cost: \$65,000. Paid mostly through UAW locals.

Department
Responsible
for
Maintenance:

Condition:
~~X~~

The bronze base was designed by
local noted Sculpture Marshall
Friedrichs.

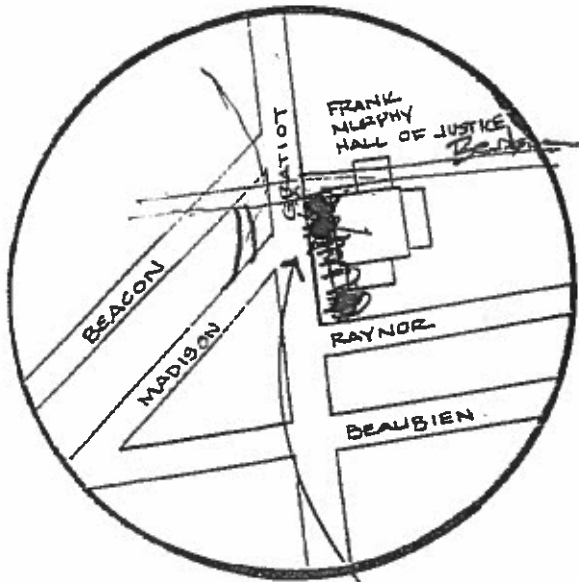

"HAND OF GOD" STATUE.

new photo.



HURLBUT MEMORIAL GATE

- Location:** Entrance to Waterworks Park on East Jefferson Avenue (Gladwin Park).
- Sculptor:** Sculptors and cravers: Reuther, Krako, & Jungwirth. Architect and Designers: G.A. Mueller of Brede (Mueller won first prize for his design).
- Biographical/ Information:** 1865-1937. Gustave Mueller was born in Dresden, Germany, and worked with the French on their unsuccessful Panama Canal project. He came to New York to work under architect Stanford White before joining with Mr. Brede.
- Material/ Technique:** Carved granite and cut masonry.
- Size:** Approximately 50 ft. high x 132 ft. wide.
- Description:** Following the prevailing tastes of the day, a baroque style triumphal arch is raised upon a restricted base and crowned with a slender dome. A grand staircase ascends to a terrace above the central gate. Also, included in the structure at one time were a carved eagle and a bust of Chauncey Hurlbut.
- Inscription:** "Chauncey Hurlbut, appointed Water Commissioner September 16, 1861, served until May 1, 1863; re-appointed May 1, 1872 to the date of his death September 7, 1885. Erected AD MDCCCXCIII."

Important
Historical
Facts:

- Chauncey Hurlbut, an early Water Commissioner, 1803-1885, left almost all of his estate, (almost a quarter of a million dollars) to the Board of Water Commissioners to be expended in maintaining a library and improving the grounds belonging to the Commission.
- April 4, 1893, Commissioners Goebel, Duffield, and Kirby were appointed to select a suitable memorial for Mr. Hurlbut to be placed in the ground at the Pumping Works.
- August 23, 1893, proposals were received and opened for work on the Hurlbut Memorial Gate according to plans and specifications prepared by Brede and Mueller.

--Accepted as follows:

Cut Stone Work	
Felix Meier	\$18,550.00
Mason Work - A. Chapoton	2,082.00
Iron Work - J. E. Bolles and Co.	838.00
Carpenter Work	
J.C. Wallich	200.00
Sheet Metal Work	
Adam Orth	75.00
Painting and Glazing	
Godfrey and Dean	160.00
Carving and Sculpture	
Reuther and Company	5,300.00
Plumbing and Heating	
City Metal Works	61.00
TOTAL COST	<u>\$27,266.00</u>

Department
Responsible
for
Maintenance:

Department of Water and Sewerage
Board
of Commissioners.

Condition:

Needs stone cleaning, tuckpointing and
historic conservation.

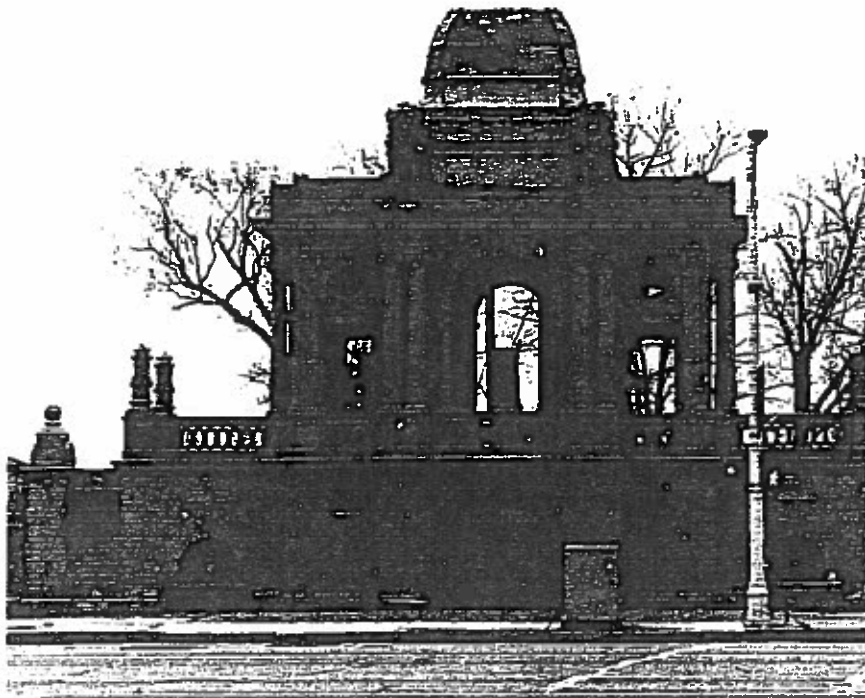
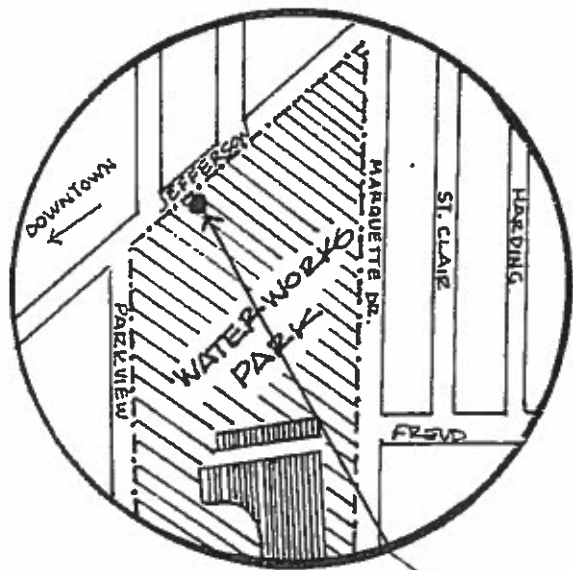

HURLEUT MEMORIAL GATE
(ENCLOSING WATERWORKS PARK)



MARTIN LUTHER KING, JR.

Location: Virginia Park (also known as South Entrance Park "P") was dedicated as Martin Luther King, Jr. Park, northeast corner of Rosa Parks Boulevard (formerly known as 12th Street) and West Grand Boulevard.

Sculptor: Oscar Graves.

Biographical Information: Graves received his post secondary education at Wayne State University and Cranbrook Academy of Art. He continues to work in the area.

Size: Approximately 2 ft., 8 in., mounted on an Andes black granite pedestal base measuring 2 ft. x 2 ft. x 5 ft.

Material/
Technique: Cast aluminum on an Andes black granite base.

Description: The aluminum sculpture features a bust with a likeness of the head of Martin Luther King, Jr.

Inscription:

Important
Historical
Facts:

--A grant of \$23,000 was awarded to Oscar Graves for a bronze portrait of Martin Luther King, Jr. on November 11, 1981.

--On June 16, 1982, an additional \$11,000 was obtained in order to replace the bronze portrait and install the aluminum one now in place.

Department
Responsible
for
Maintenance:

Department
Responsible
for
Maintenance:

Detroit Recreation Department.

Condition:

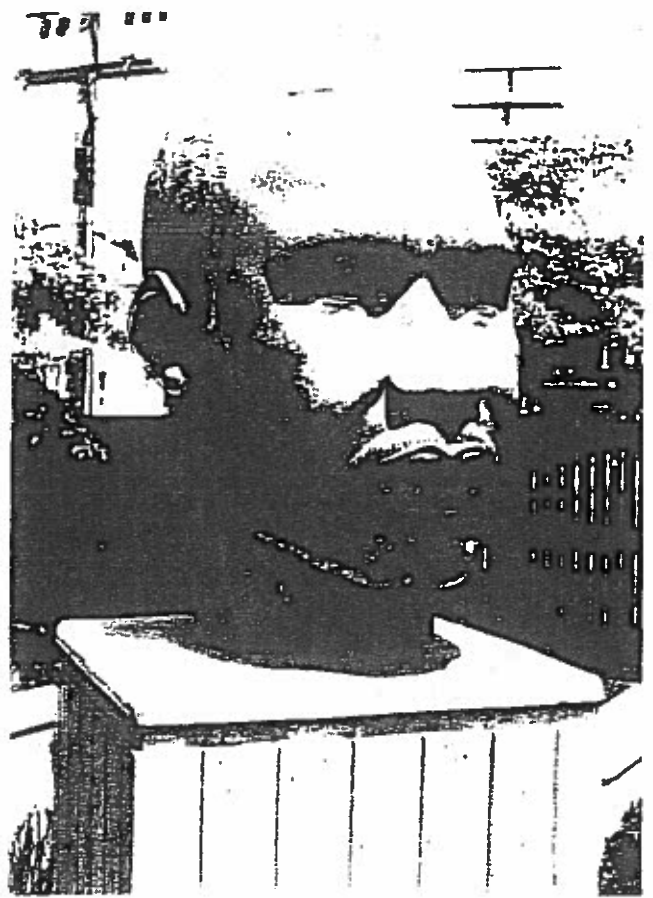

MARTIN LUTHER KING JR.
VIRGINIA PARK

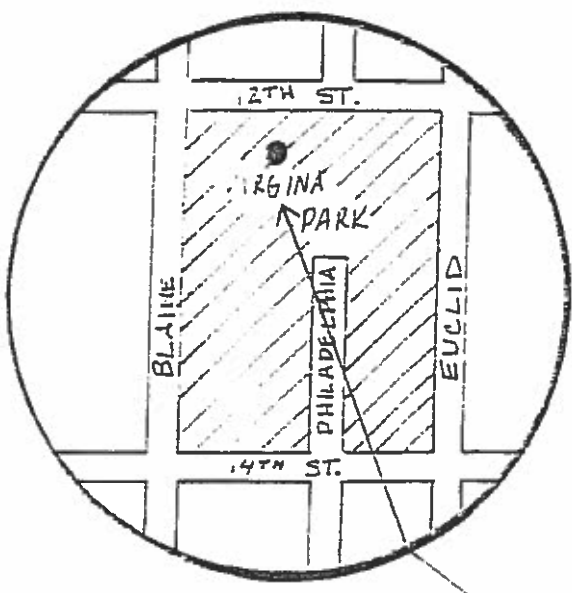

NIKOIAJ KOPERNIK
(Nicolaus Copernicus)

Location: Lawn of the Main Branch of the Detroit Public Library, Woodward Avenue at Kirby.

Sculptor: Ferenc Varga.

Biographical/
Information: 1912- . Born in Budapest, Hungary, the artist resided for sometime in Detroit, but now lives in Florida. At the age of twenty he was awarded the Lord Rothermere Award at the National States Cabinets Exhibition of Art in Hungary, and was assistant professor in Budapest at the Koroly Academy under Jenő Bory. Since that time, he went on to win international acclaim. Other works of Varga's in this area include General Casimir Pulaski and Hamtramck's Pope John Paul II.

Material/
Technique: Bronze and granite.

Size: The bust is 4 1/2 high, 9 times normal volume. The base is 7' high and consists of 8 1/2 tons of solid granite.

Description: The sculpture is a bust of a youthful man with a large nose and sunken cheeks.

Inscription: Nikoiaj Kopernik
Nicolaus Copernicus
1473
To honor and to commemorate
the 300th anniversary of his birth
February 19, 1973

Important
Historical
Facts:

- The work was commissioned April 20, 1971, in honor of the 500 year anniversary of the famous Polish astronomer's birth on February 19, 1473. It was purchased through the donations obtained by the Copernicus Observances Committee, a coalition of nine Polish American organizations in the Detroit area. Bruno Nowicki, Detroit Public Library Commissioner, was executive secretary of the Committee. (Nowicki also collaborated with Varga on the design of Hamtramck's Pope John Paul II sculpture).
- Unveiled February 6, 1973.
- The bust was located in the Cass Avenue entrance of the Main Branch of the Detroit Public Library before being relocated on the lawn later in 1973. A giant crane had to be provided just for the purpose of placing the solid granite base of the work.
- Copies of the original have been presented to every branch of the Detroit Public Library. Also, there is a replica at Alliance College, Cambridge Springs, Pennsylvania, at the Planetarium.
- Cost: \$50,000.
- The artist's son, Frank, a Detroit area sculptor, was commissioned to execute a mosaic of Copernicus for the same occasion. It hangs inside the library.
- Copernicus is primarily known for his discovery that the planets revolve around the sun, not the earth, as previously believed.

Department
Responsible
for
Maintenance:

Detroit Public Library.

Condition:

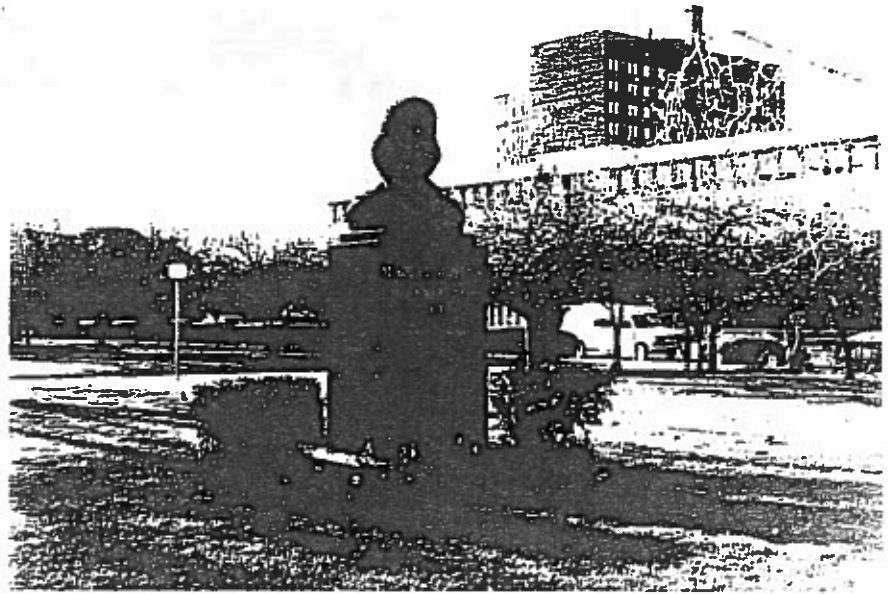
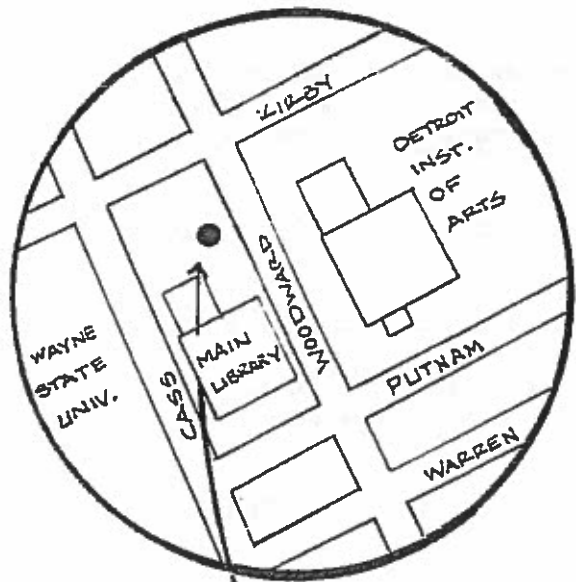

NIKOLAJ KOPERNIK
(NICOLAUS COPERNICUS)



GENERAL THADDEUS KOSCIUSZKO

Artist: The original bronze sculpture was cast in 1889 by Italian artist Leonardo Marconi, and stands at the Wawel Castle in Krakow, Poland. The Detroit replica was cast by Polish artist Victor Zin.

Dates/Country: Original sculptor was Italian. Artist of replica - Polish.

Material/
Technique: Cast bronze on a granite base consisting of five pieces.

Size: Equestrian figure stands 22½ ft. high; with base, over 34 ft. high. Weight of monument, 10 tons. Weight of base - 28-30 tons.

Location: Bagley and Michigan Avenues, between Third and Fourth Avenues.

Description: General Kosciuszko sits upon his prancing horse proudly waving his hat. The T-shaped base bears the inscription of his name.

Inscription: General Thaddeus Kosciuszko.

Important
Historical
Facts: --Monument was a gift from Poland to the United States. Estimated cost - \$640,000. The project was initiated by various Polish organizations in Detroit.
--The cost of the base, erection, and foundation of the monument was approximately \$79,000, paid for by the City of Detroit.
--Ground breaking ceremonies took place on August 14, 1977.
--After a series of delays, the sculpture arrived in July, 1978, from Poland.
--Unveiling - August 13, 1978.

General
Condition: Good.

Department
Responsible: Parks and Recreation.

Extra Notes: See "Press Release," provided in this folder, for a biographical sketch of the General.

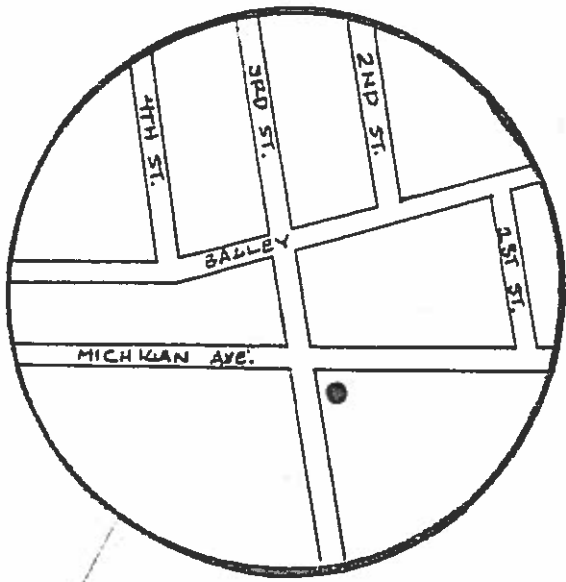

GENERAL THADDEUS KOSCIUSKO



MARQUIS de LAFAYETTE

Location: Originally this work was located on the southeast corner of Lafayette Boulevard and Beaubien on Blue Cross/Blue Shield property. It is now missing.

Sculptor: This is a replica of an original sculpture done by the 18th Century French artist Jean Antoine Houdon.

Biographical Information: 1744-1828. Houdon was a very successful French portraitist of his time, and worked in Rococo and neoclassical styles which were popular during the Napolenic period. He was famous for his perceptive realism which captured the personality of his subjects.

**Material/
Technique:** Cast bronze.

Size:

Description: The bust sits on a miniature bronze pedestal which rests on a larger marble veneer base. Lafayette is depicted in romantic garb with a high collar. The face, hair, and richly varied surface highlight a man engrossed in thought.

Inscription:

**Important:
Historical
Facts:** --July 24, 1976DDDthe bust was presented to the City of Detroit as a gift from France, in celebration of Detroit's 275th birthday and the 200th Anniversary of the United States. French Ambassador M. Jacques Kosciusko-Morizet formally presented the piece to Mayor Coleman A. Young.

- November 1979DDDthe sculpture was moved from the front of the Blue Cross/Blue Shield Building to the southeast corner of Lafayette Boulevard and Beaubien. Marshall Fredericks was awarded the contract to fabricate and install a marble veneer pedestal. Fredericks paid for the bronze identification plaque.
- November 1980DDDthe bust was stolen. Craig Smith, vice president of Sullivan-Smith, Inc. a real estate company posted a \$1,000 reward for its return.
- Marquis de Lafayette was a French General in the American Revolution.

Department
Responsible
for
Maintenance:

Detroit Recreation Department.

Condition:

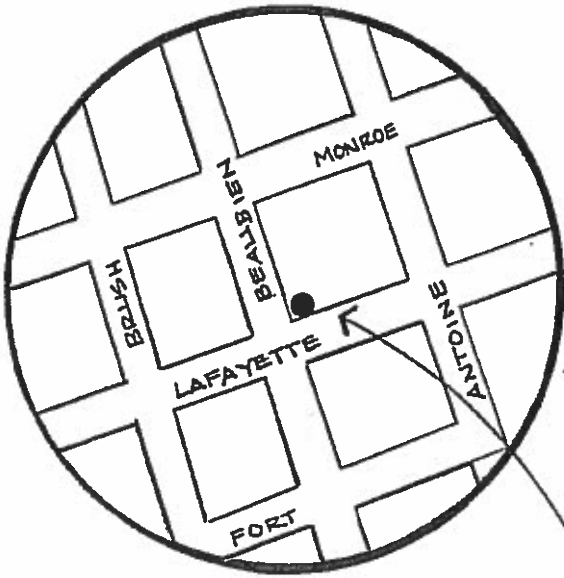

MARQUIS de LAFAYETTE
(NOW MISSING)



LARGE BOULDER

Location: Palmer Park - West of Log Cabin.

Sculptor: Unknown.

Biographical/
Information:

Material/
Technique:

Size:

Description: Large boulder on good foundation showing where sun dial (presumably) was previously located.

Inscription:

Important
Historical
Facts:

Department
Responsible
for
Maintenance:

Condition: Good.

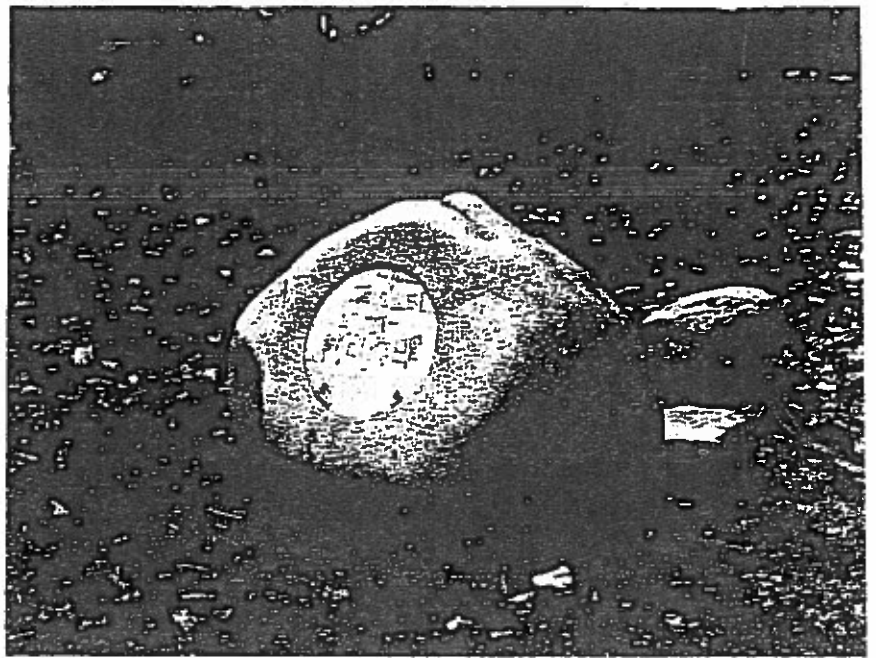
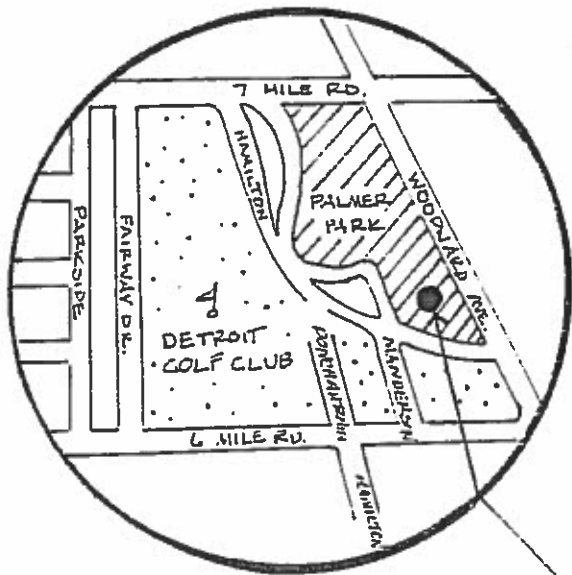

LARGE BOULDER
PALMER PARK



ABRAHAM LINCOLN

- Location:** Library Park on the grounds of the Downtown Branch of the Detroit Public Library, Library and Farmer Streets.
- Sculptor:** Alfonso Pelzer. Mullins Manufacturing Co., Salem, Ohio.
- Biographical Information:** Alfonso came from Germany along with his brother, Hubert, and went into business manufacturing plaster molds in the 1890s. Alfonso probably died in 1922. The original Lincoln was cast in 1898, the Detroit Lincoln in 1915.
- Material/Technique:** The construction of the Pelzer Lincoln was very different from the usual process of bronze casting at the turn of the century. Metal sheets were hammered into shape over dies which had been formed from an original wax mold made by Alfonso Pelzer. The various sections were taken soldered or riveted together, and finally the seams were plated. The result was a lighter and less expensive work of art; subsequently, by 1986, it had deteriorated to the point where holes are visibly plain.
- Size:** Approximately 7 feet in height.
- Description:** Lincoln is shown with his left foot slightly advanced and with his open right hand extended in a low gesture. His left hand holds a half unrolled scroll containing the Emancipation Proclamation.
- Inscription:** The plain limestone base contains the words "Let Man Be Free."

Important
Historical
Facts:

- At the beginning of this century, a number of businessmen in the automobile industry dreamed of the creation of a nationwide network of roads designed for auto traffic. They called themselves the Lincoln Highway Association and their president was Henry B. Joy, president of the Packard Motor Company.
- In 1913, Carl Fisher (from Salem, Ohio) suggested the construction of the three-thousand-mile Lincoln Highway spanning the United States from coast to coast. A number of the bronze Pelzer Lincolns were eventually placed along the route.
- In 1915, William H. Mullins, whose foundry was located in Salem, Ohio, reproduced the Lincoln statues from the Pelzer molds and bestowed two of the statues to the Detroit area. Henry B. Joy received the Lincoln which now resides at the Charles Howell Boy Scout Reservation in Brighton, Michigan, and Henry M. Leland, President of Lincoln Motor Company, received the one now owned by the City of Detroit, Michigan.
- In 1957, Wilfred C. Leland, son of Henry M. Leland, donated the Lincoln statue which for years had stood in front of the old Lincoln Motors Plant on West Warren Avenue to the City of Detroit. It was placed behind the Downtown Branch of the Detroit Public Library.
- Unfortunately, vandals in 1969, broke off the upper portion of the statue, leaving only the feet attached to the monument base. Repair work was done by using steel reinforcement and extensive welding which with the passage of time resulted in further deterioration due to the dissimilar metals reacting to each other.
- References: Downtown Branch of the Detroit Public Library.

--In 1986, local columnist Neal Shine of the DETROIT FREE PRESS mounted a public donation campaign to restore this statue. Historic conservation work was performed by Venus Bronze Works, Inc. and same was rededicated at a ceremony held on July 14, 1986.

Department
Responsible
for
Maintenance:

Detroit Public Library.

Condition:

Restoration contract included rewaxing maintenance through 1987, by Venus Bronze Work, Inc. Current condition is excellent. Base Needs cleaning (noted by Richard G. Hautau, Chief of Landscape Architecture of the Detroit Recreation Department).

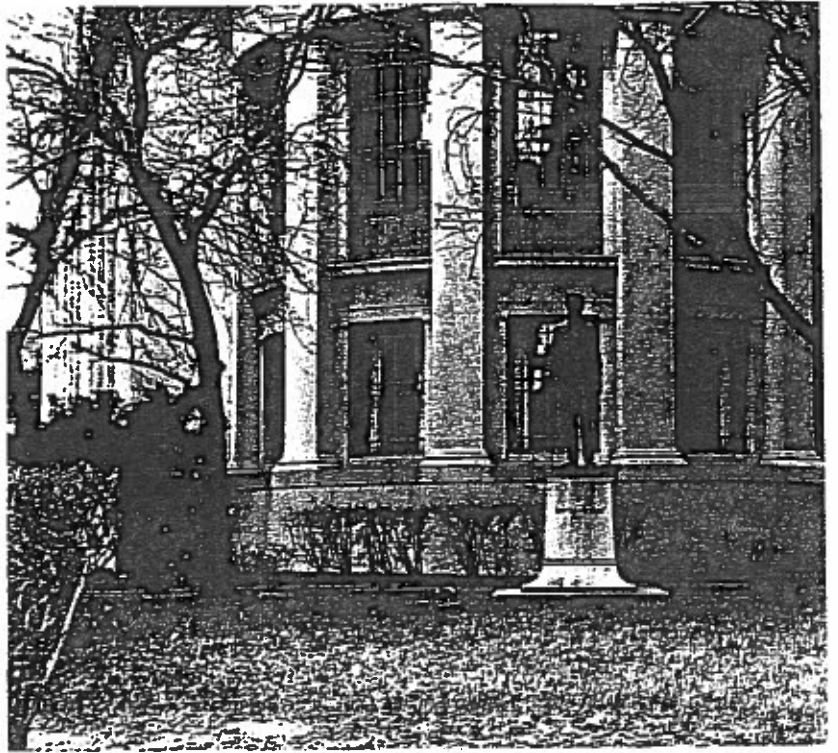
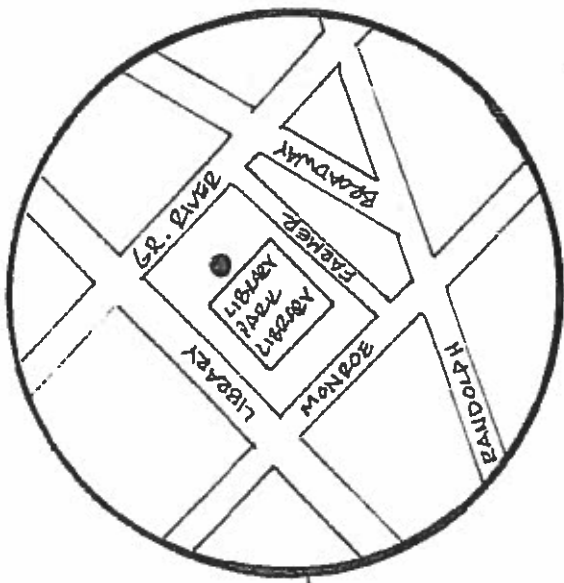

ABRAHAM LINCOLN
LIBRARY PARK



ABRAHAM LINCOLN

Location: Relocated from D.I.A. storage warehouse to the east side of the Veterans Building in the Rose Garden area adjacent to Hart Plaza in 1977.

Sculptor: Gutzon Borglum (John Gutzon de la Mothe Borglum).

Biographical Information: 1867-1941. Borglum was born on March 25, 1867, near Bear Lake, Idaho, and is best known for his colossal portraits on Mt. Rushmore, South Dakota. He studied with Virgil Williams and William Keith in Kansas, before venturing to Paris in 1890, where he studied at Ecole des Beaux-Art and was a close friend of Auguste Rodin. Yet, he believed in doing American art rather than imitating what he saw abroad, and it was this conviction which brought him home in 1902. More and more, the sense of the vastness of America and her importance to the rest of the world impressed him, leading him to experiment with monumental sculptures of American heroes. The first large sculpture came out of a six ton piece of marble and featured Abraham Lincoln. This work now stands on the Capitol grounds in Washington D.C., and won him significant praise. As a result of this acclaim, he proceeded to make a plaster cast of Lincoln to be produced in bronze. Then, two years later, Borglum carved a smaller original for himself, which now stand in Detroit. In 1941, not yet finished with Mt. Rushmore, Borglum died.

Material/Technique: Carved carrara marble.

Size: Total height, 72 inches. Weight, 4 1/2 tons.

Description:

This bust of Abraham Lincoln is roughly hewn from the neck down, shows Borglum's ability to transform marble into life-like surfaces. The first Lincoln done by Borglum so impressed Abe Lincoln's son, Robert, that he said, "I never expected to see my father again."

Inscription:

1918 (on sculpture).

Important
Historical
Facts:

- Provenance: Formally in the collection of Samuel P. Colt of Providence, Rhode Island.
- Donated by Mr. Ralph Booth in 1924 to the D.I.A.
- Lincoln was installed on the museum grounds, but removed because the base was inappropriate. ("It looked like a giant buried in the ground.") Then, in 1954, area sculptor Marshall Fredericks redesigned the base, and it was rededicated "Out-of-Doors" in 1956, with the help of American citizens of German ancestry through the German American Cultural Center, Detroit, Michigan.
- Vandalized in 1967, it again was put into storage until restoration could be done on his nose.
- In 1986, the Detroit Recreation Department suggested Lincoln be relocated after restoration has been completed.
- Relocated in 1986, in a joint effort of the D.I.A., the Detroit Recreation Department, and the Civic Center Department. Nancy Shaw of the D.I.A.'s conservation staff repaired the nose prior to reinstallation in the Rose Garden.
- Rededication ceremony were held on the Rose Garden site on February 12, 1987.
- Numerous books on Borglum and his enormous undertaking at Mt. Rushmore can be found at both the Detroit Public Library and Research Library at the Detroit Institute of Arts.

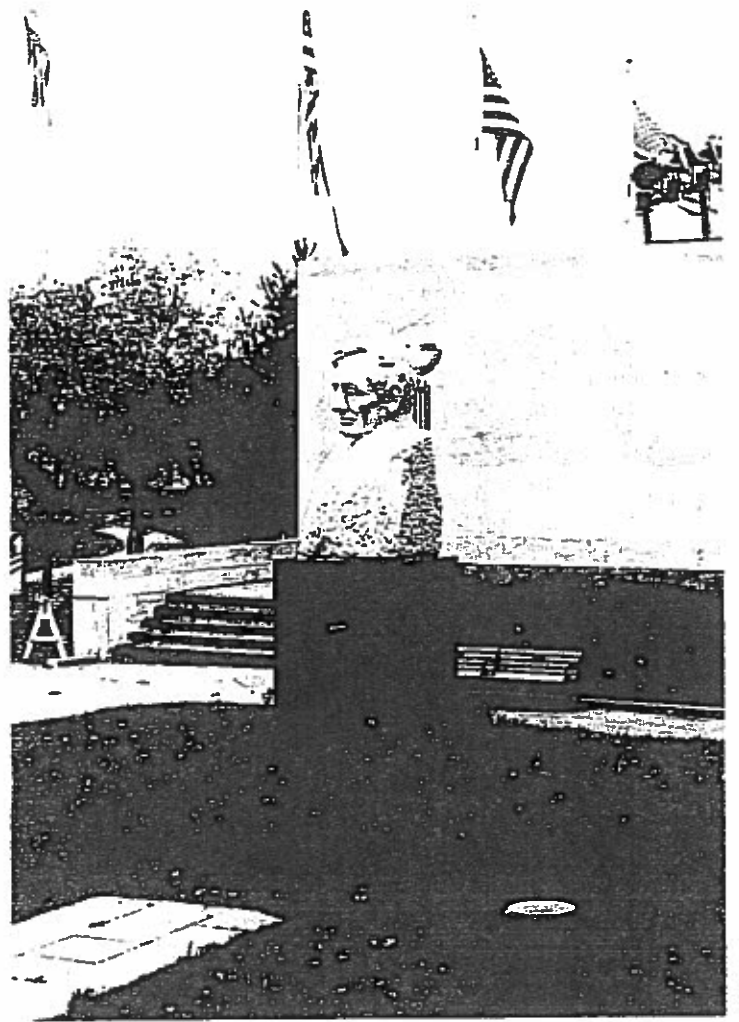
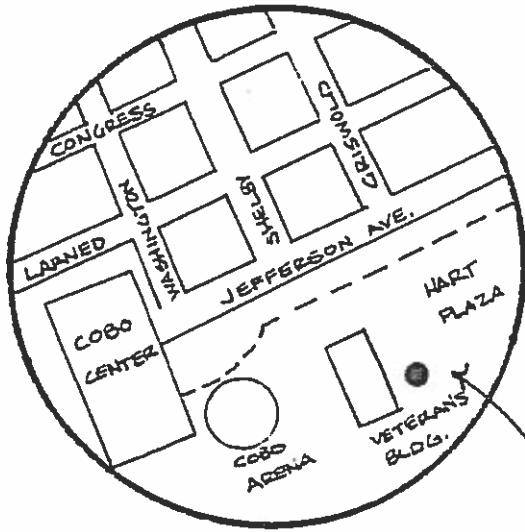

LINCOLN STATUE
(VETERANS BLDG. ROSE GARDEN)



JOE LOUIS I

Location: Woodward and Jefferson Avenues.

Sculptor: Robert Graham.

Biographical
Information: Graham is from Venice, California.

Material/
Technique: Cast and welded bronze.

Size:

Description:

Inscription:

Important
Historical
Facts:

--Cost of \$350,000 is being underwritten
by Sports Illustrated Magazine.
--Commissioned the Founders Society,
Detroit Institute of Arts.

Department
Responsible
for
Maintenance:

Condition:

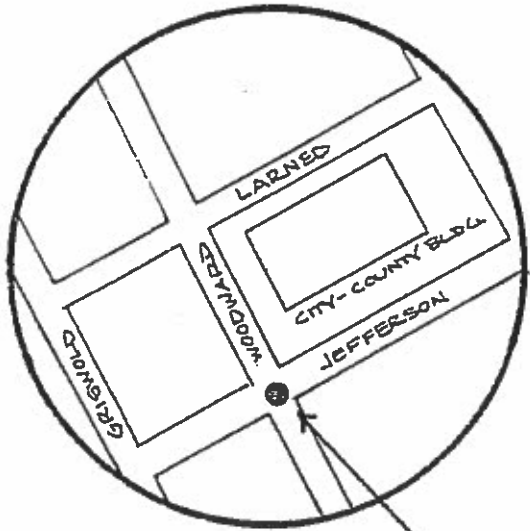
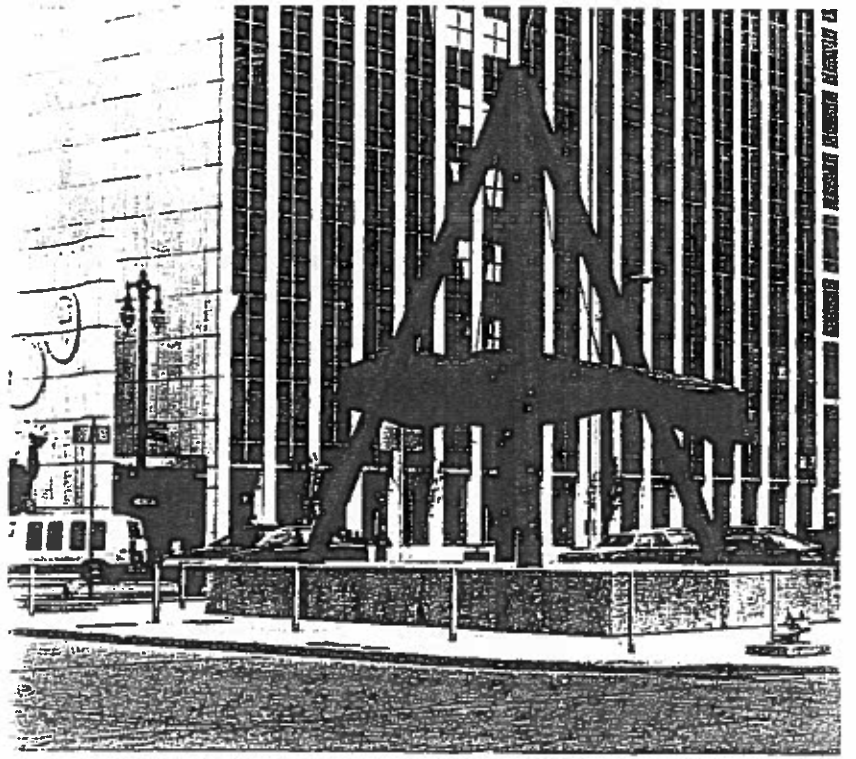

JOE LOUIS I -



JOE LOUIS II
(Work in progress as of January 15, 1987)

Location: Riverfront staircase of Joe Louis Arena,
Civic Center.

Sculptor: Edward Hamilton, Jr.

Biographical
Information: Hamilton is from Louisville, Kentucky.

Material/
Technique: Bronze.

Size: 12 ft. high.

Description: Work is in progress.

Inscription:

Important
Historical
Facts:

- Jury of five selected Hamilton out of
17 sculptors who submitted portfolios.
- Paid for by local groups.
- Joyce F. Garrett, Director of Detroit
Personnel Department, is coordinating
this project.

Department
Responsible
for
Maintenance:

Condition:

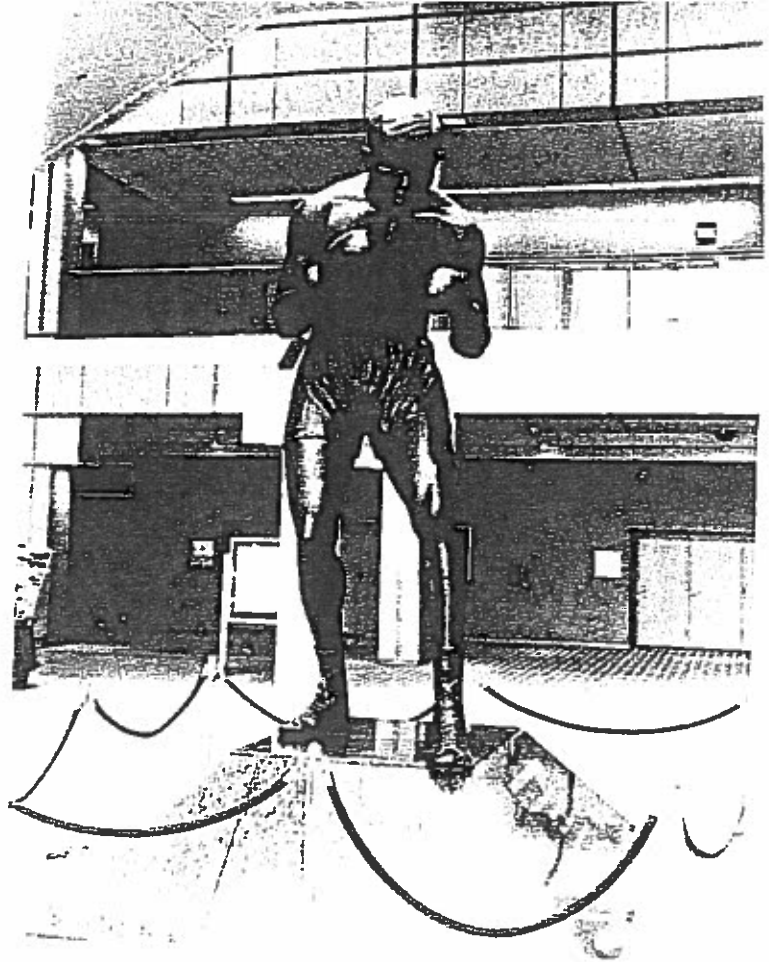
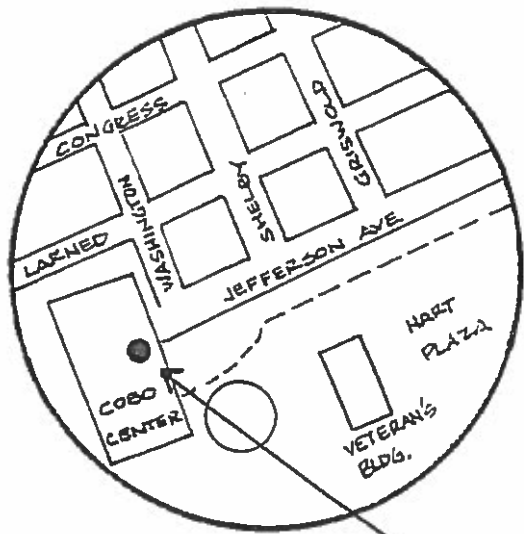

JOE LOUIS II



. JOE LOUIS III

Location:

Sculptor:

Biographical
Information:

Material/
Technique:

Size:

Description:

Inscription:

Important
Historical
Facts:

--A third Joe Louis sculpture for which
\$50,000 was donated in 1981 stands
inside the Joe Louis Arena.

Department
Responsible
for
Maintenance:

Condition:

GENERAL ALEXANDER MACOMB

Location: North side of the intersection of Washington Boulevard and Michigan Avenue.

Sculptor: Adolph Alexander Weinman.

Biographical Information: 1870-1952. Weinman came from Germany in 1880, and settled in New York City. At fourteen, Weinman became a craftsman's apprentice, and at sixteen enrolled in evening classes in drawing and modeling at the Cooper Union, N.Y.C. After transferring to the Art Students League of New York, Weinman became an apprenticed to Philip Martin, a sculptor who studied under Colin L. Warner and Daniel Chester French. Saint-Gaudens offered to make Weinman his assistant, an offer that Weinman turned down. In 1904, he received an important commission to sculpt two heroic groups for the Louisiana Purchase Exposition, St. Louis, Missouri. One group, Destiny of the Red Man, won him the prestigious silver metal. Also, occurring early in his career, he won a 1906 competition for the statue of General Macomb in Detroit. This successful work led in turn to a later Detroit commission of the statue of William C. Maybury. Weinman was also well known for his relief work and metallic art. In 1916, he designed the half dollar and dime for the mint. Other important works by Weinman include the Lincoln Memorials at Madison, Wisconsin, and Hodgenville, Kentucky, the Fountain of the Tritons on the Missouri state capitol grounds and the bronze double doors and transom at the 155th Street entrance of the Academy of Arts and Letters, New York. He was the recipient of numerous American awards and metals, and adhered to the Beaux Arts aesthetics concerning art and environment.

Materials/
Technique:

Cast bronze on a granite base.

Size:

Statue is 8 feet high, base plaza is 34 feet across base.

Description:

Macomb is portrayed in military attire with cape slightly off center, furling in the wind. Perhaps expressing the storm of battle, extreme concentration on his face is enhanced by the triangular shadow cast by his hat.

Inscription:

On the front of statue are two raised wreaths and the following: "To Major General Alexander Macomb commanding the army of the United States, hero of the Battle of Plattsburg. Monument is erected in the City of his birth by the Michigan Society of the United States, Daughters of 1812 - September 11, 1908."

Important
Historical
Facts:

- December 13, 1898, the idea to erect a Macomb Monument was born. It was suggested for Cadillac Square.
- Efforts were instigated in 1905 by the National Society of United States Daughters of 1812, State of Michigan, whose purpose was to "carry on patriotic and historical enterprises and to further educational and benevolent undertakings." The project started under the leadership of one president, Mrs. Alfred Russell, and continued with the zeal of the next president, Mrs. Bertram Whitney (who later became Mrs. Thomas Massey of New York.)
- Funding: State of Michigan, \$5,000, City of Detroit, \$2,000, the United States donated cannons to be used for metal, and the remaining \$5,000 was funded by the Daughters of 1812.

- The competition for the commission was announced January 14, 1906, in the DETROIT FREE PRESS with a February 1 deadline for sketches. Judges: Charles F. McKim, Daniel H. Burnham, and Augustus Saint-Gaudens. Some of the competitors included Edward Wagner and Carlo Romanelli of Detroit, and Mrs. John Glenny, whose mother, Mrs. Alfred Russell was the founder of the Society of Daughters of 1812 in Michigan. Each artist's model was marked with a symbol instead of the artist's name in order to insure complete fairness.
- In May, 1906, the model was displayed in the Art Museum.
- Unveiled September 11, 1908.
- It was moved back from original setting at a cost of \$3,000 in 1925.
- Macomb County desired to own the sculpture from 1972-75, but finally gave up their efforts and decided to erect their own monument.
- Sculpture has received praise and acclaim from the art world.
- History of General Macomb in brief:
 - *Born in Detroit of wealthy parentage in 1782, his parents owned much land.
 - *Moved to New York as a child.
 - *Joined the army at 16.
 - *1803, become a First Lieutenant.
 - *First graduate of West Point Military Academy.
 - *1805, promoted to captain.
 - *1814, he became Brigadier General, and on September 11, 1814, he distinguished himself at the battle of Plattsburg on Lake Champlain, New York.
 - *After the War of 1812, he returned to Detroit as Commander of the Fifth Military Department.
 - *Became General in Chief of the American Army in Washington, D.C.
 - *Died on June 25, 1842.
- Lighting for the statue was installed as part of Central District Business Foundation Project in the fall of 1986.
- More information can be obtained from the Burton Historical Section, located in the Main Branch of the Detroit Public Library.

Department
Responsible
for
Maintenance:

Detroit Building Authority.

Condition:

Concrete plaza is badly deteriorated and
needs _____ replacement.
Bronze works needs historic conserva-
tion. Conditions reported by Richard G.
Hautau, Chief of Landscape Architecture
for the Detroit Recreation Department in
8/86.

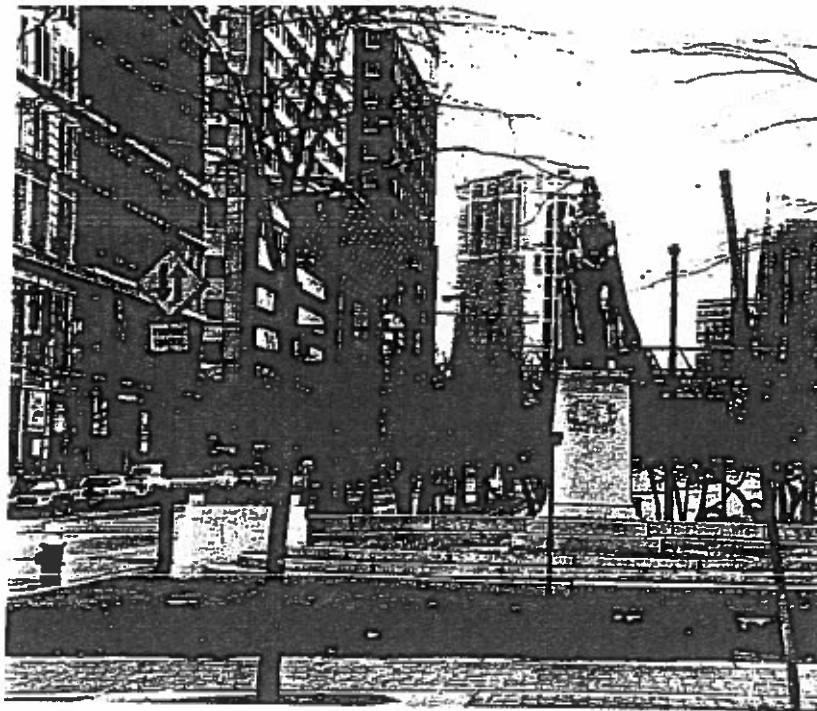
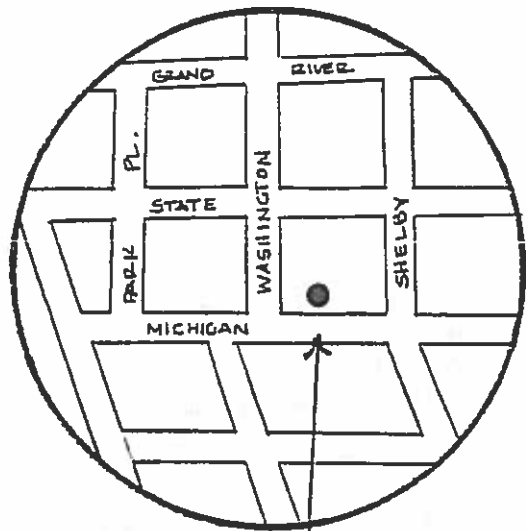

GENERAL ALEXANDER MACOMB



STEVENS T. MASON

Location: Capitol Park (site of old State Capitol Building). Griswold and State Streets.

Sculptor: Albert Weinert.

Biographical Information: Weinert was born in Leipsig, Germany, on June 13, 1863, where he also obtained his initial artistic training. He went on to study in Brussels, Belgium, and finally moved to the United States in 1886. First settling in San Francisco, he eventually ended up in New York City. Some of Weinert's important sculptural contributions include being one of the artists who worked on the Columbian Exposition Buildings in Chicago, 1893, and sculpting the decoration of the new Congressional Library Building in Washington D.C. from 1894 to 1896. He died in 1948.

Material/
Technique: Cast bronze on a granite base.

Size:

Description: The life-size bronze figure of Mason stands with left leg ahead of the right on top of a tall granite base roughly the same height as the sculpture.

Inscription:

Front

Stevens T. Mason
First Governor of Michigan

Back

The tribute of Michigan to the memory of her first Governor whose ashes lie beneath. Called to the duties of manhood while yet a boy, he so acquitted himself as to stamp his name indelibly on the history of the Commonwealth.

Important
Historical
Facts:

--Stevens T. Mason was the first governor of Michigan. Known as the "Boy Governor," he was not quite 20 when he was appointed Secretary and acting Governor of the Territory of Michigan in 1831. Mason was a strong advocate of Michigan retaining the so-called Toledo strip. His hot-headed and high-handed attitude caused President Jackson to remove him from the office of Territorial Governor. Subsequently, he was elected the State's first Governor in 1835. His position on the Toledo strip actually delayed Michigan's admittance into the union. In the end, the state of Ohio obtained Toledo. Mason was re-elected Governor in 1837, when Michigan became a state. He was also a member of the Detroit Common Council, a volunteer fireman, a member of the Detroit Young Men's Club, a devout churchman, and a property owner. Governor Mason nearly died leading Detroit through the terrible cholera epidemics of 1835 and 1837, and was alongside Father Gabriel Richard when that great servant was stricken with the disease. Mason investigated and cured the wildcat bank furor which nearly wrecked Detroit economy in that decade. On January 4, 1843, at the young age of 31, he died of scarlet fever in New York City.

- The remains of Mason had been interred in a vault for about sixty-two years when interest in them was aroused in 1905, by Lawton T. Hermans, a Mason biographer. A campaign was started to return the "Boy Governor's" remains to Michigan. Appropriately, the City Council decided to set aside the site of Michigan's first state capitol building where Mason had his headquarters for a proper burial. Finally, on June 4, 1905, with tremendous amount of fanfare Mason was brought home.
- On October 4, 1907, the City Council decided to commission a memorial for the site.
- On June 30, 1908, the sculpture of Mason was unveiled. Emily Mason, the 91 year old sister of the Governor, attended. Bronze from an old cannon donated by the War Department was used to cast the work.
- An ornamental fence which surrounded the site at one time was built in 1929.
- In December 1955, a comfort station and four new bus shelters were constructed in the area. During that time, R.G and G.R. Harris Funeral Home cared for and then reinterred the remains of the Governor.
- The semi-circular platform and balustrade which originally surrounded the pedestal have been destroyed.
- The relief of two fasces contained on the pedestal (bundles of sticks with a double-headed axe) are Roman symbols for the power of magistrates.
- More information can be obtained from the file in the Recreation Department, Planning and Grants Unit, and also at the Main Branch of the Detroit Public Library.
- The statue was lighted as part of the 1986 Central Business District Foundation Lighting Project.

Department
Responsible
for
Maintenance:

Detroit Building Authority.

Condition:

Statue in need of historic conservation
(per RGH on 8/86).

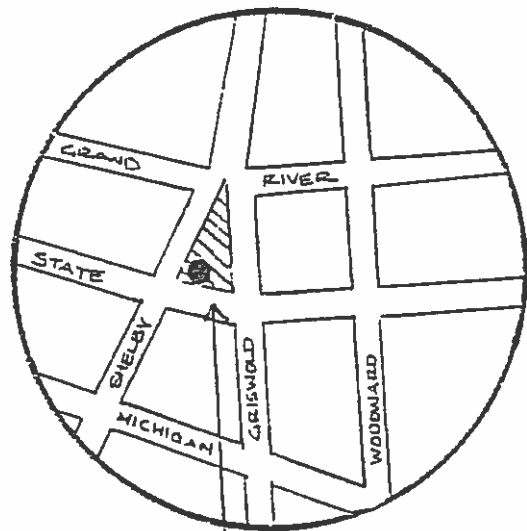

STEVEN T. MASON
(CAPITOL PARK)



WILLIAM COTTER MAYBURY

Location: Grand Circus Park, west side, Park Street and Woodward Avenue.

Sculptor: Adolph Alexander Weinman.

Biographical
Information:

1870-1952. Weinman came from Germany in 1880, and settled in New York City. At fourteen, Weinman became a craftsman's apprentice, and at sixteen enrolled in evening classes in drawing and modeling at the Cooper Union, N.Y.C. After transferring to the Art Students League of New York, Weinman became an apprenticed to Philip Martin, a sculptor who studied under Colin L. Warner and Daniel Chester French. Saint-Gaudens offered to make Weinman his assistant, an offer that Weinman turned down. In 1904, he received an important commission to sculpt two heroic groups for the Louisiana Purchase Exposition, St. Louis, Missouri. One group, Destiny of the Red Man, won him the prestigious silver metal. Also, occurring early in his career, he won a 1906 competition for the statue of General Macomb in Detroit. This successful work led in turn to a later Detroit commission of the statue of William C. Maybury. Weinman was also well known for his relief work and metallic art. In 1916, he designed the half dollar and dime for the mint. Other important works by Weinman include the Lincoln Memorials at Madison, Wisconsin, and Hodgenville, Kentucky; the Fountain of the Tridons on the Missouri state capitol grounds; and the bronze double doors and transom at the 155th Street entrance of the Academy of Arts and Letters, New York. He was the recipient of numerous American awards and metals, and adhered to the Beaux Arts aesthetics concerning art and environment.

Material/
Technique:

Cast bronze, carved marble panel, and gray granite. Cast by Roman Bronze, Inc., utilizing the lost wax process.

Size:

Description:

The pedestal is of gray granite and the seated Maybury is of dark bronze. On the marble panel behind the former mayor are carved figures typical of eloquence and charity ~~DDD~~ symbols of Maybury's reputation. At top center is carved the symbol of the city. At Maybury's feet, his name is inscribed, and at the rear of the work, his achievements are listed.

Inscription:

"William Cotter Maybury, born in Detroit, November 20, 1848, educated in her public schools and the University of Michigan. City Attorney of Detroit 1878-1880. Representative in Congress for First Michigan District 1883-1887; Mayor of Detroit 1897-1905. Died in Detroit May 6, 1909. The people of Detroit to whom this eloquent citizen and public official dedicated a life of service, charity and sympathy in loving commemoration, have erected this monument MCMXII."

Important
Historical
Facts:

--Mr. George W. Fowle was most instrumental in raising \$20,000 through popular subscription for the monument. He was a personal friend of Maybury's.
--Out of five designs submitted by Weinman, one was selected by the committee. Committee members: Alfred Lucking, David Heineman, Joseph Boyer, Charles Sawyer, Wales Martindale, Charles Freer, George Fowle, and A.H. Griffith. Efforts were initiated in 1909.

- April 2, 1912, Mr. Weinman's work was examined in New York by a special committee led by Professor A.H. Griffith of the Detroit Institute of Arts. The committee was pleased.
- Pedestal was furnished by the City of Detroit.
- Cost \$22,000.
- Unveiled on November 24, 1912.
- Temporarily relocated in 1955 during construction of the Grand Circus Park Garage.
- William Cotter Maybury was born in Detroit in 1848, graduated from the University of Michigan with a degree in Law, and was subsequently elected Detroit City Attorney from 1876-1880. He then went on to become a congressman, and finally in 1897, was elected this city's mayor, taking on the position immediately after the popular Mayor Pingree stepped down. However, he did not live in the former Mayor's shadow, but made his own contributions such as striving to make Detroit a major convention center and encouraging the construction of the Belle Isle Bridge. He died in 1909, after an unsuccessful bid for the governorship.
- Statue was restored by Venus Bronze Works, Inc. in 1987.

Department
Responsible
for
Maintenance:

Detroit Recreation Department.

Condition:

In accordance with the September, 1987, field observation made by Richard G. Hautau, Chief of Landscape Architecture of the Detroit Recreation Department, the statue needs washing and rewaxing.

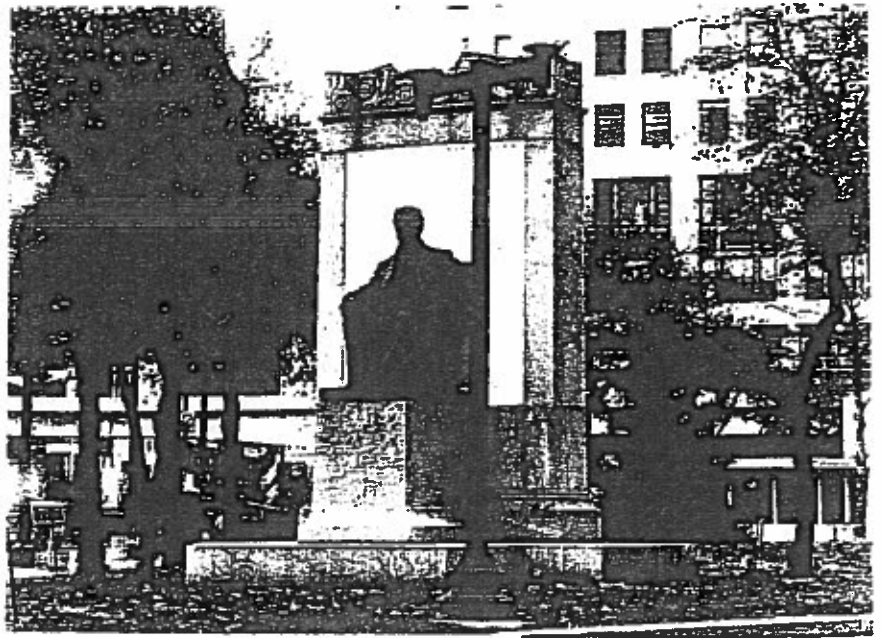
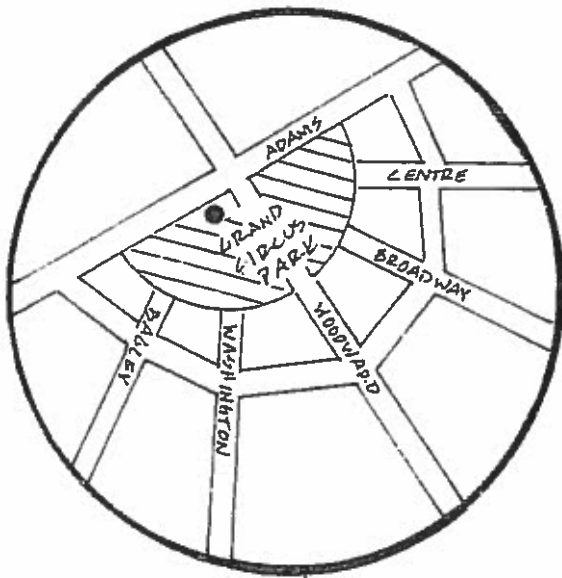

WILLIAM COTTER MAYERLY



. MONASTERY BELL

Location: Palmer Park, west of Log Cabin.

Sculptor: Unknown.

Biographical/
Information:

Material/
Technique: Wooden sign on rustic frame.

Size: 1015 lbs.

Description:

Inscription: This bell was designed and cast in the foundry of Paula Comez in France, 1793. It was taken to Mexico more than 100 years ago where it was used in a monastery to call the monks to prayer. There is a crown on top with a figure of the king on the side surrounded by other figures. Purchased by friends of Senator Palmer who gave it to the City of Detroit. Weight 1015 lbs.

Important
Historical
Facts:

Department
Responsible
for
Maintenance:

Condition:



MONESTERY BELL



HAZEN S. PINGREE MONUMENT

- Location:** Grand Circus Park, west side, corner of Woodward Avenue.
- Sculptor:** Rudolph Schwartz.
- Biographical Information:** Born in Vienna, Austria, Schwartz moved to Berlin in 1888, to study under sculptor Bruno Schmitz. He came to Indianapolis in 1897, after being sent by his teacher to execute the details of a monument. Once in the United States, he won a competition for the soldier-figures for the Indiana Soldiers Monument, which occupied him for two years. He won the competition for the Pingree sculpture in 1902.
- Bruno* ←
- Material/Technique:** Bronze, lost wax process, on a granite base. Statue constructed in pieces then loaded together. According to Richard G. Hautau, Chief of Landscape Architecture of Detroit Recreation Department, this was a poor technique.
- Size:** 10 1/2 ft., 8,000 pounds.
- Description:** The seated Pingree is shown with left foot ahead of right, right hand on thigh, left hand on arm of chair. Below his feet on the granite base is a plaque.
- Inscription:** "The citizens of Michigan erect this monument to the cherished memory of Hazen S. Pingree--a gallant soldier, an enterprising and successful citizen. Four times elected Mayor of Detroit, twice the Governor of Michigan. He was the first to warn the people of the great danger threatened by powerful private corporations and the first to

awake to the great inequalities in taxation and to initiate steps for reform. The idol of the people he died June 18, M.D.C.C.C.C.L. Age: 60 years.

I

Important
Historical
Facts:

- Competition was held in 1902. The President was Carl E. Schmidt, Secretary and Treasurer Wm. H. McGregor. 18 Models were presented. \$12,685 was collected for construction and care of the monument.
- Unveiled in 1903.
- 1904, a \$1,171.80 donation was accepted for care of the work from the Pingree Monument Association.
- Complication in casting technique--- see articles in manilla folder.
- 1955, temporarily relocated during construction of the Grand Circus Park Garage.
- 1956, a mystery time box was uncovered and opened.
- 1985, restored, and the mystery box contents were conserved and again placed in the void under this bronze statue.

Department
Responsible
for
Maintenance:

Detroit Recreation Department.

Condition:

General condition: excellent. According to Richard G. Hautau, Chief of Landscape Architecture of the Detroit Recreation Department, the statue needs washing and rewaxing.

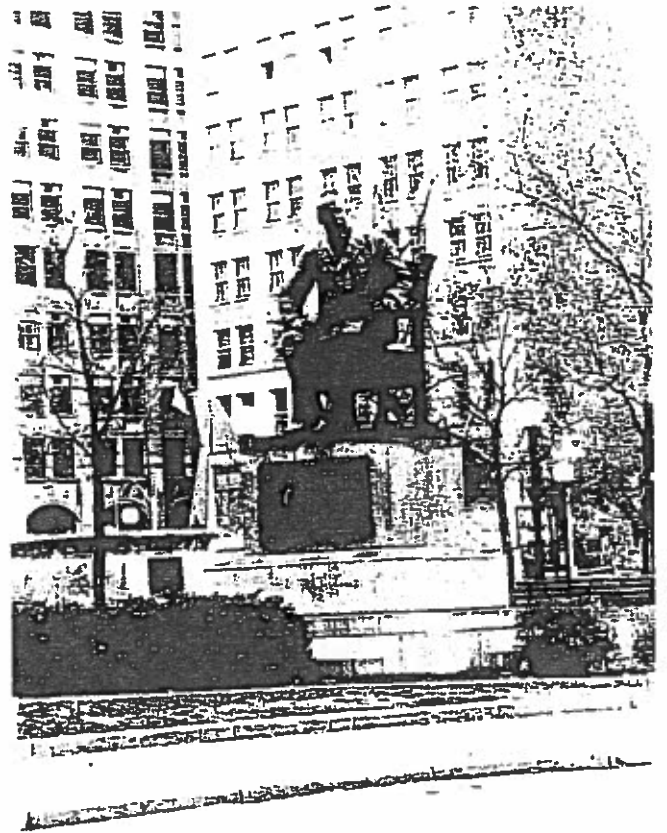
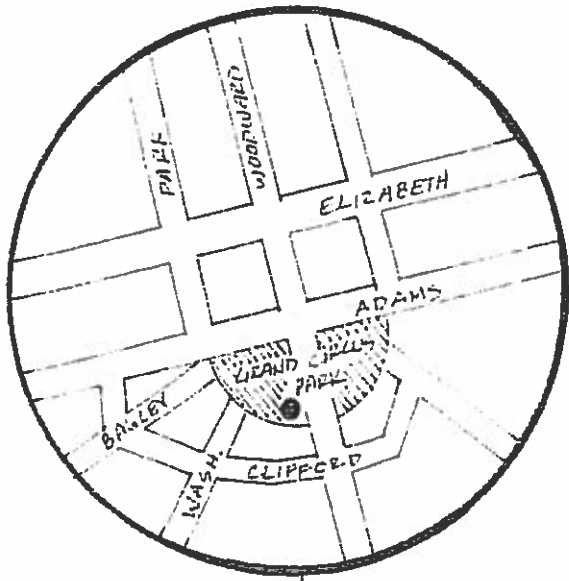

HAZEN S. PINCREE MONUMENT

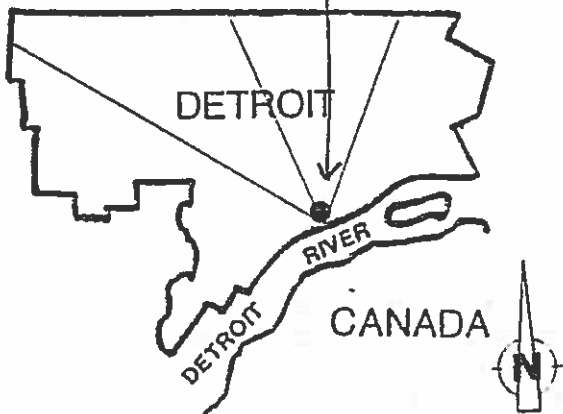

PTERODACTYL

Location: In front of the Holden Museum of Living Reptiles, Zoological Gardens, 8450 West Ten Mile Road, Royal Oak, Michigan.

Sculptor: Marshall Fredericks.

**Biographical/
Information:** Born in Illinois in 1908, Fredericks graduated from the Cleveland School of Art, and also studied in Europe. He first taught in Cleveland, Ohio, then later came to Cranbrook, Bloomfield Hills, Michigan, where he taught for nearly ten years. Other works by Fredericks owned by the City include The Spirit of Detroit, Levi L. Barbour Memorial Fountain, and the Victory Eagles and Pylons. He continues to reside and work in the area.

**Material/
Technique:** Cast bronze. The pedestal is of emerald pearl, Norwegian granite.

Size:

Description: Two Pterodactyl, connected in flight, rage over a fish downwards towards the earth.

Inscription: None.

**Important
Historical
Facts:** --The Reptile Building and the Sculpture were gifts to the Zoo from the James and Lynelle Holden Fund.
--It was unveiled May 24, 1961.

Department
Responsible
for
Maintenance:

Zoological Gardens.

Condition:

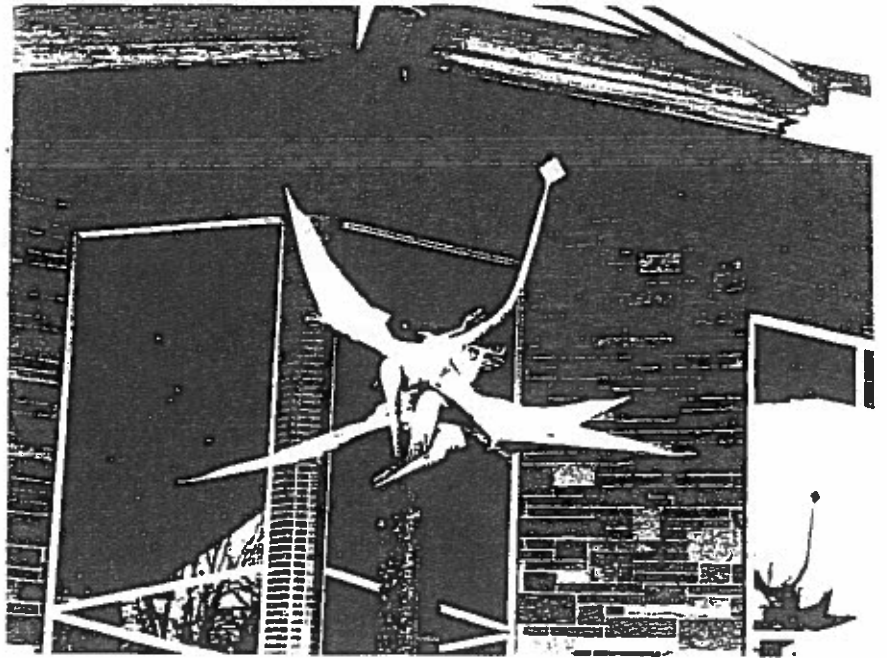
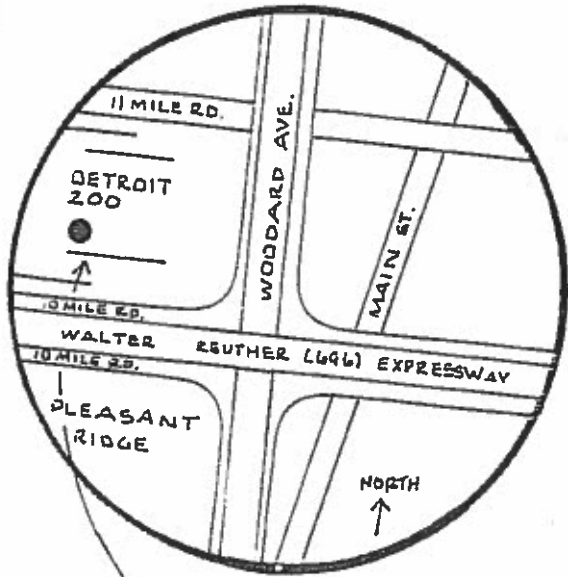

PTERODACTYL
DETROIT ZOO



GENERAL CASIMIR PULASKI

Location: Washington Boulevard and Michigan Avenue.

Sculptor: Fenenc Varga.
Designer of project: Burno Nowick, manufacturer of marble monuments, Detroit, Michigan.

Biographical Information: 1912- . Born in Budapest, Hungary, the artist resided for sometime in Detroit, but now lives in Florida. At the age of twenty he was awarded the Lord Rothermere Award at the National States Cabinets Exhibition of Art in Hungary, and was assistant professor in Budapest at the Koroly Academy under Jenő Bory. Since that time he has gone on to win international acclaim. Other works of Varga's in this area include Nikoiaj Kopernik, and Hamtramck's Pope John Paul II.

Material/
Technique: Cast bronze, wall thickness is 3/16 of an inch. The surface patina was applied by Petrucci and Patrick Murtagh. The fixative used gives the sculpture a glossy appearance. Foundry: Racine Art Foundries, Inc., Bellevue Street and Warren Avenue, Detroit, Michigan.

Size: Over 8 ft., with base it stands over 16 ft. Weight, 740 lbs.

Description: General Pulaski stiffly stands in a top coat with tails with a sword in his right hand as he gazes off into the distances.

Inscription:

Important
Historical
Facts:

- The fund raising for this project began in 1958.
- The ground breaking ceremony was held on May 20, 1965.
- In October 1966, the sculpture was put into place.
- The \$65,000 bronze sculpture was a gift to the City from combined Polish groups under the umbrella of the Central Citizens Committee. Each year in October a ceremony is held to honor this general who fought in the American Revolution.
- Brigadier General Casimer Pulaski was the eldest son of a Polish count, and before arriving in America in 1777, he had fearlessly fought in his native Poland against Russian domination. Then after having met Ambassador Benjamin Franklin in Paris, he ventured to the colonies in order to help Americans throw off the yoke of the British. He died on October 11, 1779, at the age of 31 after being shot at the siege of Savannah.
- The cost for lighting for statue was underwritten by Michigan Bell Telephone Company via a Central Business District Foundation project it sponsored in 1986.

Department
Responsible
for
Maintenance:

Detroit Building Authority.

Condition:

In 8/87, Richard G. Hautau, Chief of Landscape Architecture for the Detroit Recreation Department, made the following assessment: Statue needs historic conservation, and surrounding island's granite curb work is also in need of repairs. Both Indians on granite bollard are missing.

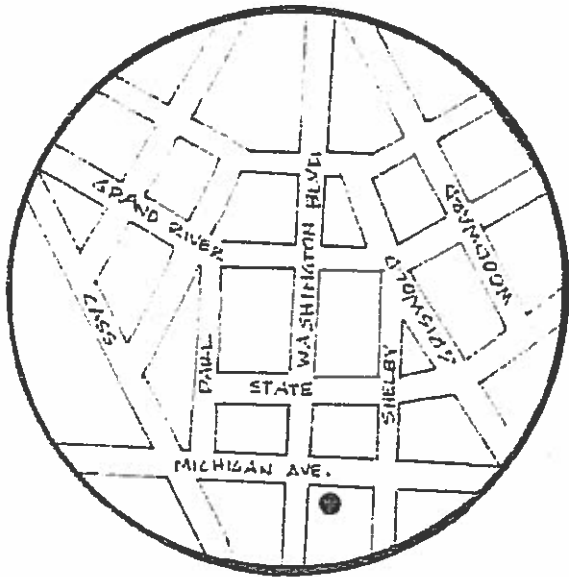

GENERAL CASIMER - PULASKI

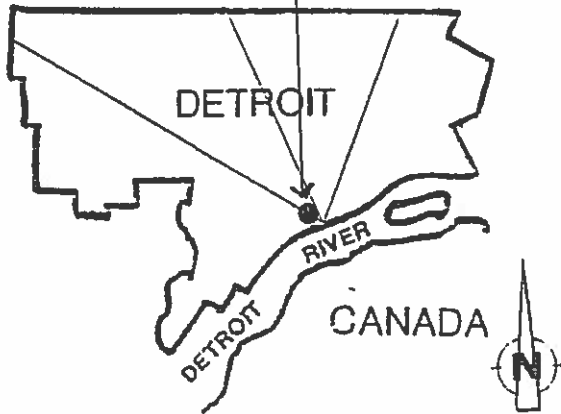

FATHER GABRIEL RICHARD MONUMENT
(STATUE)

Location: At the foot of Jefferson Avenue.

Sculptor: Leonard D. Jungwirth.

Biographical Information: Born in East Lansing, Michigan, in 1903, Jungwirth studied at University of Detroit, Wayne State University, and in Germany. He exhibited widely in the area and held positions at Wayne State University (1936-40) and at Michigan State University (1940-1963). He died in 1963.

Material/
Technique: Carved Indiana (gray) granite.

Size: 15' high. Weight: Twelve tons.

Description: Father Richard is depicted in a bold and upright fashion, holding a book to his breast. The elimination of detail, along with the geometric, slightly distorted stylization of the form reflects the block of granite from which he was carved. This was a popular aesthetic approach in the 1920s and 1930s, when direct carving of the materials allowed them to speak rather than modeling in clay or plaster for a later translation into a secondary material.

Inscription: "Father Gabriel Richard 1767-1832. Pioneer, Priest, Patriot. Founder of Churches and school, co-founder of University of Michigan, member of Congress, printer, martyr of charity, prophet and apostle of Christian civilization. He served God and Country on the Michigan frontier."

Important
Historical
Facts:

- Unveiled and dedicated on October 16, 1940.
- Gabriel Richard Monument Committee donated \$2500 for monument material costs.
- Works Progress Administration (W.P.A.) supplied the sculptor and labor. Jungwirth was supervisor of W.P.A. Arts and Crafts at the time.
- City D.P.W. installed the base, related curbs, and walks for a combined approximate cost \$1000.
- Statue relocated to Gabriel Richard Park in 1981, as part of the intersection redevelopment and removal of East Grand Boulevard tunnel to Sheridan Street. Landscape development and plantings around statue installed 1987-88 in contract with DeAngelis Landscaping.
- A young Sulpician priest, Father Gabriel Richard (1767-1832), made important contributions to the early spiritual, educational, and cultural life of Detroit. Arriving here in June 1798, he became pastor of Saint Anne's (Detroit's first parish church) in 1802. In the following years, he published Detroit's first newspaper, founded churches and schools, including co-founding the University of Michigan, and was elected to Congress. He died while ministering to the ill during a cholera epidemic.

Department
Responsible
for
Maintenance:

Detroit Recreation Department.

Condition:

According to Richard G. Hautau in 1987, it is in good condition.

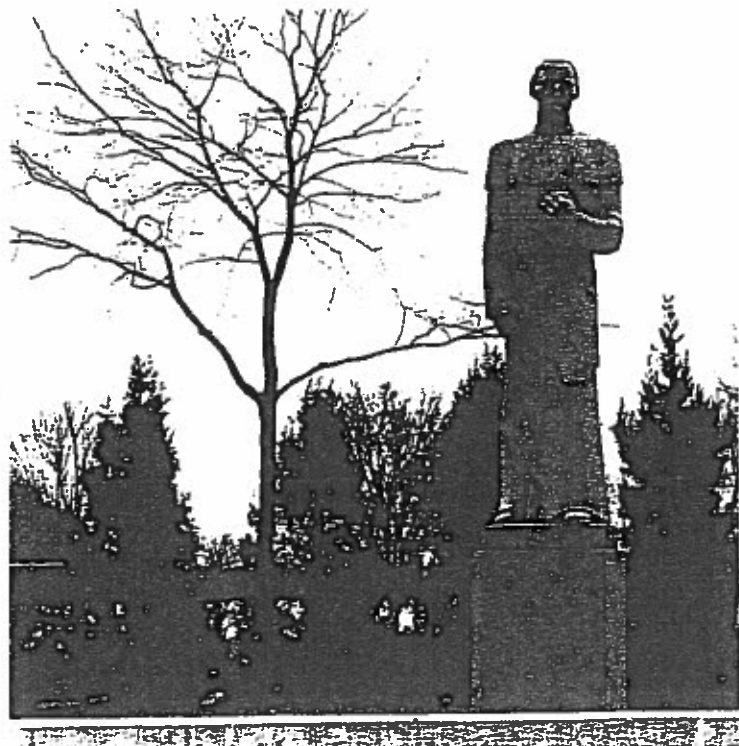

FATHER GABRIEL RICHARD MONUMENT



SOLDIERS' AND SAILORS' MONUMENT

Location: The opera intersection at Cadillac Square, Woodward Avenue and Fort Street.

Sculptor: Randolph Rogers.

Biographical/Information: 1825-1892. American.

Material/Technique: Cast bronze and ^{cap} westerly Rhode Island granite.

Size: Monument overall height is approximately 55 ft.
First tier - four eagles.
Second tier four standing 7 ft. bronze figures.
Third tier - four sitting figures.
Fourth and top tier - Figure of woman: 11 ft. height.
Total height: 56 of 60 ft. to?

Description:

Inscription: "Erected by the People of Michigan in honor of the Martyrs who fell and Heroes who fought in Defense of Liberty and Union."

Important Historical Facts:

- --July 20, 1861, a public meeting was held and a resolution adopted to erect a "to our heroic dead" monument.
- July 1865, a meeting was held and a committee appointed. The movement was state-wide and the association was organized with 111 directors.

- August 31, 1865, the first public meeting was held at Young Men's Hall and donations of \$9,500 were received.
- February 1867, the DETROIT FREE PRESS announced that the Michigan Soldiers and Sailors Monument Association would receive suggested designs from sculptors, submitted before June 15, 1867.
- June 28, 1867, the design of Randolph Rogers was accepted. For a list of the other eighteen sculptors who submitted designs, see the DETROIT DAILY POST, April 9, 1872.
- July 4, 1867, the cornerstone for the document was laid in East Grand Circus Park. Within the cornerstone was placed a metal coffer with historical papers inside. The Detroit Common Council refused the request to occupy the first choices of Campus Martius or the intersection of Jefferson and Woodward Avenues. However, because of public protest, the cornerstone was finally moved to Campus Martius with documents still intact.
- April 9, 1872, with a tremendous amount of fanfare and celebration, the monument was unveiled. The total cost of \$65,000 had been raised through subscriptions---school children, Masonic, Oddfellows, Good Templers, and Aux Ladies Monument Associations.
- 1883, a public act of Michigan appropriated \$100 per year for the care and preservation of the monument. This amount was reduced to \$85 in 1932, and funds finally withdrawn in 1958.
- 1893, in order to allow those who wished to decorate the monument free access, the fence surrounding the monument was removed.
- Moving the monument was discussed by the City in 1901, 1929, and 1936, but no action was actually ever taken. The foundation of the monument was repaired in 1941.

--Condition: restoration repair work completed for \$100,000 with contract made possible by the Detroit Renaissance. Calculus Construction, general contractor. Venus Bronze Works, Inc., historic conservator. Completed in summer, 1986

Department
Responsible
for
Maintenance:

Detroit Recreation Department.

Condition:

Washing and rewaxing needed as of 9-87.

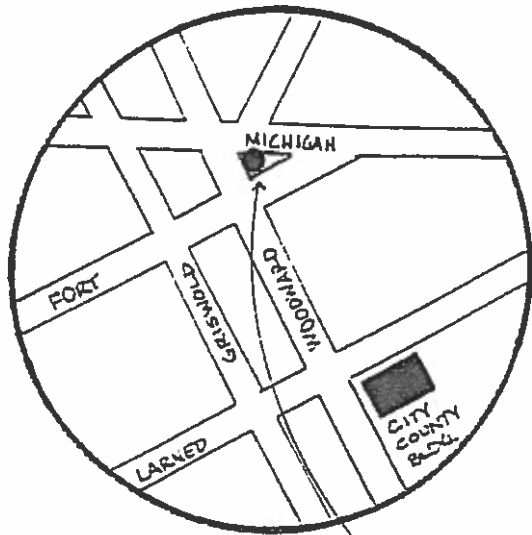

SOLDIERS! SAILORS



THE SPIRIT OF DETROIT

- Location:** City-County Building, Woodward and Jefferson Avenues.
- Sculptor:** Marshall Fredericks.
- Biographical/
Information:** Born in Illinois in 1908, Fredericks graduated from the Cleveland School of Art, and also studied in Europe. He first taught in Cleveland, Ohio, then later came to Cranbrook, Bloomfield Hills, Michigan, where he taught for nearly ten years. He studied under Carl Milles. Other works by Fredericks owned by the City include: Levi L. Barbour Memorial Fountain, Pterodactyl and the Victory Eagles and Pylons. He continues to reside and work in the area.
- Material/
Technique:** Cast bronze with green patina, the family group and symbol of God are gilded bronze. The wall is made of Vermont marble.
- Size:** The bronze figure is 16 ft. and weighs 9 tons. It is set against a 36 x 45 ft. wall with the two official seals approximately 10 1/2 ft. in diameter.
- Description:** The huge seated figure representing the universal spirit of man holds in his left hand a sphere with emanating rays, representing God, and in his right hand a family group symbolic of all human relationships. Two seals are carved into the wall behind, symbolizing city and county.

Inscription: "Through the spirit of man is manifested in the family, the noblest human relationship."

(On the wall)

"Now the Lord is that Spirit and where the Spirit of the Lord is, there is liberty." 2 Corinthians 3:17

Important
Historical
Facts:

--Cast in Norway.
--Cost \$40,000.
--Commissioned in 1955.
--Dedicated in 1958.

Department
Responsible
for
Maintenance:

Detroit Jr Wayne Bor Home Authority
Detroit Recreation Department.

Condition:

Note: Marshall Fredericks does not generally support restoration efforts of

patinas, but believes works should honestly wear the effects of time.

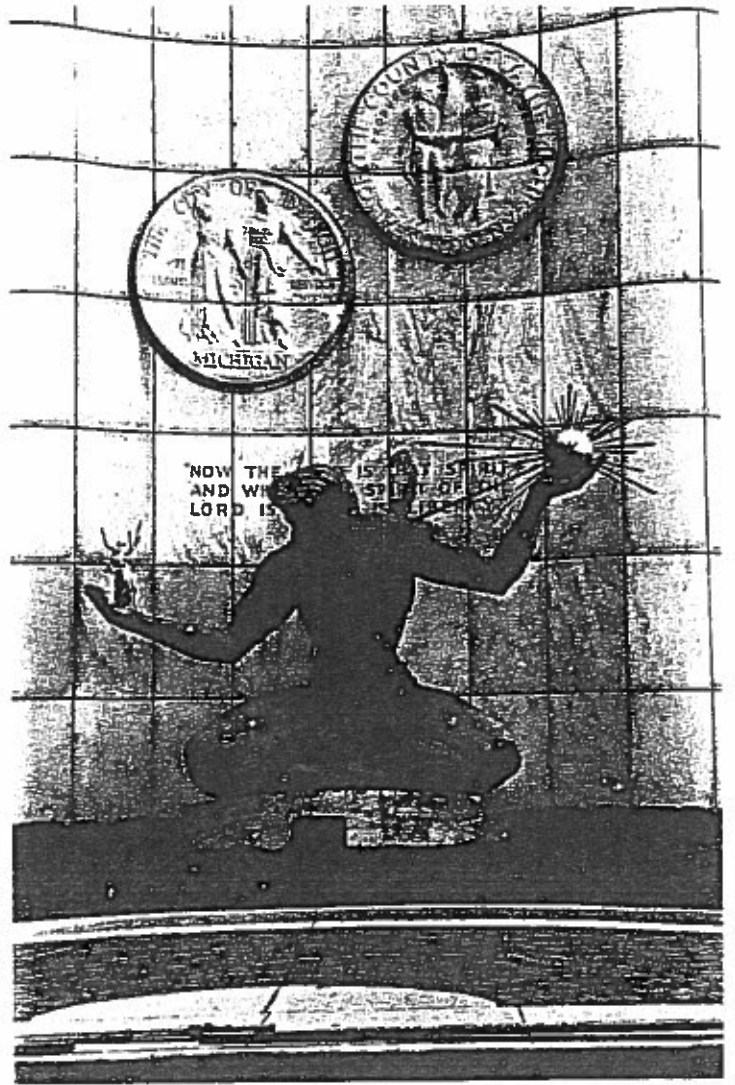
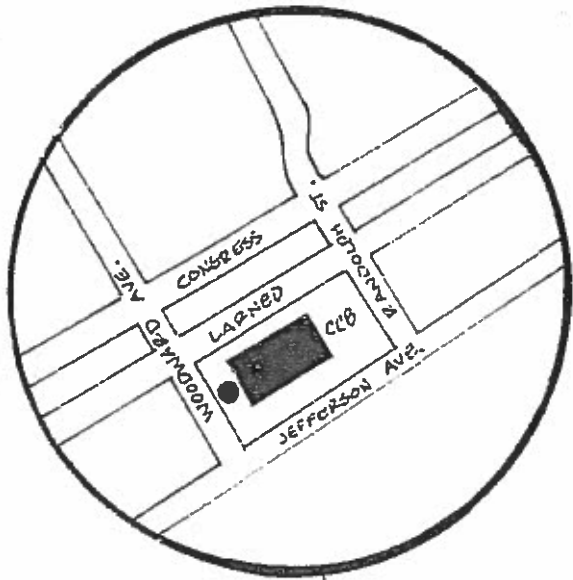

SPIRIT OF DETROIT

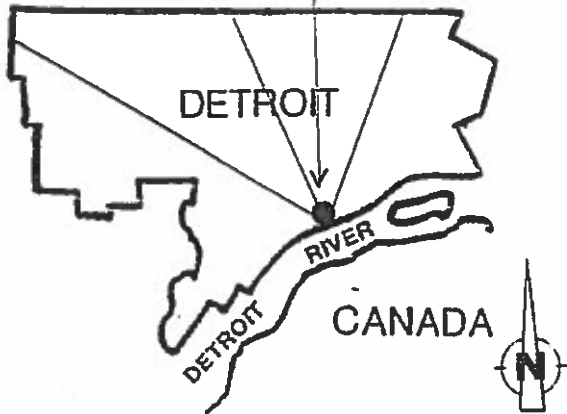

SPIRIT OF TRANSPORTATION

Location: Storage, 1985. To be placed inside Cobo Hall after completion of the expansion project.

Sculptor: Carl Milles.

**Biographical/
Information:** Born in Sweden, in 1885. Milles also died in Sweden. However, from 1931 until 1951, Milles was resident sculptor and head of the department of sculpture at Cranbrook Academy of Art, Bloomfield Hills, Michigan. His accomplishments and awards are numerous.

**Material/
Technique:** Cast bronze. Cast by Burno Bearzi in Florence, Italy.

Size: 9 feet. Indian on 20 foot pedestal.

Description: Figure of an Indian carries a canoe over his shoulders atop a fountain pedestal which sprays water beneath his feet. He represents the spirit of transportation linking the city with its early accomplishments.

Inscription: None.

**Important
Historical
Facts:** --Mrs. Alvin McCauley bought the sculpture as a memorial to her late husband at a cost of \$30,000 and presented it to the City of Detroit through the Capital Gifts Committee.

--Alvin McCauley, builder of the former Packard Motor Car Company, died in 1952. Work on the statue was done by Dr. Milles in Rome where he lived in his later years. The statue was shipped to this country and stored at the Detroit Institute of Arts until Cobo Hall and the site for the fountain were made ready.

--Before the sculpture went on display, Council Eugene VanAntwerp protested its nudity, and demanded a lion cloth be provided. loin

--In 1960, Bertold Schiwets, a sculptor who was teaching at Cranbrook at the time, sculpted a lion cloth. He hoped the screws which attached the lion cloth would rust and cause it to fall off. loin

--It was placed in front of Cobo Hall in 1960.

--A "twin" of the Detroit sculpture stands completely nude in Lidings, Sweden.

--Until 1971, the lion cloth became an issue. However, because of Indian protest, the cloth still remains attached.

Department
Responsible
for
Maintenance:

Detroit Recreation Department.

Condition:

In the spring of 1985, restoration work was started by George Gikas of Venus Bronze Works, Inc.

GOMIDAS VARTABED

Location: East Jefferson Avenue near Woodward Avenue.

Sculptor: Arto Chakmakian.

Biographical/
Information: Artist is an American from Montreal, Canada.

Material/
Technique: Cast bronze.

Size: 16 ft. tall.

Description: The mournful, austere, Vartabed clutches his straight left arm with his right arm bent at a 90 degree angle. The vertical, linear folds of his robe and gently rippling collar set off an almost emaciated silhouette. His furrowed brow and exaggerated hands accentuate a deep silent, emotion.

Important
Historical
Facts:

- Project was initiated by Moe Assarion, who had survived the Armenian Holocaust of 1915-20, and prominent Armenian businessman Alex Monogian. The Armenian church raised the \$60,000 necessary and the City offered the spot where the statue now stands.
- It was erected in memory of the 1.5 million Armenians who died at the hands of the Turks prior to World War I.
- Gomidas Vartabed was a composer of religious and Armenian folk music, but also a man of peace and love, and an intellectual leader of his community.
- Unveiled June 21, 1981.

Department
Responsible
for
Maintenance:

Detroit Recreation Department.

Condition:

Good.

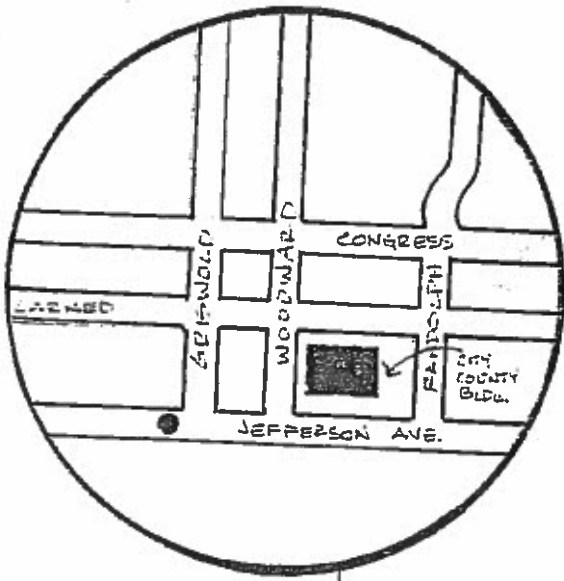

GOMIDAS VARTABED

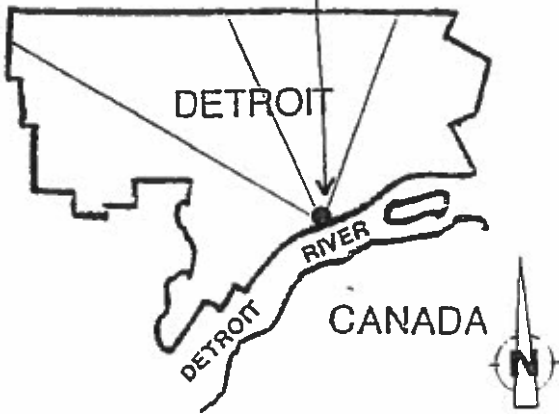

VICTORY AND PROGRESS

- Location:** Roof of the old County Building, Randolph Street side, and four corners around main tower.
- Sculptor:** John Massey Rhind.
- Biographical/
Information:** 1860-1936. A native of Scotland, his father and grandfather were sculptors before him. He arrived in America in 1889, and was soon successful with the decoration of the Memorial Chapel of the General Theological Seminary in New York. He worked on the Victory and Progress group in 1903.
- Material/
Technique:** Stamped bronze. Bronze work by Mullins Manufacturing of Salem, Ohio.
- Size:**
- Description:** Representing victory and progress, each of these animated groups consists of a draped female figure standing in a classical chariot drawn by three rearing horses. Each team of horses is led by two partially clad, youthful males. According to John Scott, the architect of the County Building, there were no specifications given except the ideas of victory and progress. The result was the kind of statuary put on many public buildings at his time inspired by the old Roman idea. He said that he made the sketches for it, but the sculptor was J.M Rhind.
- Four allegorical female figures representing law, commerce, agriculture, and mechanics surround the main tower. The figure depicting law has the fasces and a bundle of rods with an ax blade the badge of authority for magistrates in

Department
Responsible
for
Maintenance:

Condition:

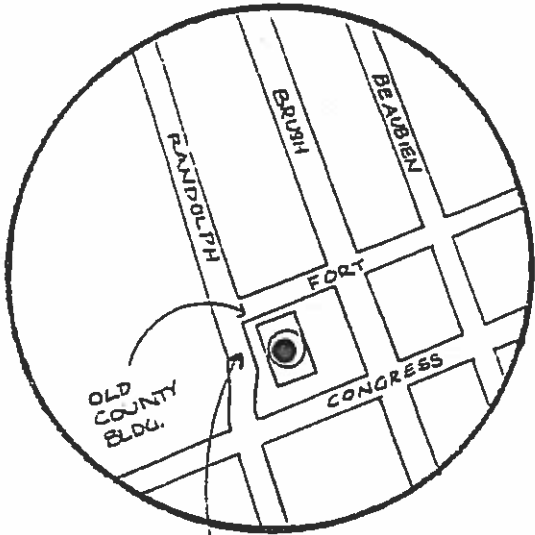

VICTORY AND PROGRESS



VICTORY EAGLE AND PYLONS

Location: Veterans Memorial Building, 151 West Jefferson Avenue.

Sculptor: Marshall Fredericks.

**Biographical/
Information:** 1908- . Marshall Fredericks is a prominent area sculptor and art patron.

**Material/
Technique:** Carved marble. Ten blocks comprise the Victory Eagle. Together the blocks weigh 34 tons. A specially designed steel supporting structure had to be put into place in order to fit the work into the wall and to carry the weight. The blocks were quarried in the interior quarries at Danby, Vermont.

Size: The Eagle is approximately 30 feet tall.

Description: A powerful, simplified eagle in the shape of a "V" clutches an olive branch. The dramatic work is a relief, playing an integral role in the expansive marble wall. Below is an inscription and part of the great seal of the U.S. in bronze. Seven pylons arranged along the walkway to the west of the eagle refer symbolically to various historical events significant to war veterans in Detroit.

Meaning of the seven pylons: The seven pylons of the Veterans' Memorial Building represent the following events in the nations history:

- (1) Founding of Detroit - Early French Explorer, Cadillac and Father Richard.

- (2) Indian Wars. Treaty with Chief Pontiac.
- (3) Battles of the Great Lakes, War of 1812 - Perry's Victory.
- (4) Civil War, Abraham Lincoln with portraits of General Lee and General Grant. Lincoln's vision of Peace and Unity between the States.
- (5) Spanish American War, Roosevelt Rough Riders, Surrender of Spanish troops, Naval Victories suggested by Commodore George Dewey Medal awarded the Officers and men in Phillipine campaign.
- (6) World War I, Symbolic Shields of the "Big Four" Nations with President Wilson's statement: "To make the world safe for Democracy." Figures of a mother and children, the family, safe and protected beneath the Stars and Stripes.
- (7) World War II. The Peach Pylon, a purely symbolic and spiritual conception representing the hand of God holding the laurel branch representing valor and honor, superimposed upon the palm branch of Peace. Below a quotation from the Star Spangled Banner, "Blest with Victory and peace in God is our trust," and the Eagle of the Great Seal of the United States of America.

This pylon is dedicated to the thought that "In the hearts of all mankind is the Eternal Hope for a Universal Peace."

Inscription:

"In honored memory of those who gave their lives for their country."

Important
Historical
Facts:

--The relief was a part of the earliest plans for the Veterans Memorial Building by architects Harley, Ellington and Day (now Harley, Ellington, Pierce, Yee Associates).
--Completed in 1950.

Department
Responsible
for
Maintenance:

Civic Center Department.

Condition:

As of 6-87, good condition.

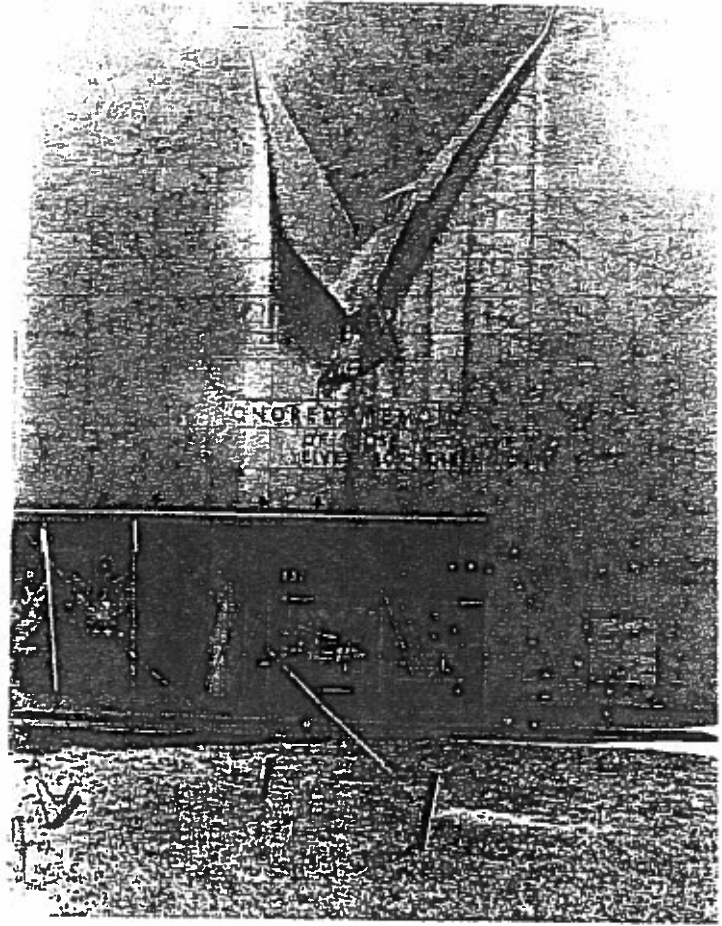
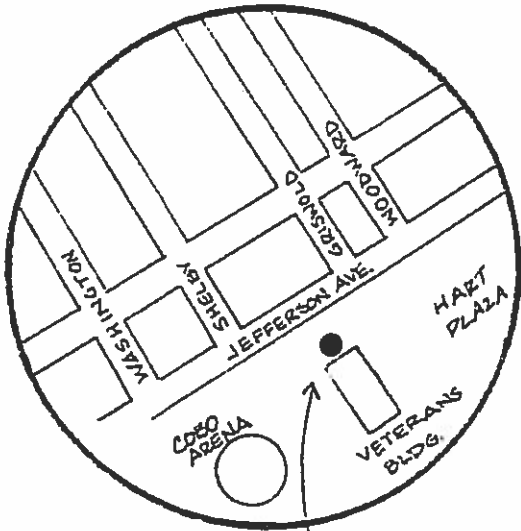

VICTORY EAGLE & PYLONS



GENERAL GEORGE WASHINGTON

Location: Between north wall of Mariners' Church and the sidewalk of Jefferson Avenue near the southwest corner of Jefferson Avenue and Randolph Street intersection.

Sculptor: Donald DeLue.

Biographical Information: 1987. DeLue, a Bostonian at birth, studied at the Boston Museum of Fine Arts School. Known for working in both bronze and marble, he has been honored consistently throughout his long artistic career.

Size: Approximately 8 ft. Weight, 1,800 lbs.

Description: Washington's bent left arm holds a three-cornered hat while his right arm grabs a gavel which rests upon a pedestal. His hair is pulled back at the nape of his neck and his expression is unsmiling, even dour.

Inscription:

Important Historical Facts:

--1966, Washington was chosen by the Michigan Masons to exemplify 10 centuries of free Masonry because he was master of the Mason Lodge in Alexandria, Virginia, when elected President of the United States of America.

--April 26, 1966, the Masons first wanted to have Washington rest on Washington Boulevard at Clifford; however, this site was rejected for aesthetic reasons. Mariners Church was suggested because:

1. It was the site of the first permanent meeting place for the Masonic Order in Michigan, organized in 1764;
2. The location provides good exposure;
3. The gothic architecture of the church blends well with the style of the sculpture; and
4. The Mason's are dedicated to both religions and civic issues. Thus, the location near the City's Civic Center and alongside a church is symbolically appropriate.

--May 22, 1966, more than 5,000 Masons paraded on the occasion of their 1,000th Anniversary. Percy H. Williams, Most Worshipful Grandmaster of Michigan, presented the statue to the City; Mayor Cavanaugh accepted.

Department
Responsible
for
Maintenance:

Detroit Recreation Department.

Condition:

On 9-87 Richard G. Hautau, Chief of Landscape Architecture for the Detroit Recreation Department, advised that the bronze material needs historic conservation work with treatment to be determined at future date.

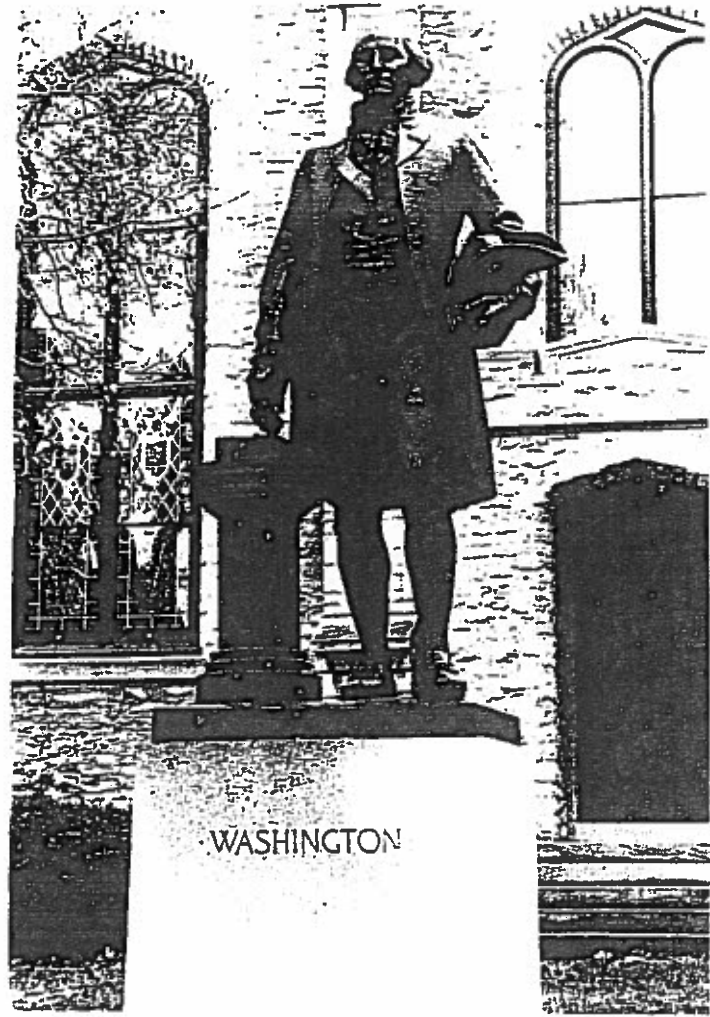
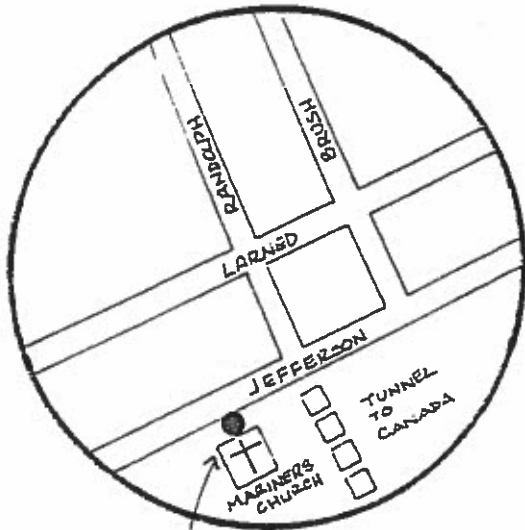

GENERAL GEORGE WASHINGTON
MARINERS CHURCH

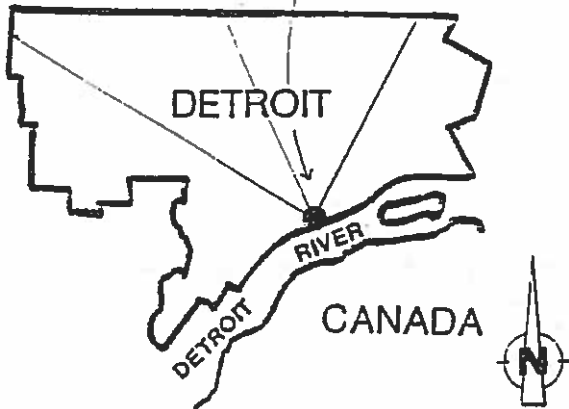

BELLE ISLE SCULPTURES

DANTE ALIGHIERI

Location: Belle Isle Park, Central and Vista Avenues.

Sculptor: Raffaello Romanelli.

Biographical/
Information: 1856-1928. Italian.

Material/
Technique: Carved marble.

Size:

Description: The stern, deeply chiseled features of the famous poet stare straight ahead in an expression of fierce determination. The bust is clothed in a high-necked cloak and hood, and a laurel wreath---the traditional symbol of honor---adorns Dante's head. The bust rests on both a simple pedestal and a tall decorative base.

Inscription:

Important
Historical
Facts: --In 1921, in honor of the 600th Anniversary of Dante's death, the Italian community in Detroit commissioned a bust by sculptor Carlo Rivalta, whose father had executed Detroit's Christopher Columbus bust in 1910. However, due to a disagreement between the monument committee and the general committee, this bust was rejected by the library where it was supposed to rest, and was later donated to the Detroit Institute of Arts. A second bust was ordered to be made by the renowned Italian sculptor Raffaello Romanelli.

- The library refused the second bust because it was larger than agreed upon, therefore, it lay in storage for a number of years. Luckily, the City Plan Commission accepted the work in October 1925, and a pedestal was ordered from Italy. Yet due to lack of funds, the work was not erected until July, 1927.
- Dante was erected in the name of all Italo-Americans of Detroit.
- Vincenzo Guiliano, editor of La Tribuna del Popolo, was instrumental in obtaining this work. He was also involved in the events surrounding the Christopher Columbus bust in 1910.
- Lost: \$2,500. Foundation work donated by Leto Brothers, Italian Contractors.

Department
Responsible
for
Maintenance:

Detroit Recreation Department.

Condition:

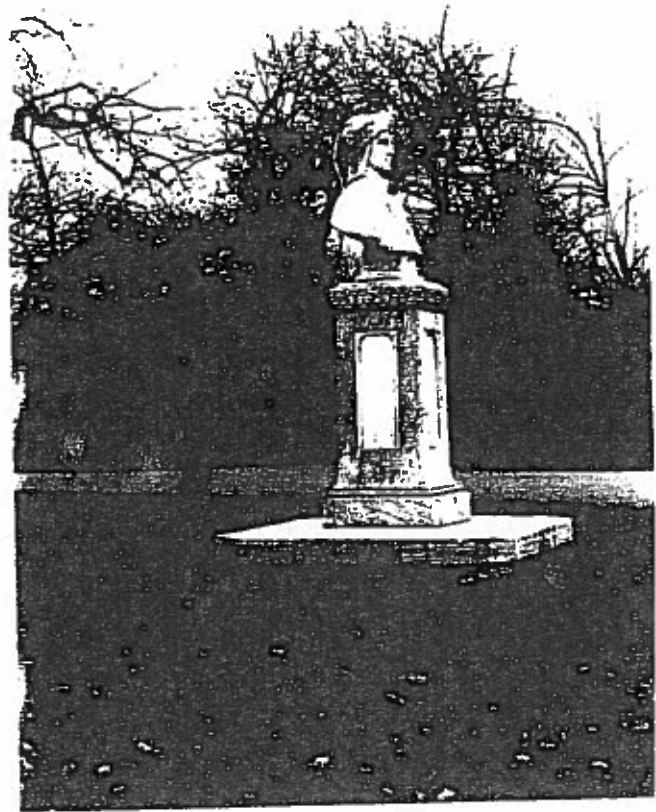
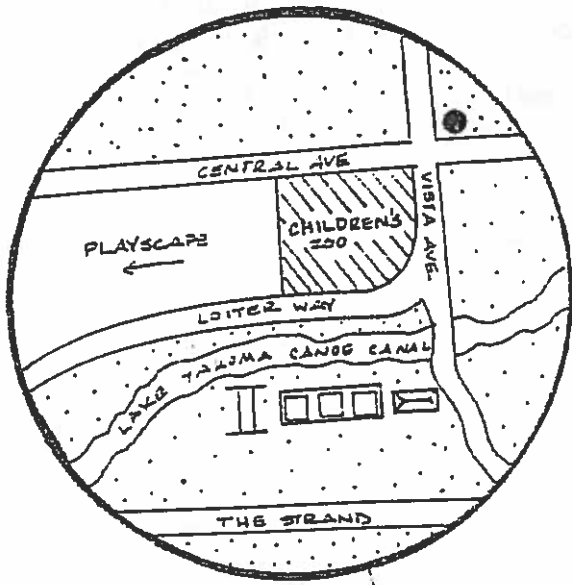

DANTE ALIGHIERI

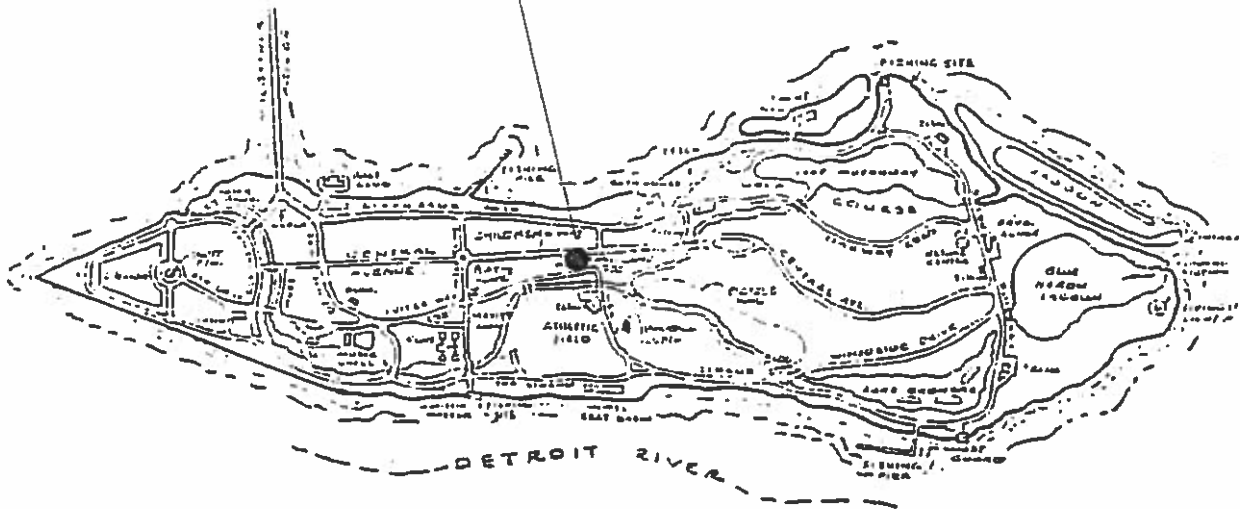

BELLE ISLE PARK

LEVI L. BARBOUR MEMORIAL FOUNTAIN

- Location:** Center of Rose Garden on Belle Isle Park.
- Sculptor:** Marshall Fredericks.
- Biographical/
Information:** Born in Illinois in 1908, Fredericks graduated from the Cleveland School of Art, and also studied in Europe. He first taught in Cleveland, Ohio, then later came to Cranbrook, Bloomfield Hills, Michigan, where he taught for nearly ten years. Other works by Fredericks owned by the City include The Spirit of Detroit, Pterodactyl, and the Victory Eagles and Pylons. He continues to reside and work in the area.
- Material/
Technique:** Melen black granite. Cast Verde antique green bronze central figure.
- Size:** The fountain is 25 feet in diameter at the widest point.
- Description:** Wounded or leaping gazelle is the main figure and the four smaller figures at the base are all native to Belle Isle, which are a rabbit, a hawk, an otter and a grouse. Water sprays in fine streams from the outside edge of the smaller basin into the large basin.
- Inscription:** "A continual hint to my fellow citizens - to devote themselves - to benefit and pleasure of the public."

Important
Historical
Facts:

- 9-16-1926 A \$20,000 check from Barbour estate was deposited with City Treasurer and credited to account of Levi L. Barbour Memorial Fund. J.C.C. 2835. Barbour lived from August 14, 1840 until July 10, 1925. Barbour was a wealthy, liberal, civic-minded lawyer who fought hard to purchase Belle Isle for public use.
- 11-21-1934 Corporation Consul instructed City Plan Commission, Arts Commission, and Parks and Boulevards, to select a site for the Levi Barbour Memorial and to present plans and designs for said memorial. J.C.C. 2135.
- 9-17-1935 C.C. approved proposal of Levi Barbour Memorial Committee to proceed according to the accepted plans for securing designs and models for the memorial. J.C.C. 1765.
- 1-9-1936 Jury of three, consisting of Adolph A. Weinman, sculptor, New York City, Meyric R. Rogers, St. Louis Art Museum Director, and John A. Holabird, Architect, Chicago, awarded first prize to Marshall Fredericks.
- 5-13-1936 Contract between Marshall Fredericks and City of Detroit for \$20,000 approved and confirmed. J.C.C. 1193.
- 11-25-1936 Completed and tested.
- 6-25-1937 Memorial unveiled and dedicated (Total Cost: \$26,000)

Department
Responsible
for
Maintenance:

Detroit Recreation Department.

Condition:

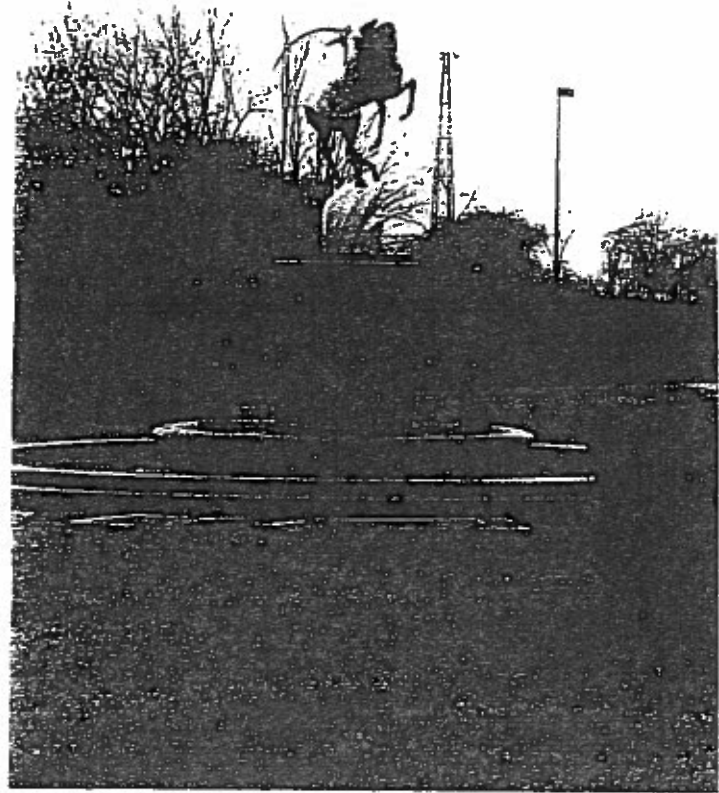
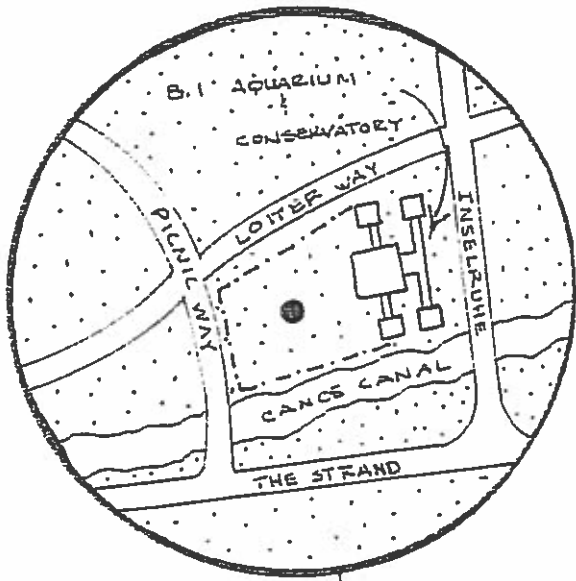

LEVI L. BARBOUR MEMORIAL FOUNTAIN
ROSE GARDEN

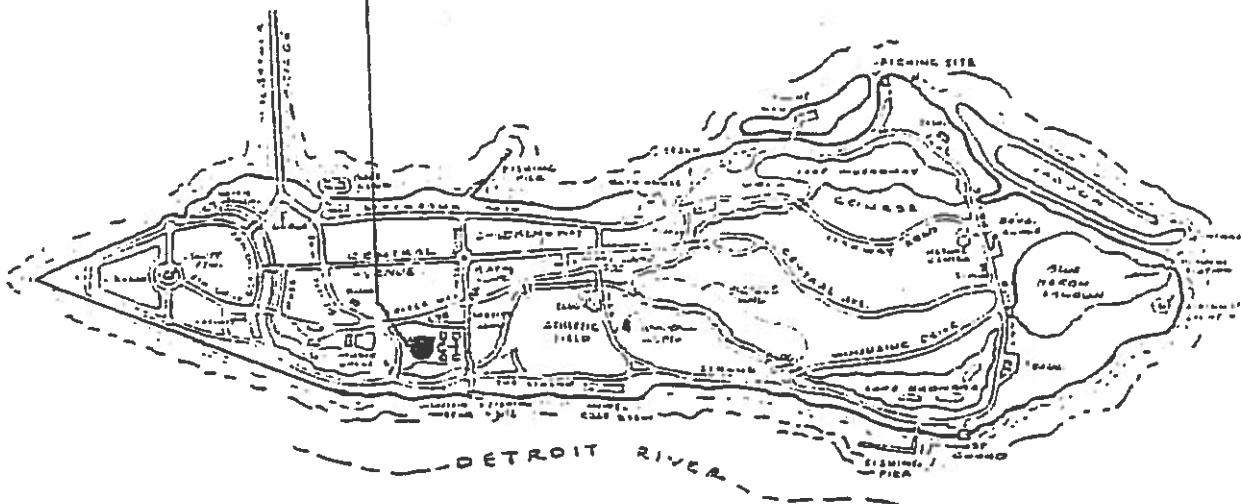

BELLE ISLE PARK

JAMES J. BRADY MEMORIAL MONUMENT

Location: Belle Isle Park. South side of Central Avenue between Williams and Scott Memorials.

Sculptor: Samuel A Cashwan, sculptor, Fred C. O'Dell, architect.

Biographical Information: Cashwan was born in Cherkassi, Russia, in 1900, and studied art in New York and Paris. Having first taught architectural sculpture at the University of Michigan in 1927, he joined the faculty of the Detroit Society of Arts and Crafts as Head of the Sculpture Department. He was also the WPA-Federal Art Project Supervisor in sculpture in Michigan during the depression. In 1942, he became a designer at General Motors Corporation. Having received many commissions, examples of his work are numerous in this area. The Frank G. McInnis Memorial Fountain and the Rev. Samuel Francis Smith Flagpole by Cashwan are also owned by the City of Detroit.

Fred C. O'Dell was an architect who taught at the University of Michigan Architecture School.

Material/Technique: Bronze and Vermont granite.

Size: 17 ft. x 15 ft. x 7 ft.

Description: Life-size figure of James Brady shields a frail, barefoot girl under his overcoat. On the base are two bronze plaques.

Inscription:

Back

"This monument was sponsored by the Old Newsboys' Goodfellow Fund of Detroit and paid for by popular subscription.

Officers

Ernest P. Lajoie, President
Walter I. Mackenzie, 1st Vice-President
Herman Schmier, 2nd Vice-President
Nathan Samuels, Secretary
Herman Schmeman, Treasurer

Board of Directors

David A. Brown
Herman Leibermann
Robert Y. Ogg
George T. Hunter
A. Peter Kennedy
James W. Bishop
William A. Parrish
William Gutman
Joseph W. Brady
Fred T. Grenell

The cooperation of the members of the Detroit Fire Department is gratefully acknowledged. Dedicated June 23rd A.D. 1928."

FRONT

Directly under the statue - center
"JAMES J. BRADY
Founder

Old Newsboys Good Fellow Fund"

Right front Plate

"Because he loved the children of the poor and devoted his life to good works his friends have caused this monument to be created and erected."

Left plate front

"The Good Fellow Guide"

Picture of a man with basket and several bundles in left arm, walking. Right hand in the hand of small newsboy with paper in his arm leading by hand.) In-
scription: "As our tribute to the spirit of charity this monument is affectionately dedicated to the memory of the late James J. Brady, founder of the Old Newsboys Good Fellow Fund of Detroit."

Important
Historical
Facts:

- Erection of this monument was approved by the City Council on February 2, 1928.
- On June 23, 1928, it was unveiled by the Friends and Old Newsboys Goodfellow Fund.
- Total cost was \$7,000.
- The Old Newsboys Goodfellows replaced two missing plaques in 1948.
- The Old Newsboys Goodfellows organization makes yearly pilgrimages to the monument on the anniversary of Brady's death.
- James J. Brady, founder of the Old Newsboys organization, rose from poverty to success and found pleasure in bringing Christmas cheer to Detroit's unfortunate children.

Department
Responsible
for
Maintenance:

Detroit Recreation Department.

Condition:

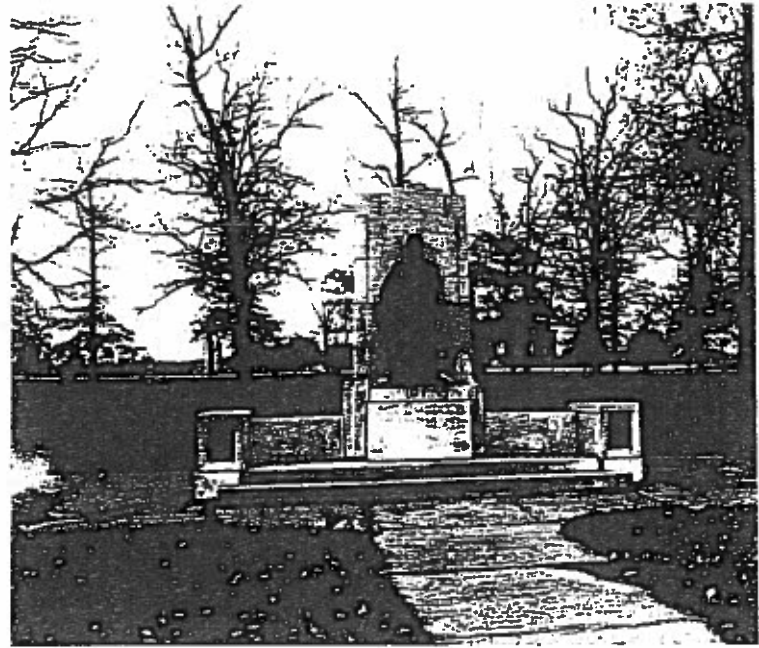
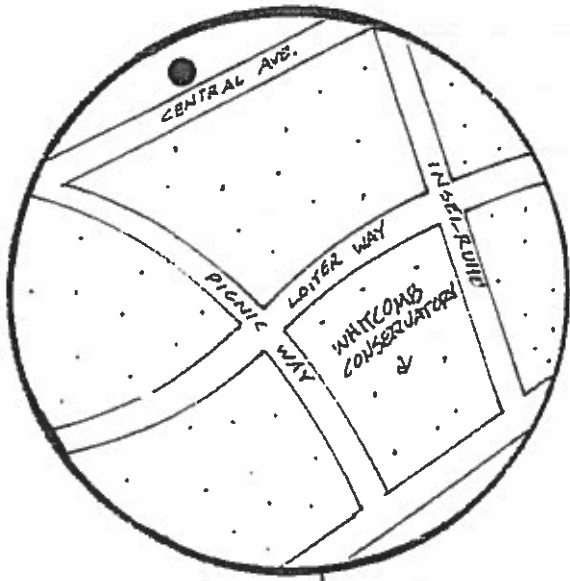

JAMES J. BRADY MONUMENT

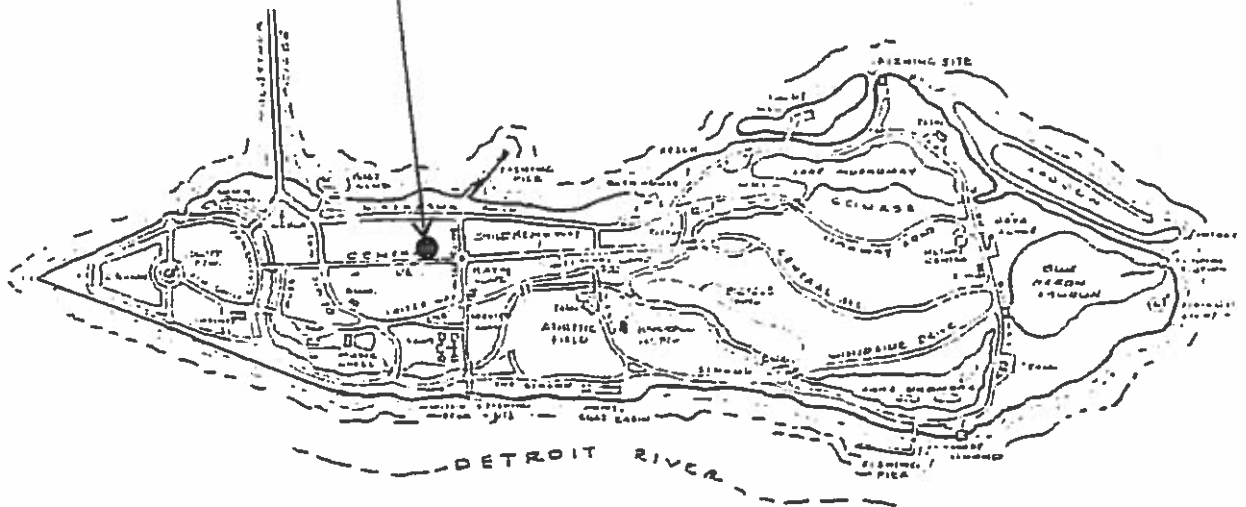

BELLE ISLE PARK

LE ANSE BROWNSTONE FOUNTAIN

Location: Belle Isle - S.E. of Loiterway and Picnic Way.

Sculptor: Unknown.

Biographical/
Information:

Material/
Technique: Indian red limestone.

Size:

Description:

Inscription: (on back of fountain)
1902. Presented by.

Important
Historical
Facts:

Department
Responsible
for
Maintenance:

Condition: Base broken and chipped up badly. The fountain is missing and its whereabouts are unknown.

CANNON (3)

Location:

1. Front lawn of the Old County Building, located on Randolph Street and Cadillac Square.
2. Front lawn of the Dossin Great Lakes Museum, located on Strand Drive, Belle Isle Park.
3. Same location as No. 2.

Sculptor:

Biographical/
Information:

Material/
Technique:

Size:

Description:

Inscription:

1. "Loaned to the City of Detroit from the U.S. government."
2. A 24-pound gun bears the following inscription which is deeply cut onto a heavy stone base. "Perry's Victory
Lake Erie
September 10th 1813"
3. A 32-pound carronade bears the same inscription as No. 2.

Important
Historical
Facts:

- Cannons 2 and 3 are from important naval victories on Lake Erie in 1813. Under the leadership of Commodore Oliver Hazard Perry, westward expansion was promoted, and the integrity of the then Northwest territories preserved.
- They were brought to Detroit years later and served as "snubbing posts" on waterfront docks until donated to the City of Detroit by citizens in 1872.
- It is rumored that several more Perry cannons lie buried at the foot of Cass Avenue.
- Formerly in front of the Old City Hall, the Cannons were moved into storage at Fort Wayne when Old City Hall was demolished.
- On May 25, 1961, a lead box was removed from beneath the Cannon at City Hall, which was turned over to the Detroit Historical Museum for preservation.
- Perry was only 28 when he commanded the American fleet against the British in 1813, and also distinguished himself at the Battle of the Thames River, thirty miles east of Detroit, on October 5, 1813. He died on his thirty-fourth birthday, October 23, 1814, of yellow fever, which he contracted in Venezuela.

Departments
Responsible
for
Maintenance:

Old City County Building and Dossin
Great Lakes Museum.

Condition:

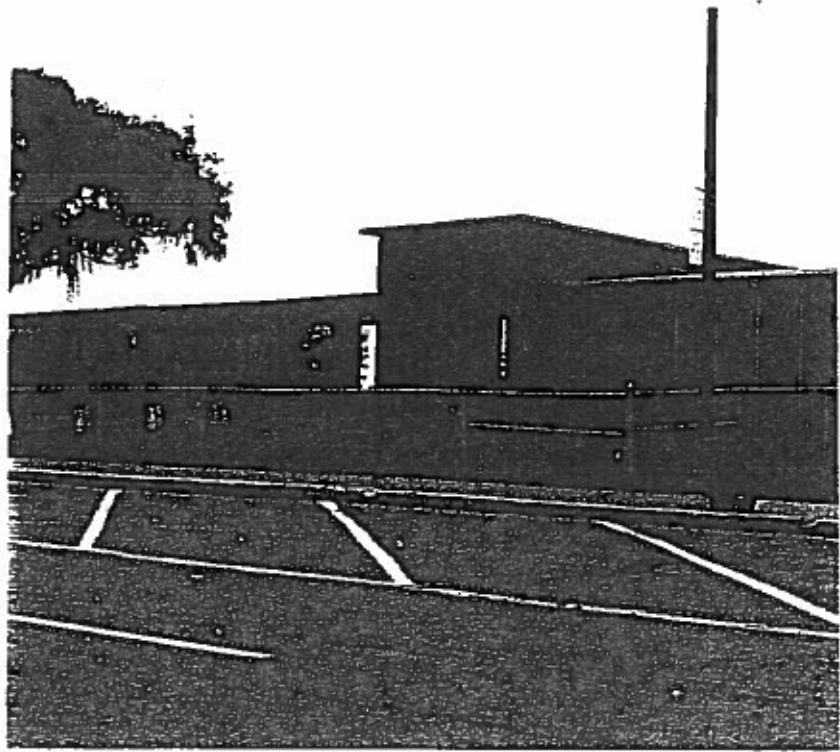
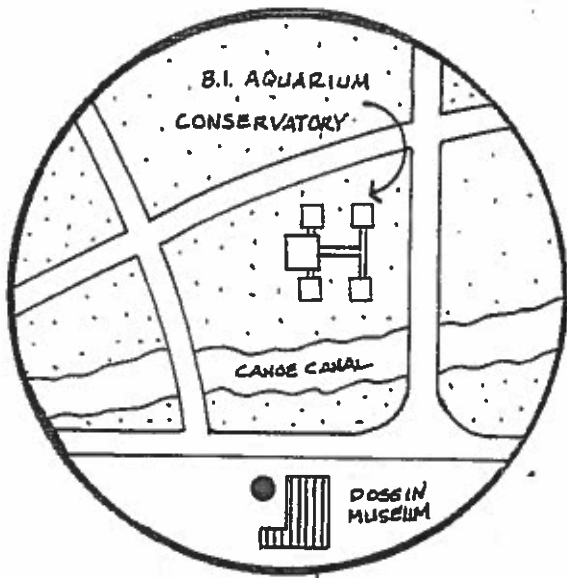

CANNON
BELLE ISLE-DOSSIN MUSEUM

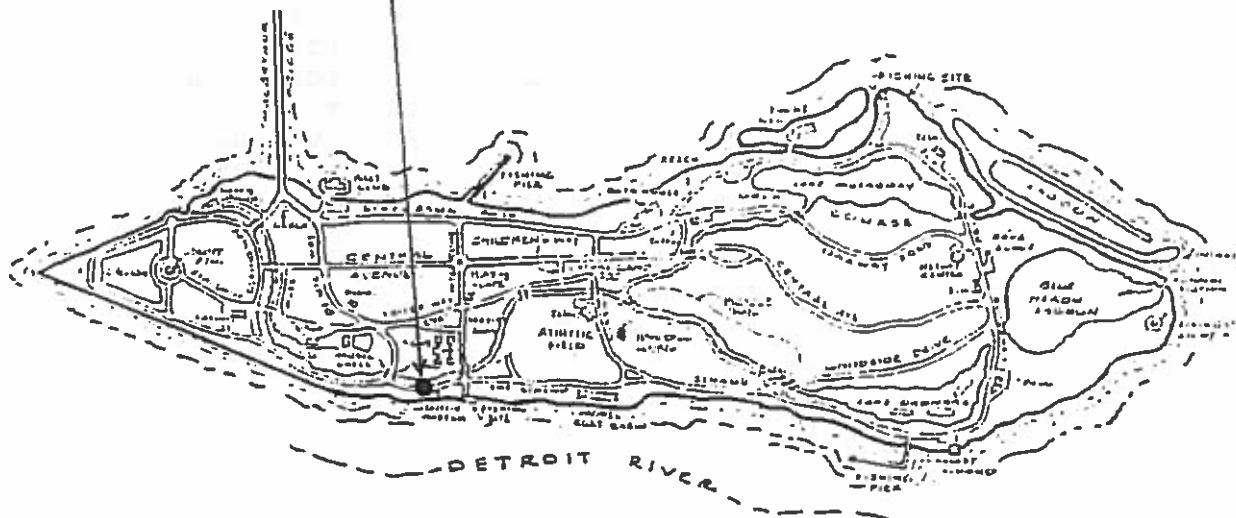

CIVIL WAR MONUMENT

Location: Belle Isle Park---Central Avenue and Muse Road.

Sculptor: Angelo Ziroli.

Biographical Information: Angelo Gerardo Ziroli was born in 1899, and studied in Italy. By the 1920s, however, he was likely working in the Chicago area where he won a number of awards and where a number of his sculptures now stand. In 1941, Ziroli was part of the exhibition of Michigan artists at the Detroit Institute of Arts, and Who's Who in American Art, 1947, lists him as living in Wyandotte, Michigan. Unfortunately, in 1948, the same year the Civil War Monument was unveiled, he died. He was only 49.

**Material/
Technique:** Carved granite.

Size:

Description: A lone soldier lost in thought shifts his weight upon his right leg which supports the muzzle of this musket against his shoulder while his left hand sets posed upon his upper left thigh. The frail and pitted condition of the work adds to the temporal, sensitive expression of the soldier's face. An iron fence surrounds the work atop a stepped granite base.

Inscription: There are now forty eight reasons why we will always remember the Grand Army of the Republic. Erected by Department of Michigan Women's Relief Corps Auxiliary to the Grand Army of the Republic. Dedicated November 11, 1948.

**Important
Historical
Facts:**

- This monument honors the men of Michigan who fought in the Civil War. It was erected by the Women's Relief Corp of the Grand Army of the Republic (G.A.R.).
- It was unveiled on Veterans Day, November 11, 1948.

**Department
Responsible
for
Maintenance:**

Detroit Recreation Department.

Condition:

Poor.

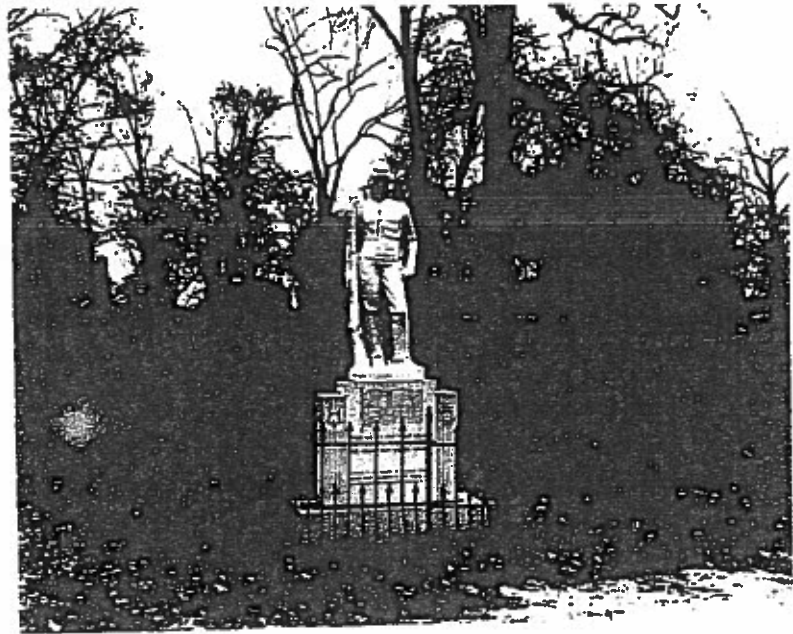
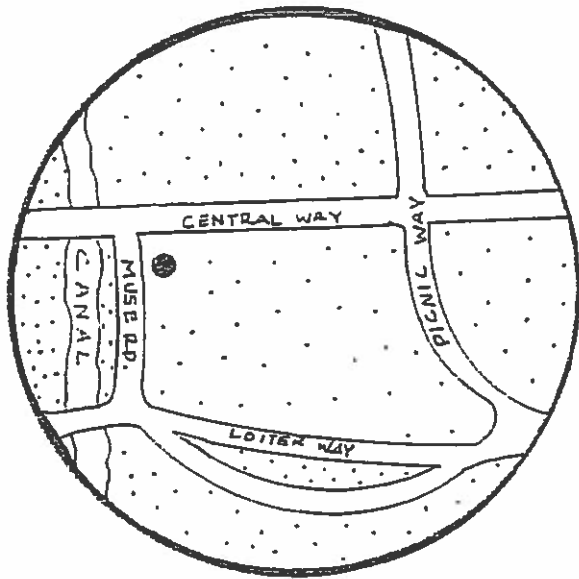

CIVIL WAR MONUMENT

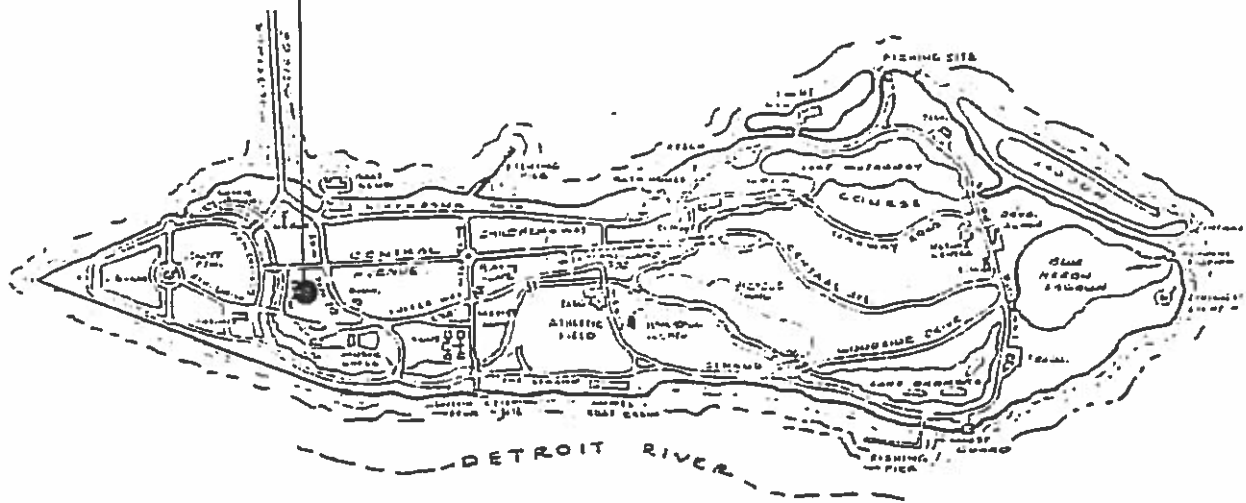

BELLE ISLE PARK.

EARTH SCULPTURE (CREATIVE PLAY SCULPTURE)

Location: North eastern end of Belle Isle, east side of Lakeside Drive near water intake, east of Lake Muskoday, north of the comfort station.

Sculptor: Stanley Dolega.

Biographical/
Information: Born in 1942, Dolega received his B.F.A. from Michigan State University in 1965, and in 1968, he obtained his M.F.A. from Wayne State University. He has held several teaching positions, has exhibited regularly and has won a number of awards in the area. He also has another work --- a steel work painted gray, located on the western tip of Belle Isle Park.

Material/
Technique: Earth and wood.

Size:

Description: A continuous grass covered mound, roughly in the shape of a "P", was formed into a hill. Inside the earth formed shape, the structure is deeper than the surrounding hillside and laid with planks of wood. The pole forming the stem of the structure extends horizontally and ambiguously like a cannon into space, with the support of three sets of vertical poles.

Inscription:

Important
Historical
Facts:

- Artist statement: "Each of my structure-sculptures is intended to appear to be some real, but unknown, object; an ambiguous statement balancing a thin line between real function and art object. Of course scale is very important. Each sculpture has to be large enough to demand physical exploration and discovery of structure and space. Since the real function can never be found, this feeds the ambiguity and creates a mystery about the piece."
- Given a grant in 1974, from the Michigan Council for the Arts, Dolega worked on this structure over the summer months. It was intended to be a play sculpture, and Dolega involved three Cass Technical High School students, and two hundred inner-city youths. A studio was set up on Belle Isle for the artist, students, and children to interact.

Department
Responsible
for
Maintenance:

Detroit Recreation Department.

Condition:

Fair.

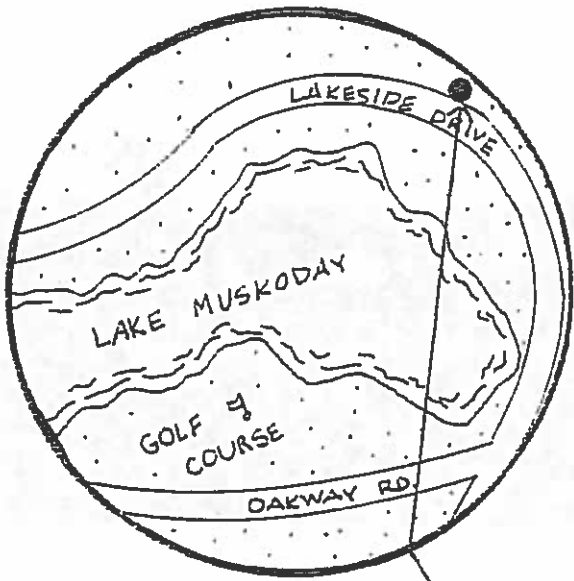
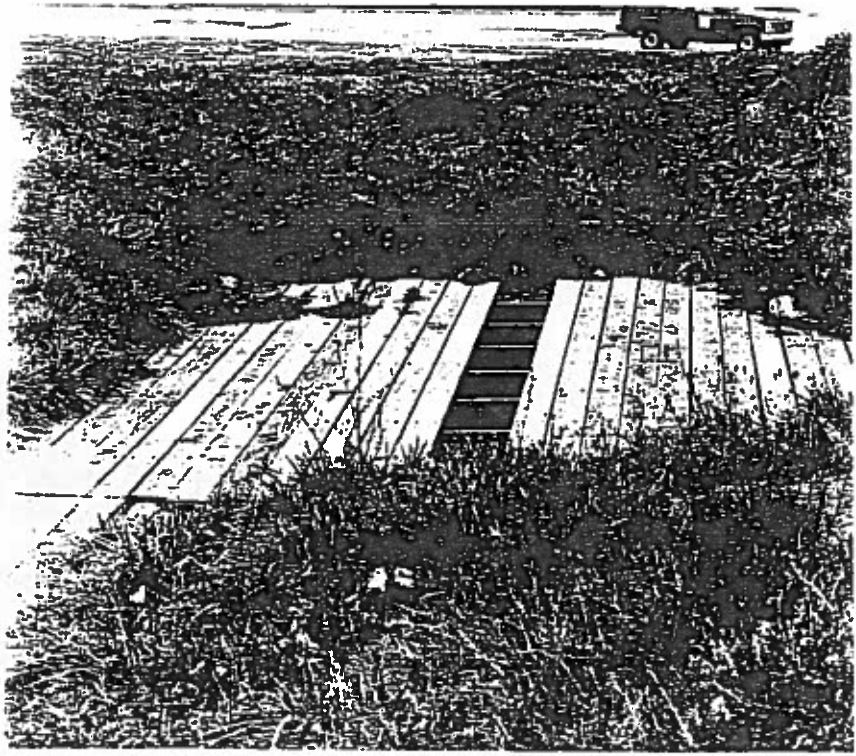

EARTH SCULPTURE
(CREATIVE PLAY SCULPTURE)

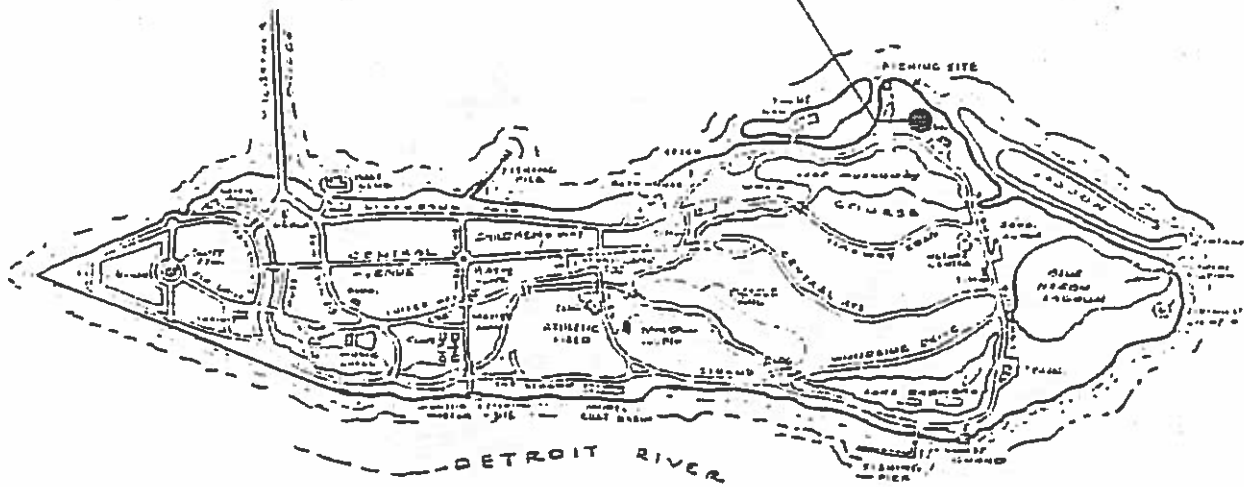

BELLE ISLE PARK

INTERNATIONAL PEACE MONUMENT

Location: Belle Isle, opposite Nancy Brown Peace Tower.

Sculptor: Erected by Monument Builders of America during their convention in Detroit, in 1941.

Material: Marble.

Description:

Inscription: "With this everlasting witness we keep peace with our neighbors as they have kept peace with us throughout the years."

Condition: Fence needs cleaning & straightening, & marble needs cleaning.

Department responsible for maintenance: Detroit Recreation Department.

W.K. MUIR MEMORIAL DRINKING FOUNTAIN

Location: Intersection of Casino Way and North River Bank Road.

Sculptor: Harrison Granite Company.

**Biographical/
Information:**

**Material/
Technique:** Barrie, Vermont granite. Carved architectural stone.

Size: Approximately 24 foot overall height.

Description: Vermont granite foundation, pyramidal style roof with two arches on two sides and four support columns, two half circle horse fountains; one on each side.

Inscription: Plaques above each fountain bowl. "W.K. Muir Fountain for the people MDCCCXGVI" (1896).

**Important
Historical
Facts:**

- William Kerr Muir, former Park Commissioner, was accepted by the City Parks and Recreation Board of Commissioners on July 21, 1897.
- Permission to construct the fountain was given by the Commission at its meeting of July 22, 1896. Subsequently, plans were presented by W. Howie Muir.
- Original cost in 1896 was estimated at \$3,000.00 .
- Placed in storage in 1946, when the new bridge over the canal on Casino Way was proposed.

Department
Responsible
for
Maintenance:

Detroit Recreation Department.

Condition:

Poor---completely disassemble. Would need historic conservation as well as replacement of missing pieces. 15 identifiable pieces, 28 nonidentifiable pieces; 43 total.

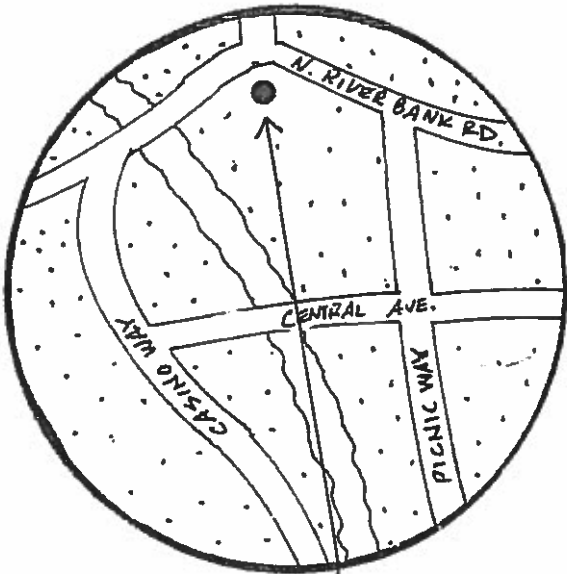

W. K. MUIR MEMORIAL DRINKING FOUNTAIN

(NO LONGER EXIST)

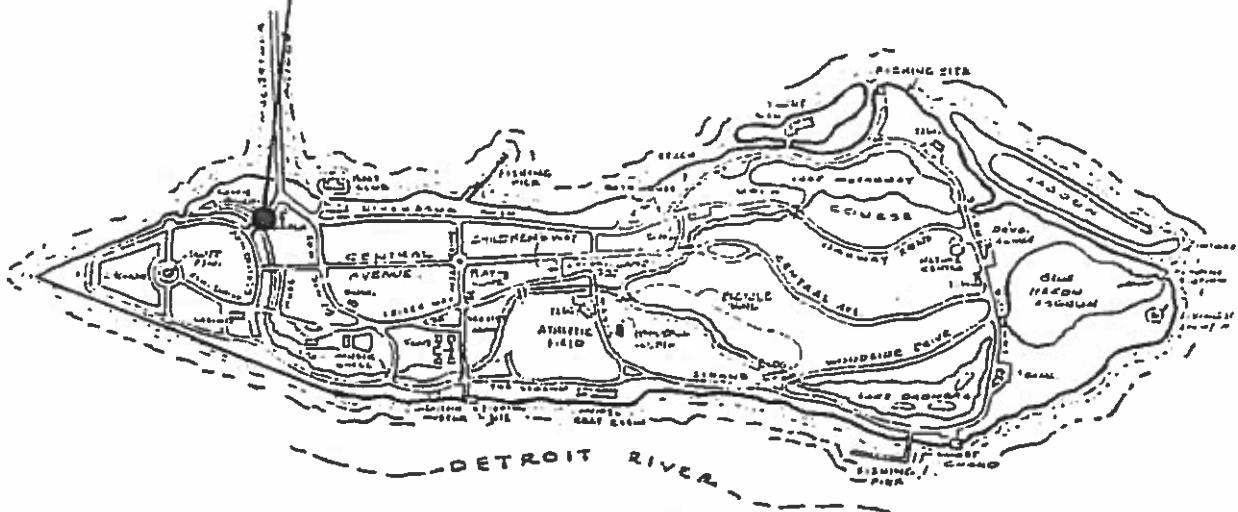

BELLE ISLE PARK

NEWSBOY AND HIS DOG DRINKING FOUNTAIN

Location: Belle Isle Park---Central Avenue, north of Muse Road.

Sculptor: Frederic A. T. Dunbar.

Biographical Information: Dunbar had a studio on the southeast corner of Woodward Avenue and Elizabeth. His son posed for the newsboy. From Detroit, Dunbar moved to Canada.

(L.C. Butler, 1929 Burton Historical Library Card Catalogue File.)

**Material/
Technique:** Bronze and granite.

Size: 4 ft. high, weight: approximately 100 pounds.

Description: A young newsboy drops coins from one hand into another. Under his left arm he holds a bundle of papers and over his shoulder is swung a blacking kit. At his feet, sits a dog.

Inscription:

Important Historical Facts:

- Presented to the City of Detroit by James E. Scripps, the estimated cost was \$3,500.
- The occasion for the unveiling was the Newsboy's outing. On July 6, 1897, about 5,000 Newsboys flocked to Belle Isle from Detroit, Flint, Saginaw, Bay City, Ann Arbor and Jackson. Mayor Maybury gave a speech and ended the outing by granting the bronze newsboy a formal license to sell papers and giving the dog a tag. Games followed (THE DETROIT NEWS, July 7, 1897.)
- The Newsboy has been stolen twice---

once in 1966, and again in 1974. A \$100 reward was offered for his return. Unfortunately, the dog stands alone to this day.

Department
Responsible
for
Maintenance:

Detroit Recreation Department.

Condition:

Newsboy statue is missing. Dog statue needs historic conservation work (conditions stated by Richard G. Hautau, Chief of Landscape Architecture of the Detroit Recreation Department, in September, 1987.

JOHANN FRIEDRICH von SCHILLER MONUMENT

- Location:** Belle Isle Park south east corner of the intersection on Central Avenue and Vista Avenue.
- Sculptor:** Herman N. Matzen.
- Biographical Information:** 1861-1938. Born in Denmark, Matzen studied under Julius T. Melchers before moving to Cleveland, Ohio, in 1886. His works are exhibited in Cleveland, Milwaukee, Akron, and Indianapolis.
- Material/Technique:** Bronze. "Molded in Munich and was brought to America on a North German Lloyd steamer, free of charge." (THE DETROIT NEWS, May 11, 1908.)
- Size:**
- Description:** In a sitting position, this sensitive poet reflects thoughtfully as he marks his place with his index finger in a closed book. Broad low steps lie beneath the base and figure, encouraging the viewer to approach and participate in Schiller's gage.
- Inscription:** Two quotations in German from Schiller's work are inscribed on the lateral sides of the pedestal. Also, inscribed: "Erected by the Citizens of German Descent, Detroit, Michigan, 1987."
- Important Historical Facts:**
- Designs for the statue were submitted in 1906. The head of the Monument Committee was George Osius.
 - The Cost, approximately \$12,000, came through numerous small subscriptions from citizens of German descent.

--Unveiled on May 11, 1908. The crowd numbered in the thousands and even the Emperor of Germany sent a cable in recognition of this action by the German-Americans.

--Schiller was a German writer who lived from 1759-1805. A close friend of Goethe, he advocated worldwide brotherhood, personal liberty, and human dignity in his many poems and dreams.

Department
Responsible
for
Maintenance:

Detroit Recreation Department.

Condition:

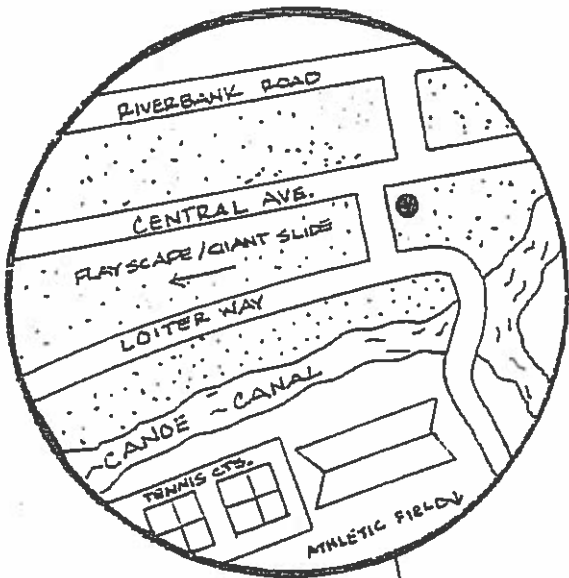
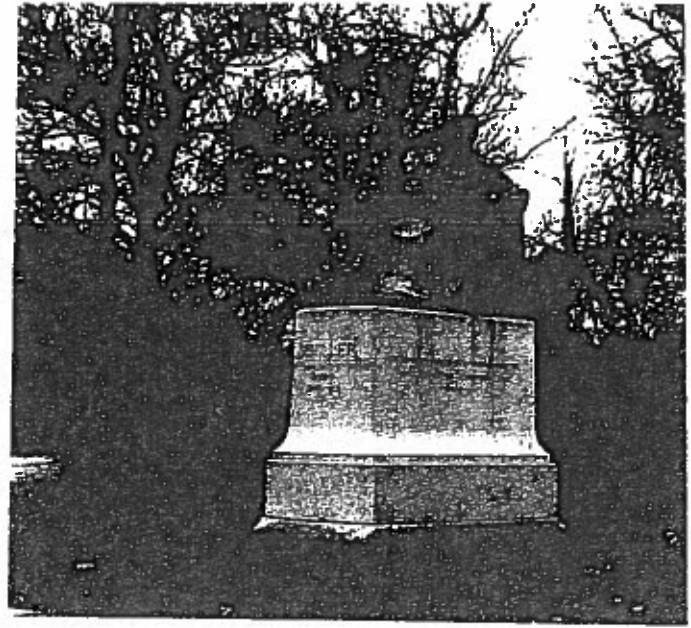

JOHANN FRIEDRICH VON SCHILLER
MONUMENT

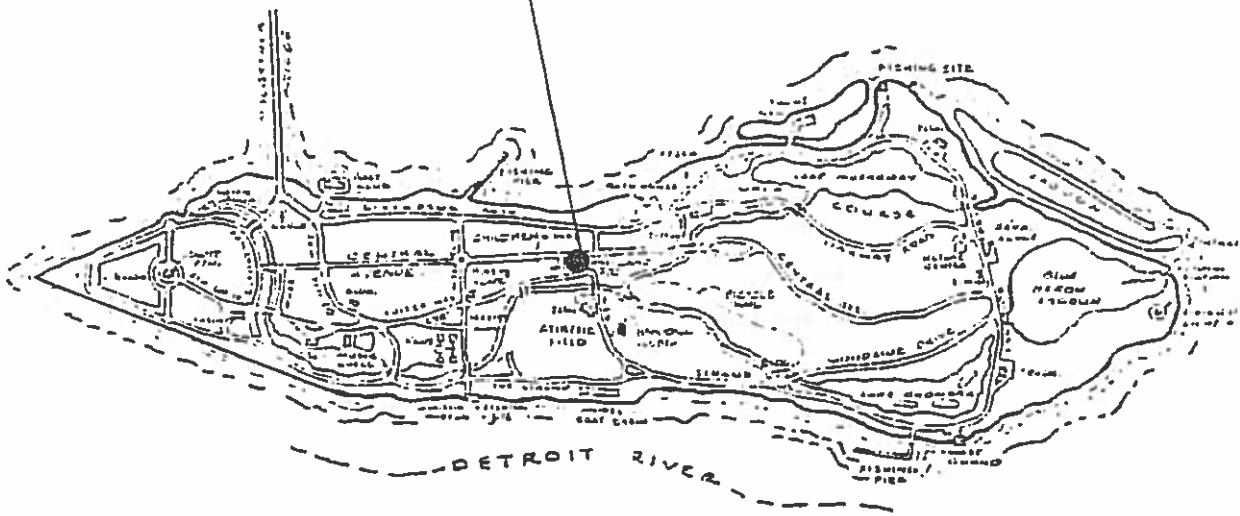

BELLE ISLE PARK

JAMES SCOTT STATUE
(Part of a fountain complex designed by Cass Gilbert)

Location: Belle Isle ParkDDDwest end. More specifically, on the Plaza level of the Scott Fountain.

Sculptor: Herbert Adams.

Biographical Information: 1858-1945. Born in Concord, Vermont, Adams was known for the refinement and beauty of the finish of his art. In 1926, he became the third sculptor to receive the Gold Metal of the National Institute of Arts and Letters. (In 1909 it was awarded to Augustus Saint-Gaudens and in 1917 to Daniel Chester French.) For more information on his career, see "The Sculpture of Herbert Adams," by Ernest Peixolto, The American Magayne of Art, Vol XII (May 1921) No. 5.

Material/Technique: Cast bronze.

Size:

Description: Bronze figure of James S. Scott in sitting position is located on steps leading to fountain. Inscription on back of chair.

Inscription: "For the enjoyment of the people and for the adornment of his native city, James Scott bequeathed to Detroit his fortune to be used in the construction of this fountain. Erected in 1923. From the good deed of one, comes benefit to many."

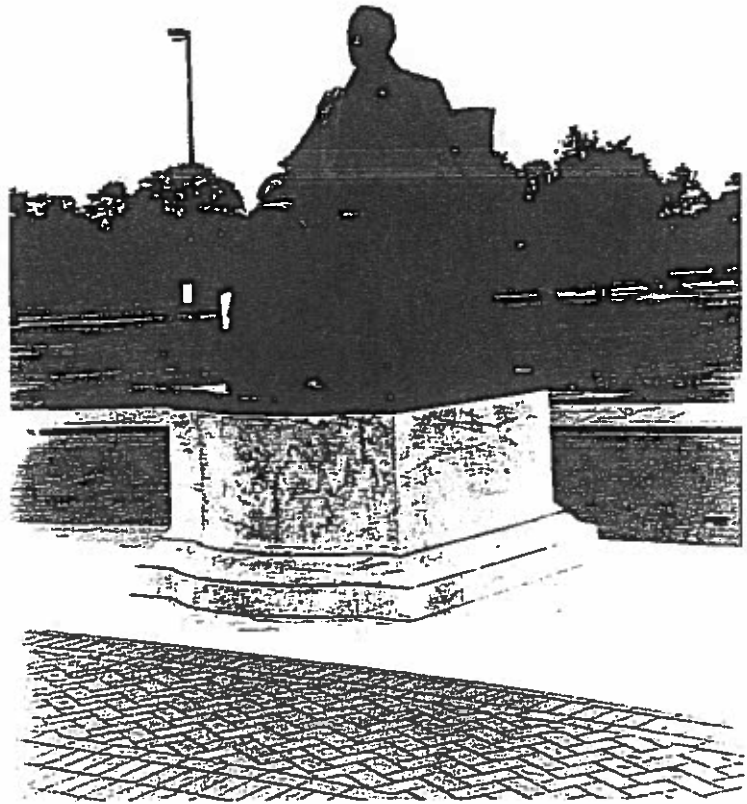
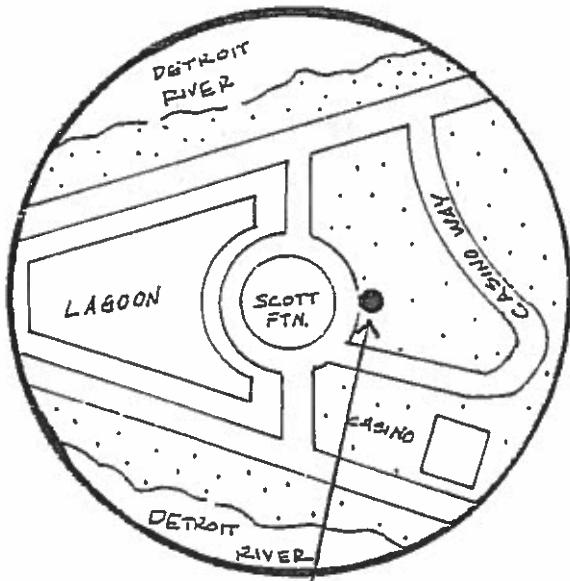

JAMES SCOTT STATUE
 (PART OF A FOUNTAIN COMPLEX
 DESIGNED BY CASS GILBERT)

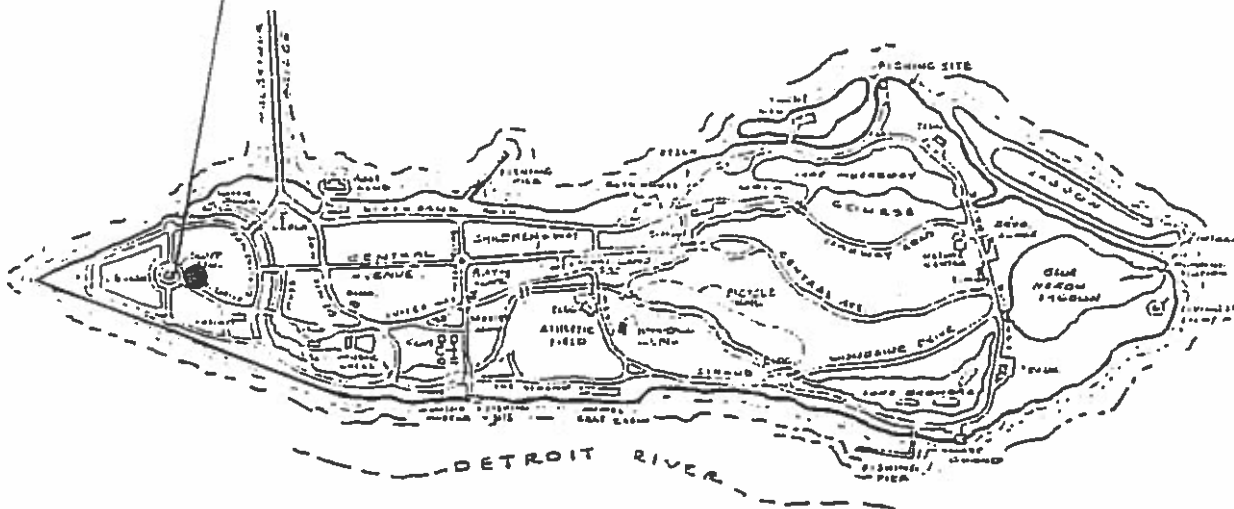

BELLE ISLE PARK

BELLE ISLE PARK
SCOTT, JAMES; MEMORIAL FOUNTAIN AND STATUE

Location: Belle Isle Park - westerly end.

Sculptor: Cass Gilbert of New York John R. Rockart, assisted Cass Gilbert (94 architects competed).

Biographical/
Information:

Material/
Technique: White Vermont marble.

Size: Said information is contained in the "Description" entry of this document.

Description: Fountain - white Vermont marble. The diameter of the entire fountain is 510 feet and of the outer pool, 112 feet. The height of the fountain from the lagoon is 37 feet 9 inches and the estimated height of the main column of water 125 feet. The diameter of the upper bowl is 13 feet. The diameter of the main body of the fountain is 56 feet and the upper bowl is 30 feet; 6 inches above the outer road. The fountain proper contains 109 outlets, there being one 3 inch, twenty-five 5/8 inch, sixteen 5/8 inch, 8 men's heads and dolphins with outlets varying from 1 1/2 to 2 1/2 inches, four lions with outlets 1/2 to 4 inches, 8 dolphins 1/2 to 2 inches, twenty-four rhytons of 5/8 inches and twenty-four turtles 5/8 inches each. There is a ring of sixteen vertical jets each 5/8 inch. In the upper cascade there are 33 jets and 1 in the bowl being 4 inches in diameter. The central jet of the upper bowl of the fountain is supplied from a centrifugal pump of 100 horse power. Another pump of 75 horse power supplies all the other outlets and these can be controlled individually or in groups. A third pump

of 50 horse power supplies the upper cascade and can also supply the lower whenever the latter is completely installed. The water from the lagoon enters the fountain through two 24 inch pipes. Settling tanks have been provided to keep any sediment away from the suction pipes and of the pumps. The water from the fountain proper flows back into the settling tanks and is used over again. The bowl weighed 51 tons as it stands now.

Cost, Dedications, etc:

1913	Plans for fountain (Cass Gilbert)	\$12,000.00
1920	Sculptor (Herbert Adams of Bronze Figure of James Scott)	20,000.00
1921	Architect (Cass Gilbert)	29,000.00
1921	Award of Contracts: (J.C.C. 7-26-1921, page 1414) John Bollin Company - Construction of Fountain.	345,200.00
	Pittelkow Heating and Engineering Company - Mechanical and Electrical Equipment	75,785.00

1921- 1923	40 Acres of Land Reclaimed for Site at Cost of	200,000.00
1923	Installation of Electric Cable to Scott Fountain	4,000.00
1925	Public Lighting Commission Fur- nished Electrical Current for Oper- ation of pumps at Scott Fountain at no cost to Parks and Boulevards.	-0-
1925	Other Costs	314,015.00
1925	Scott Fountain Dedicated Sunday, May 31, 1925	-0-
ORIGINAL FINAL COST		<u>\$1,000,000.00</u>

Costs after Scott Fountain Dedicated:

1925- 1926	Installation of Stone Dike Sur- rounding Fill Placed at and around Scott Fountain Contrac- tor - Dunbar and Sullivan (Contract Awarded J.C.C. 107-1925, page 2810)	\$11,250.00
---------------	--	-------------

1926	Payroll Labor by Parks and Boulevards Covering Cost of Placing Some of Stone of Old Bridge Piers Around Edge of Lagoon in Front of Scott Fountain. (J.C.C. 4-20-1926, page 1109. does not give cost of work.)	-0-
1926	Constructing and Installing in Place the Promenade around James Scott Water Fountain Contractor - Gallagher-Fleming Company (Contract awarded J.C.C. 5-11-1926, page 1400)	37,000.00
1928	Repair of Leaking Joints in Scott Fountain	233.60
1929	Landscaping Scott Fountain Grounds	15,000.00
1930	Completing Lower Cascade of James Scott Water Fountain (Contractor - Bryant and Detwiler Company (Contract Awarded J.C.C. 5-11-1930, page 2878)	53,829.00

1931	Installing New Pit Under Sidewalk and Under Fountain Slab, and Removing Present Top Slab and Replacing New 6-inch Slab at Scott Fountain	2,870.00
1934	Sidewalk Slab at Scott Fountain Sea Wall Job	550.00
1936	Installing Lamp Posts and Electrical Service about basin at Scott Fountain	850.00
1940	Complete Waterproofing - Recaulking of all Joints of Scott Fountain Contractor - Western Waterproofing Company (Contract Awarded J.C.C. 7-9-1940, pages 1894 thru 1897)	1,000.00
1955	Stage Construction at Scott Fountain Lagoon	4,500.00

1956	Installing Steel Sheet Piling, Scott Fountain Lagoon Contract PR-134 with E. C. Korneffel Company (Contract Awarded J.C.C. 6-12-1956, page 1250)	19,750.00
1976	Roadway and Sidewalk Replacement at Scott Fountain Contract PR-235 with J.J. Barney, Inc. of Detroit (Contract Awarded J.C.C. 6-2-1976, page 1128)	106,599.63
1976	Marble Cleaning and Joint Work at Scott Fountain Contract PR-236 with Grunwell-Cashero Company, Inc. of Detroit (Contract Awarded J.C.C. 7-28-1976, pages 1489-1490)	121,014.33
1976- 1977	Water Level Control, Scott Fountain Contract PR-238 with Hillyer Construction Corporation of Livonia (Contract Awarded J.C.C. 3-10-1976, page 442)	224,282.04

1978	August 10, 1978 at 9:00 p.m. of- ficial turning on of the Scott Fountain Multi- colored Lighting System	-0-
1979	Restoration of Perimeter Light- ing, Scott Foun- tain Contract PR- 260 with E. R. Switzer Electric of Detroit (Contract Awarded J.C.C. 7-18-1979, pages 2076 thru 2078)	59,570.00
1985	Lead work by CBM	50,000.00
	TOTAL	<u>\$708,298.60</u>

Inscription: (On the front and back of base - cut in letters)
James Scott 1831-1910.

(Wording on the back of chair - raised letters)
"For the enjoyment of the people and for the adornment of his native city, James Scott, bequeathed to Detroit his fortune to be used in the construction of this fountain. Erected in 1923. From the good deed of one, comes benefit to many."

Important
Historical
Facts:

--Jury of Awards: Charles A. Platt,
Walter Cook, Robert S. Peabody
(Architects); Frederic Law Olmstead,
Landscape Architect; Daniel C. French,
Sculptor.

Department
Responsible
for
Maintenance:

Detroit Recreation Department.

Condition:

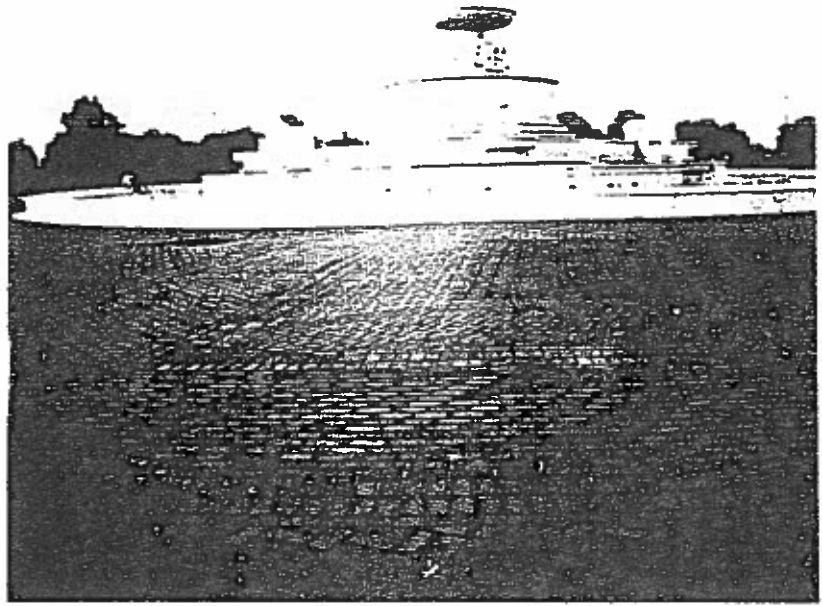
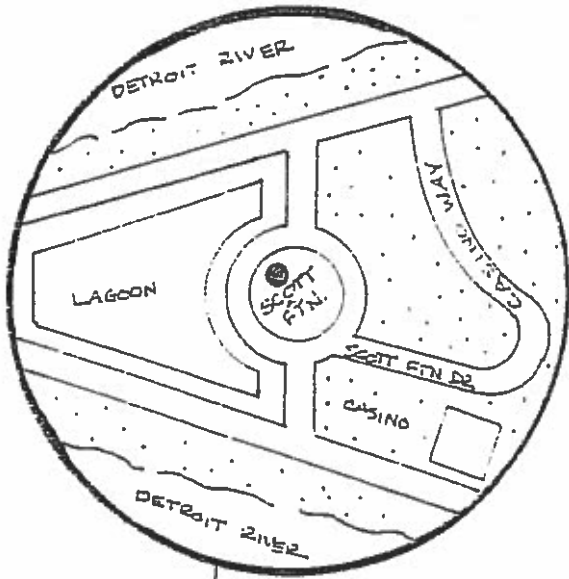

SCOTT, JAMES, MEMORIAL FOUNTAIN

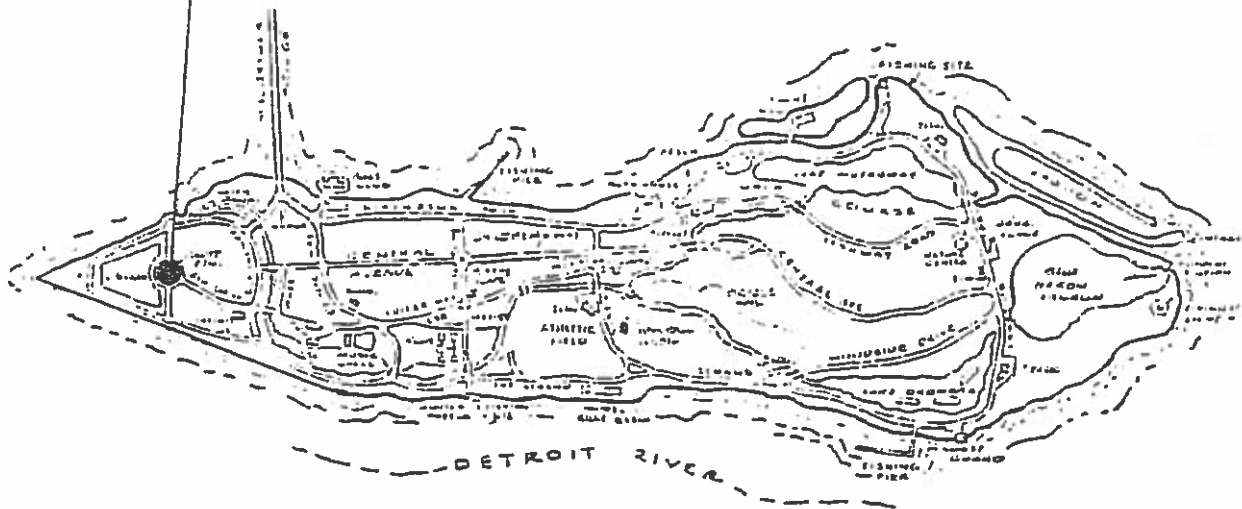

BELLE ISLE PARK

REV. SAMUEL FRANCIS SMITH MONUMENT (flagpole)

Location: Belle Isle Park. South shore, east of Athletic Field.

Sculptor: Unknown.

Biographical/
Information:

Material/
Technique:

Size:

Description: A picture of Smith is on the front of the Monument.

Inscription: (on front) (raised letters).

Samuel Francis Smith. Author of America. The gift of the school children of Metropolitan Detroit. Sponsored by the Detroit Rotary Club.

(on back) (raised letters)

Words to the song "America".

Important
Historical
Facts:

Department
Responsible
for
Maintenance:

Detroit Recreation Department.

Condition:

Approximately 56 letters need to be replaced. Joints need to be repaired and pole needs to be painted. Also, the stone needs to be cleaned and the light on the top of the pole needs to be repaired.

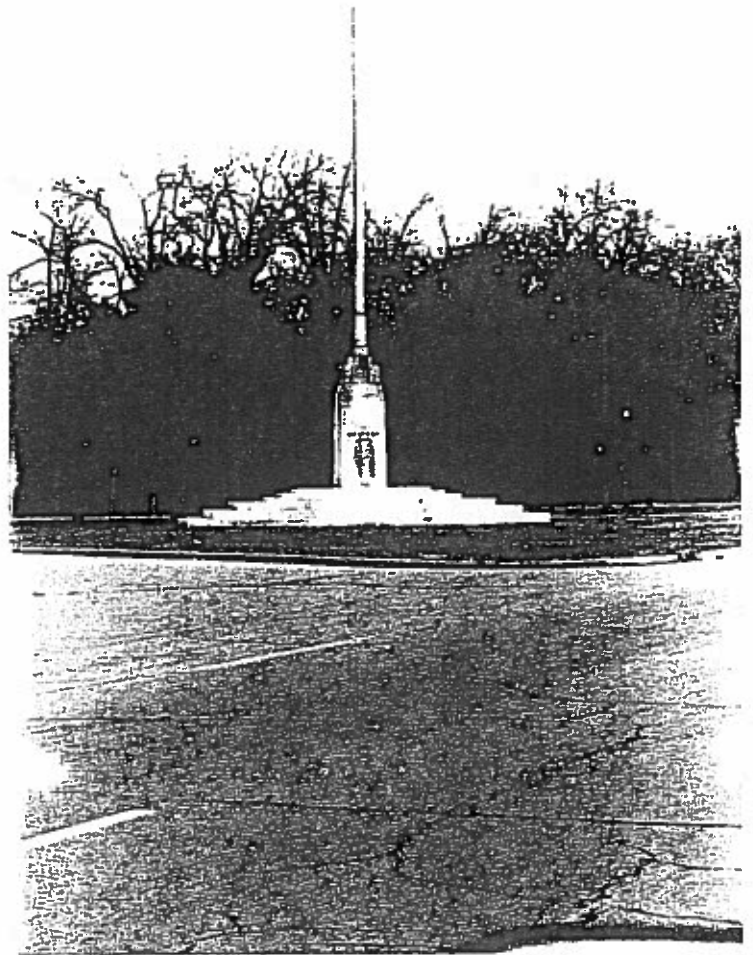
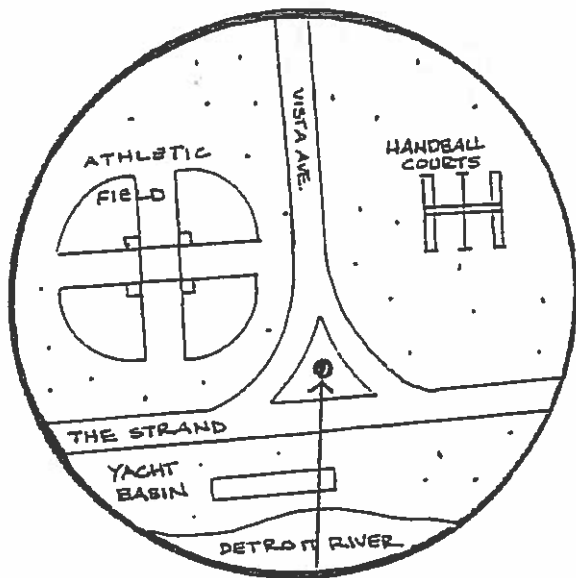

REV. SAMUEL FRANCIS SMITH
MONUMENT (FLAGPOLE)

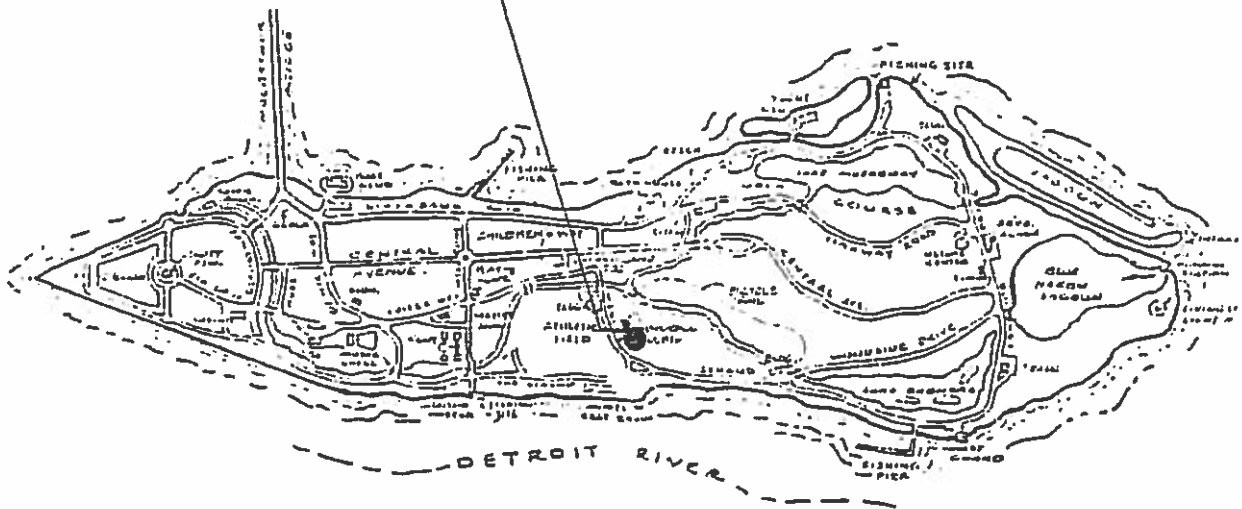

BELLE ISLE PARK

SPANISH-AMERICAN WAR MEMORIAL

Location: Belle Isle Park - Central Avenue near bridge approach.

Sculptor: Allan G. Newman.

**Biographical/
Information:** 1875-1940. New York. Newman was a pupil of J.Q.A. Ward and a member of the Beaux-Arts Institute. His work stands in New York City, Rhode Island, Atlanta, Montgomery, Pittsburgh, and West Point, New York.

**Material/
Technique:** Bronze and granite.

Size:

Description: White granite monument is flanked by two bronze figures of a soldier (west side) and sailor (east side) from 1898.

Inscription: "Cuba Puerto Rico. Erected by the people of Wayne County, Michigan in commemoration of the service of her Volunteer Sons in the Army, Navy and Marine Corps of the United States during the War with Spain-1898-1902."
and
"China Phillipines. In commemoration of the Volunteer Services of Wayne County's Sons during the Insurrection in the Phillipines and the Chinese Relief Expedition-1889-1902.

**Important
Historical
Facts:** --The monument was designed to commemorate 2,500 troops sent to three fronts in the brief Spanish-American War of 1898.

--1929, \$15,000 which had been appropriated by County Board of Supervisors for the monuments was threatened.
--May 8, 1931, design approved by City Plan Commission.
--Lloyd Bros., Detroit, Michigan, erected the memorial.
--June 12, 1932, the monument was formally presented.

Department
Responsible
for
Maintenance:

Detroit Recreation Department.

Condition:

Portions of inscription on Puerto Rican side are missing.

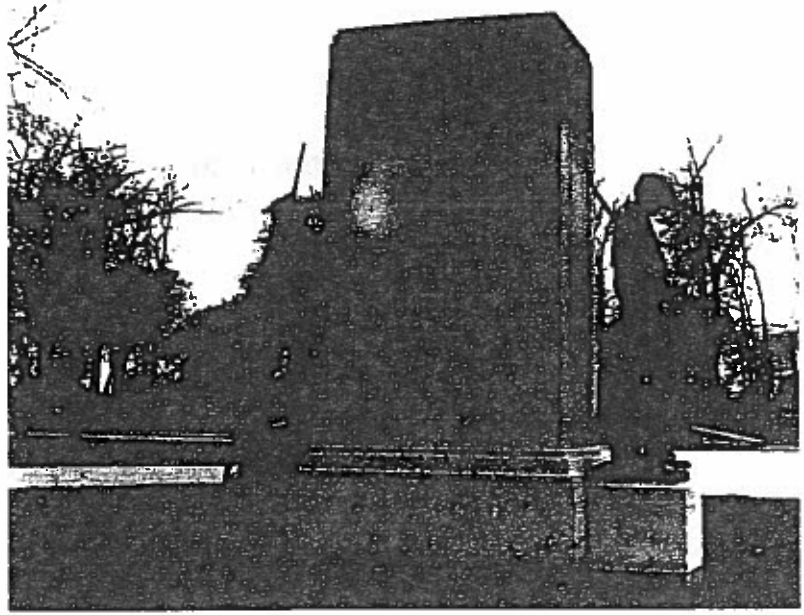
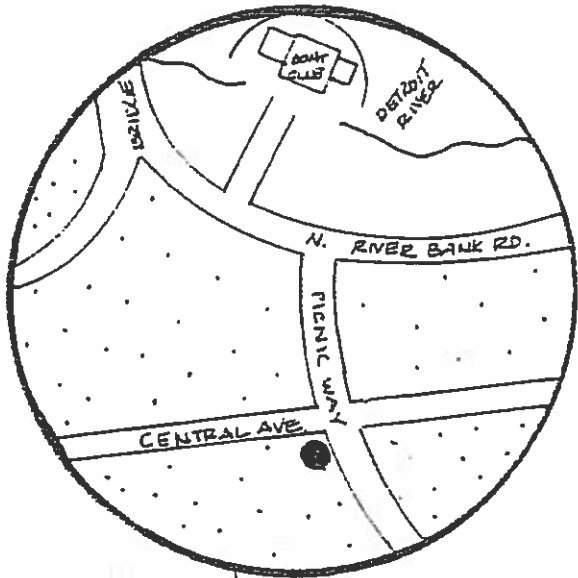

SPANISH-AMERICAN WAR MEMORIAL

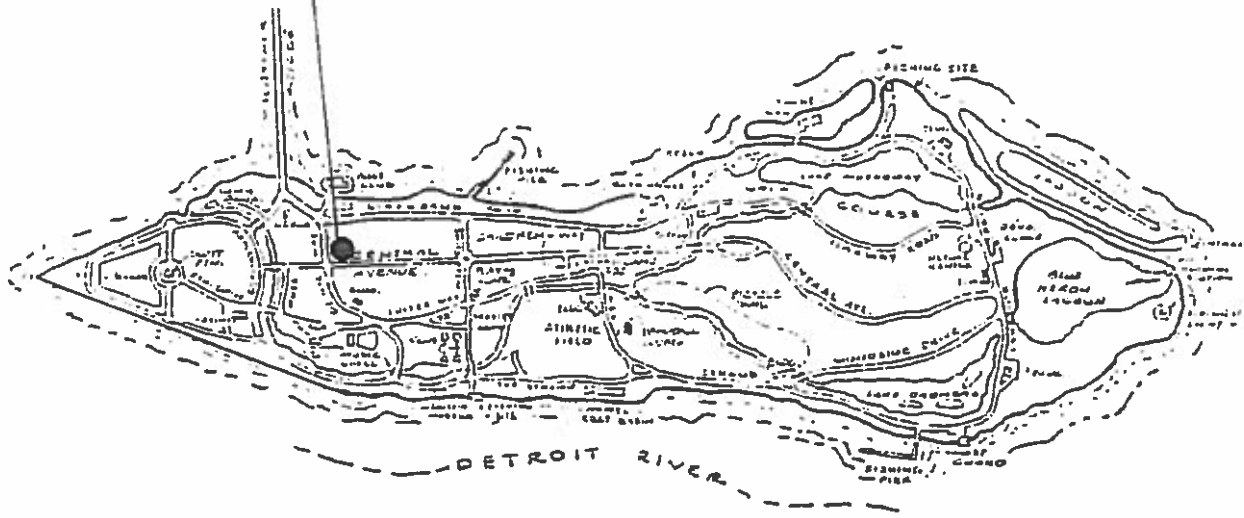

BELLE ISLE PARK

MAJOR GENERAL ALPHEUS STARKEY WILLIAMS

Location: Belle Isle Park ~~Island~~ at the intersection of Central and Inselruhe Avenues.

Sculptor: Henry Merwin Shrady.

Biographical Information: October 24, 1871-April 12, 1922. Shrady started his career as a New York lawyer, but was diverted into business until 1900. Then after an illness and the failure of the company were he worked, Shrady took up sculpture and sketching. In 1901, his large sculptured moose and buffalo for the Pan-American Exposition attracted attention. He then went on to win a competition in Brooklyn. He was also elected a member of National Sculpture Society and in 1909, he became a member of the National Academy of Design. His most famous achievement was the Grant Memorial in Washington, D.C. While working on the Grant Monument, he simultaneously work on the Williams Monument in Detroit, Michigan. He is considered to be among the most prolific equestrian sculptors of all time. Shrady died shortly after the unveiling of the Detroit work and two weeks before the elaborate ceremonies celebrating his work in Washington, D.C.

Material/
Technique: Cast bronze and granite.

Size:

Description: Equestrian statue depicts General Williams sitting astride his horse studying a map of the battlefields during a storm.

Inscription:

(on front base)
Major General Alpheus Starky Williams -
1810-1878.

(on south side of base)
The Michigan Commander of the military
order of the loyal legion of the United
States and citizens of Detroit have
erected this tribute to the valor and
abilities of Alpheus S. Williams. Lieut.
Colonel, First Michigan Infantry Volun-
teers, in the war with Mexico. Brig.
General and Brevet Maj. General United
States Volunteers in the Civil War.

(on north side of base)
Hero of two wars. Judge, editor, post-
master, diplomat member of Congress. An
untiring servant of the People, an honor
to the City of Detroit.

Important
Historical
Facts:

- The project was suggested as early as
January 3, 1879.
- The project was inaugurated on March
22, 1911.
- An association was formed April 17,
1911, by loyal Legions and other con-
cerned citizens for the purpose of
erecting an equestrian statue of
General Williams who had served in
both the Mexican and Civil Wars, and
was the only officer from Michigan who
commanded any army corps during the
War of the Rebellion.
- Officers of said Association: Samuel
E. Pittman, President; Charles Moore,
Treasurer; Frank Hecker and William
Livingston, Vice Presidents.
- A fund of \$30,000 was established and
on April 19, 1912, Shradly was commis-
sioned to execute the equestrian monu-
ment.
- 1915, a miniature copy of the monument
was on display at the Arts Museum.
- The City appropriated another \$25,000
for the construction of the site,
foundation and pedestal.

--The project was delayed because of shortages caused by WWI, union strikes, and Shradys's failing health.
--Completed October 15, 1921.

Department
Responsible
for
Maintenance:

Detroit Recreation Department.

Condition:

On 6/86, Richard G. Hautau, Chief of Landscape Architecture for the Detroit Recreation Department, reported that the base needs cleaning and two bollards on the south side are missing. Bronze work needs historic conservation work.

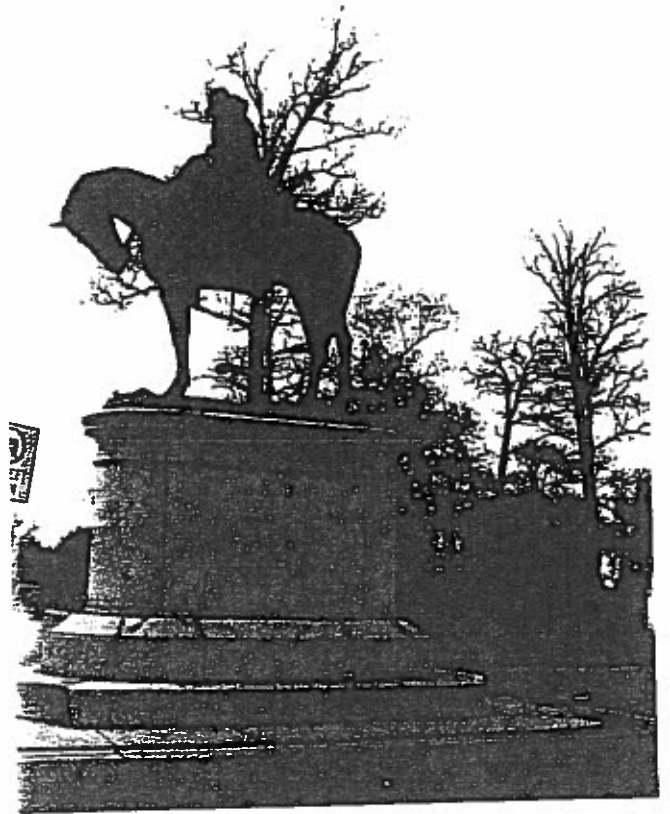
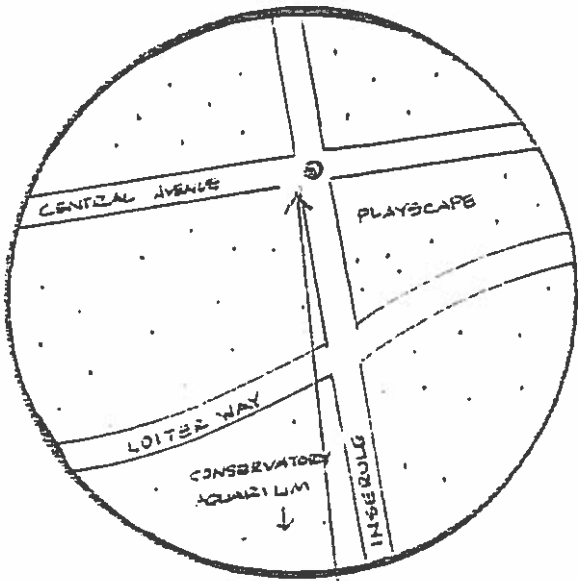

MAJOR GENERAL ALPHEUS STARKY
WILLIAMS

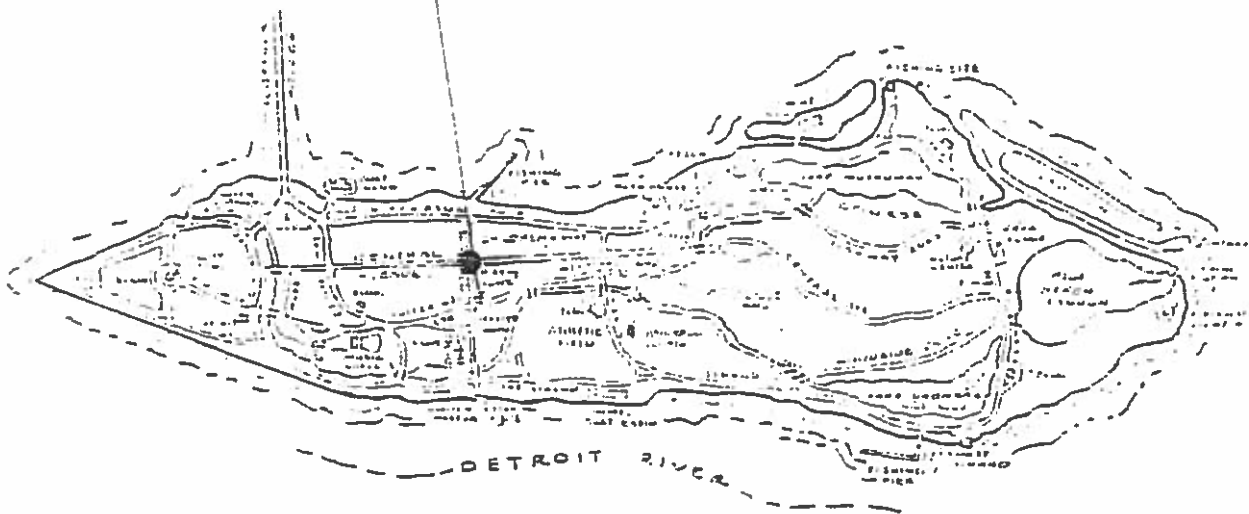

BELLE ISLE PARK

Location: Sun Dial on Granite Base is currently in storage in the Conservatory Service Yard located between the Aquarium and the Conservatory. Originally the Sun Dial on Granite Base was located on the center line of west entrance door to the Ann Whitcomb Scripps Conservatory at the west end of the formal gardens.

Sculptor: Unknown.

Biographical/
Information:

Material/
Technique: Granite base. Bronze dedication plaque.

Size: Base is approximately four foot in height. Plaque on base measures 10" x 13 1/4 on the top and 10" x 14 3/4 on the bottom.

Description: Tapered granite base.

Inscription: Bronze plaque inscribed: Presented by F. X. Kolb Detroit, Michigan 1927.

Important
Historical
Facts:

Department
Responsible
for
Maintenance: Detroit Recreation Department.

Condition: Plaque needs conservation treatment. Base needs cleaning. Sun dial is missing. Recommend selection of new sun dial from Kenneth Lynch Catalogue and reinstallation in formal garden.

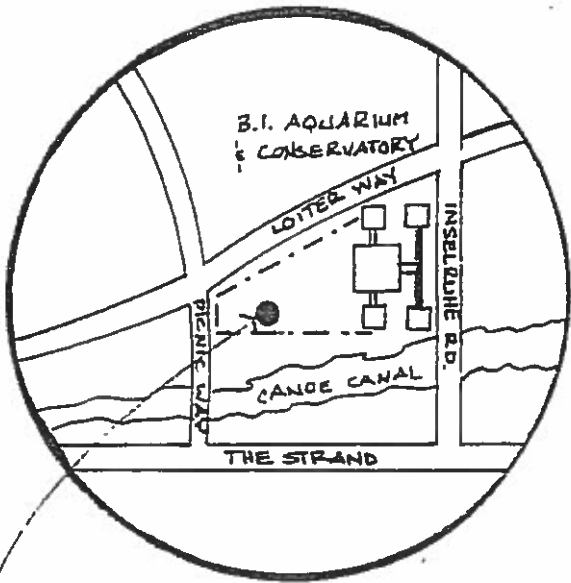

SUN DIAL ON GRANITE BASE

KOLB MONUMENT

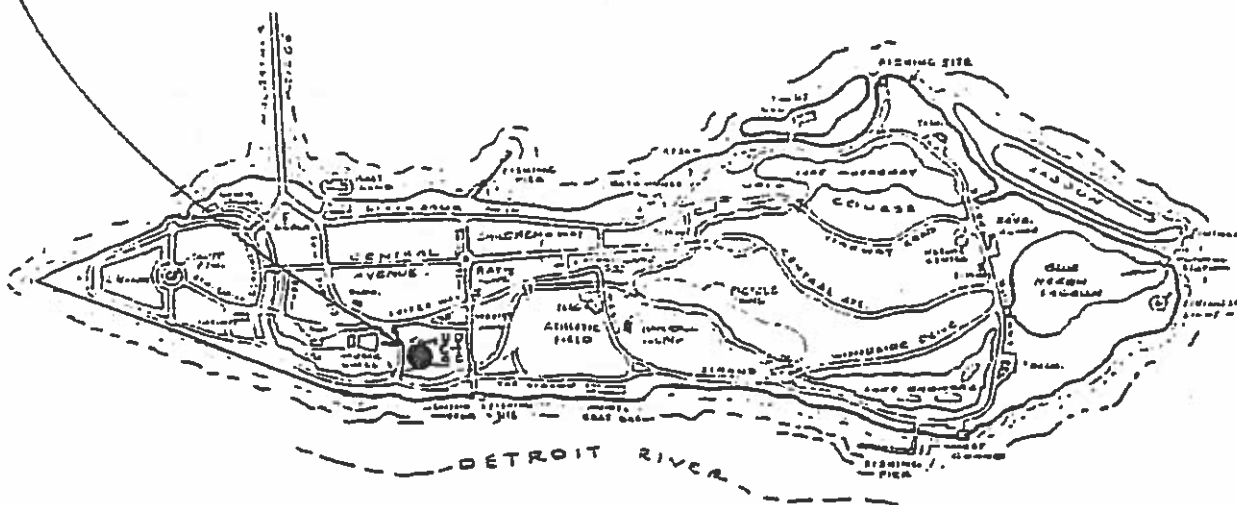
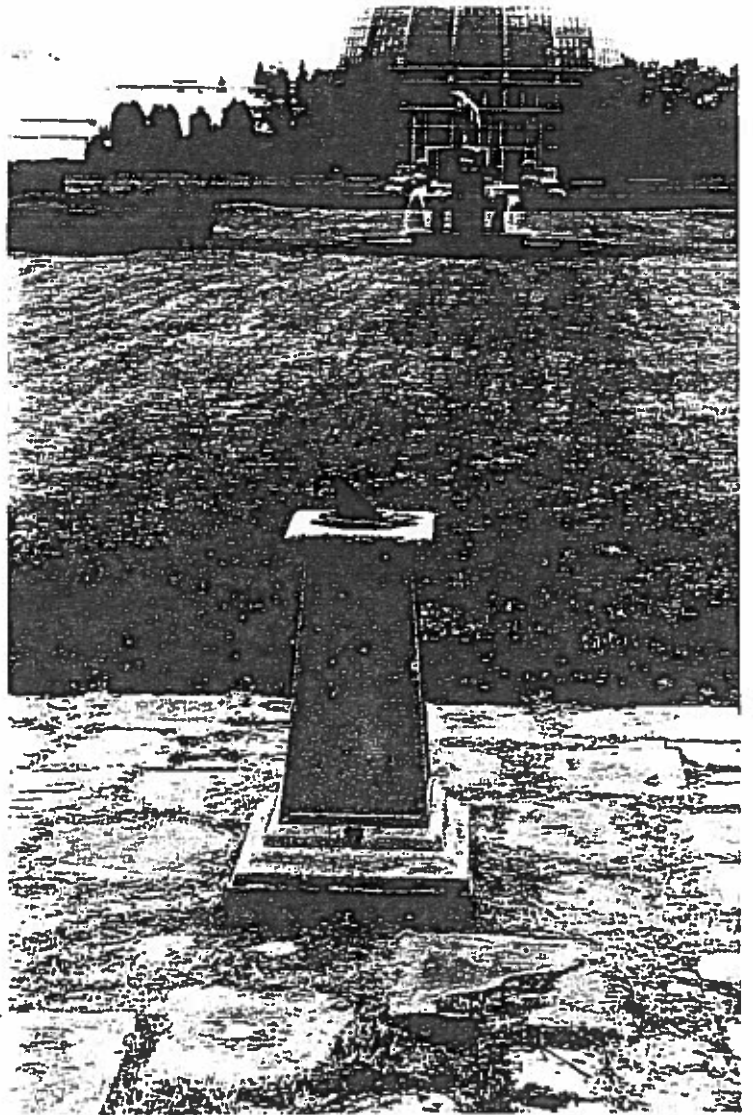

JAPANESE TOHRO (STONE LANTERN)

Location: Outside main door of the conservatory, Belle Isle Park.

Sculptor: Unknown.

Biographical/
Information: Unknown.

Material/
Technique: Cut white granite.

Size: 6 ft. tall, 4000 lbs.

Description: The six foot tall Japanese Stone Lantern bears the inscription "friendship" in Japanese at its base.

Inscription: "Friendship" in Japanese.

Important
Historical
Facts: --The Tohro was presented to Detroit on September 19-21, 1985, to celebrate the 25th Anniversary of the Detroit/Toyota Sister City Relationship. Lakashi Nishiyama, Toyota's Mayor, and 15 members of the Toyota City Council were present at the ceremonies. Mayor Coleman Young presented Toyota's Mayor with a small replica of Marshall Frederick's leaping gazelle, which was created for the Levi Barbour Fountain located in the Belle Isle Gardens.

--The Sister City Program is a member of Sister Cities International, a non-profit organization which seeks to promote better understanding by pairing American cities with foreign ones.

--The Stone Lantern is one of the most favored of all scenic objects for the Japanese garden. It is both a practical and an ornamental piece originally employed to illuminate the garden path.

Department
Responsible
for
Maintenance:

Detroit Recreation Department.

Condition:

TOTEM POLES

Location: West end of the Children's Zoo, Belle Isle Park.

Sculptor: Haida Indians.

Biographical/
Information: The Haida Indians live in Western Canada and the Northwestern United State. These poles come from Alaska.

Material/
Technique: Carved Cedar and paint.

Size:

Description: One large and one smaller, the Totem Poles were carved in relief out of the trunks of trees. The faces of people, animals, and legendary beasts were then painted.

Inscription: None.

Important
Historical
Facts:

- Traditionally, totems are carved by village artists and illustrated tribal legends or family genealogist. They are set into place amidst feasting and celebration.
- The Totems Poles were gifts to the Zoo from the Alexander Blain family.
- The smaller totem was originally on Blain Island near Waterford, Michigan.
- The larger totem was shipped directly to the Zoo from Ketchikan, Alaska.

Department
Responsible
for
Maintenance:

Zoological Gardens.

Condition:

TOTEM POLES
CEDAR WOOD
INDIANS - ALASKA

ZOO

The totem poles at the west end of the Zoo blend naturally into their surroundings. The larger totem is near the elk exhibit, and the smaller at the south end of Pierson Lake (formerly North America Lake). These totems are gifts to the Zoo from the Alexander Blain family. The smaller one was originally on Blain Island at Maceday Lake near Waterford, Michigan. When the island was donated as a camp for under-privileged children, the totem was donated to the children's Zoo at Belle Isle.

The large totem was shipped directly to the Belle Isle Children's Zoo from Ketchikan, Alaska.

Both totems ended up in storage when the new Zoo was built at Belle Isle in 1980. The totem poles were carved out of cedar trees by Haida Indians of Alaska.

Traditionally, totems were carved by village artists, and illustrated tribal legends, or family geneologies. They were set in place amidst feasting and celebration.

The totems at the Detroit Zoo were not set in place with such festivities but we must all celebrate the good fortune at possessing these works of native American artists.

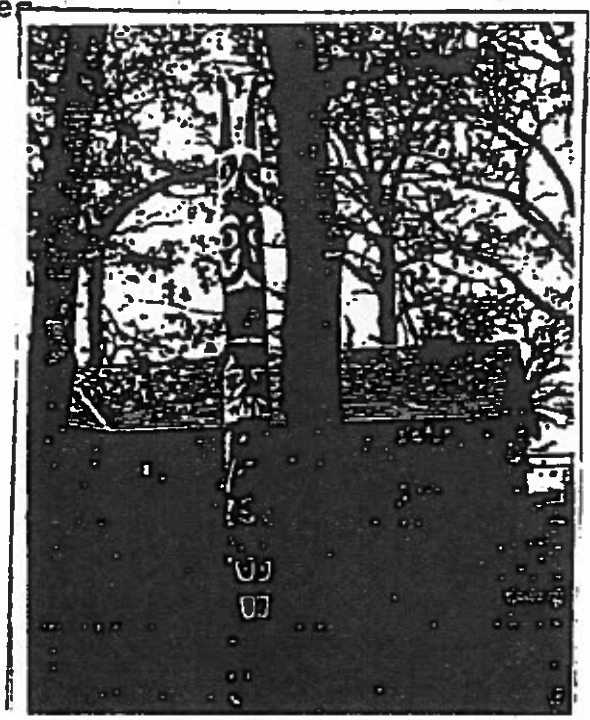

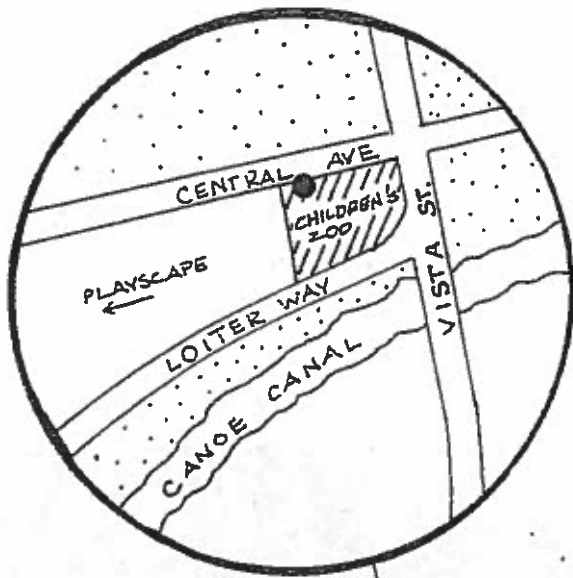

TOTEM POLES

BELLE ISLE CHILDREN'S ZOO

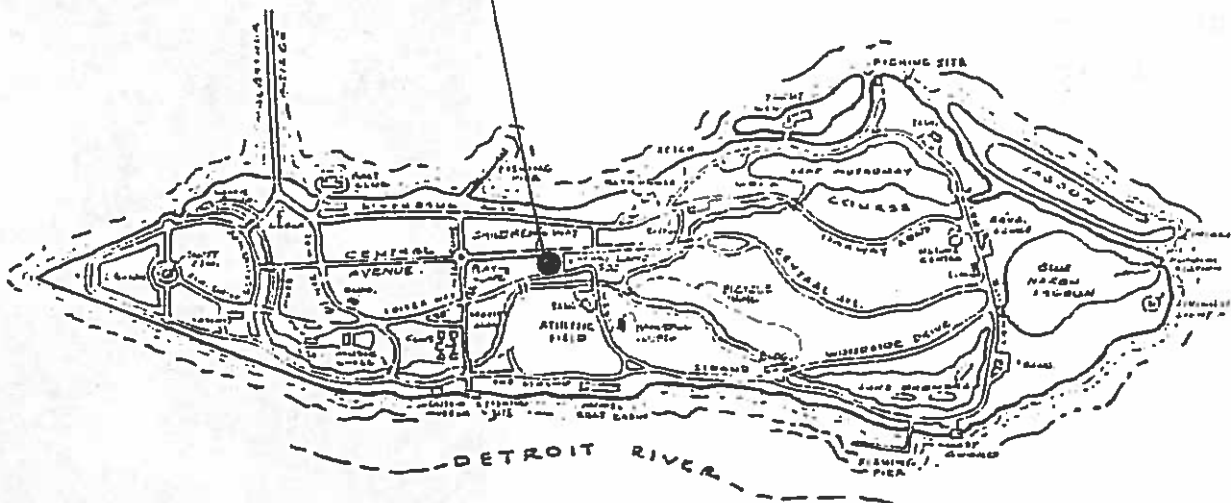

BELLE ISLE PARK

MODERN ART

ABZ EVERYTHING IS ANYTHING

Location: Pingree Park, East Warren Avenue at Seneca Street.

Sculptor: John Piet.

Biographical/
Information: 1946- . Piet resides in Detroit, Michigan, received his M.F.A. from Wayne State University and presently teaches at Macomb Community County College (1984).

Material/
Technique: Welded and painted steel. It is a redish orange color.

Size: 18 ft. high.

Description: Forming a lyrical letter "A" from one angle. This painted red work is intended to symbolize a beginning, or entrance. Supported by a third leg, it is also surmounted by a playful, short, upward, curved beam.

Inscription: None.

Important
Historical
Facts: --This work is part of Piet's space series, a series in which he explored an interest in science fiction.
--Executed in 1972, this sculpture was donated to the City of Detroit by New Detroit, Inc. in the summer of 1973.
--The Art for Living Program under New Detroit, Inc. desired to turn Detroit into a city of art through strategically placed murals and sculpture. Rather than concentrating on the Civic Center, New Detroit, Inc.

wanted to stimulate neighborhoods and, therefore, provide a showcase for local artists, and in so doing, instill pride. The Art for Living Program was formed in the late 1971 and remained active for over two years.

- The artist has described this work as a tripod about to move.
- Sculpture needs paint to prevent further rust.

Department
Responsible
for
Maintenance:

Detroit Recreation Department.

Condition:

Per Richard G. Hautau, Chief of Landscape Architecture, the statue needs repainting.

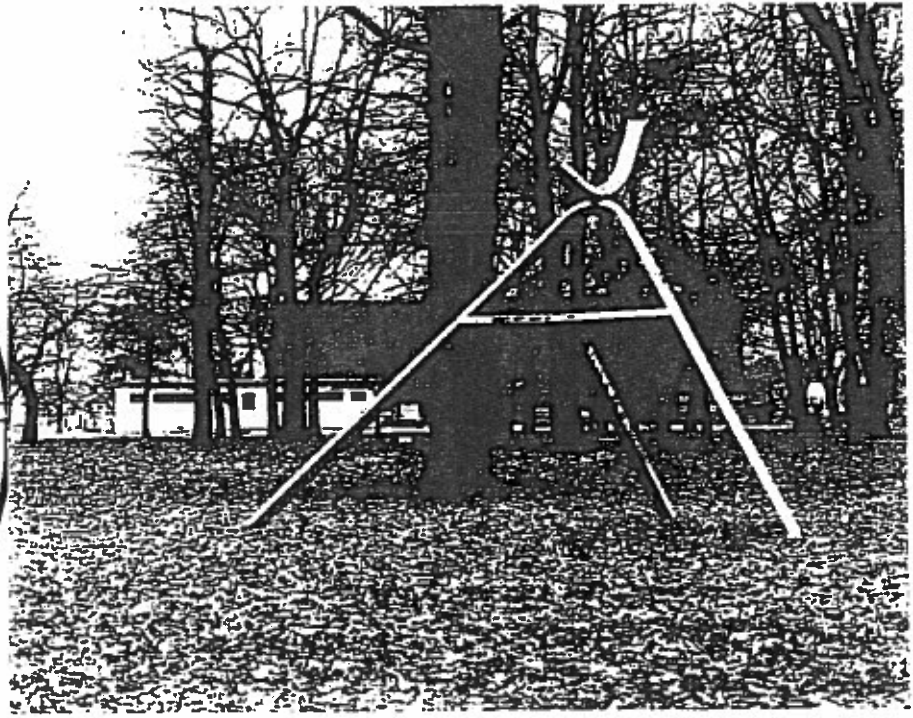
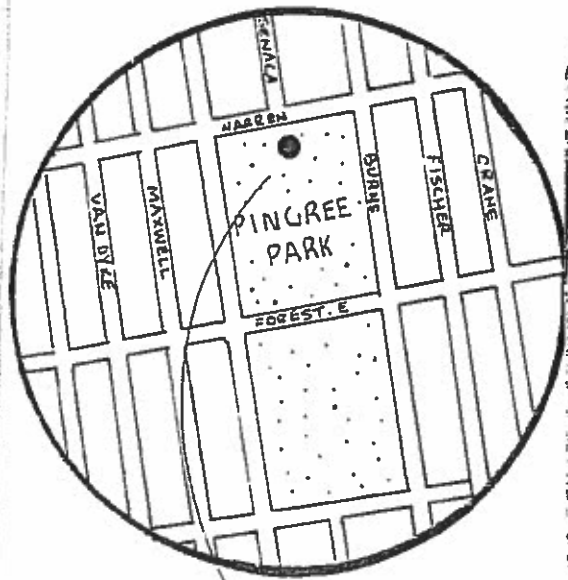

ABZ EVERYTHING IS ANYTHING



APPARITION WITH A VIEW, 1894

1984?

Location: Chene Park, southwest Dubois entrance.

Sculptor: Richard Tucker.

Biographical/
Information: 1943- . The artist resides in Manchester Michigan, and received his M.F.A. from Eastern Michigan University in 1981.

Material/
Technique: Concrete and plexiglass.

Size: 2' 6" x 3' x 11'.

Description: A tall concrete column supports a balanced rock. In the upper quarter, a rectangular opening pierces the hollow structure. This opening is covered with two pieces of red plexi glass.

This work was originally part of a sculpture show entitled Installations/Outdoor Sites, May 26-June 23, 1984, organized by Detroit Focus Gallery, curated by Al Hebert, and supported by the Michigan Foundation for the Arts, the National Foundation for the Arts, and the Detroit Council for the Arts. The exhibition was the opening introduction to the Detroit Recreation Department's Chene Park, the first of three linked parks along the near east riverfront area of the City. In collaboration with the park's architect, David Schervish, the Recreation Department selected five works from the show's twenty which they considered to be among the best for relocation at the Chene Park Site. From this group, three were later purchased by the City.

Inscription: None.

Important
Historical
Facts: --N/A.

Department
Responsible
for
Maintenance: Detroit Recreation Department.

Condition: In accordance with report filed by
Richard G. Hautau, Chief of Landscape
Architecture, red plexi-glass on river-
side is broken.

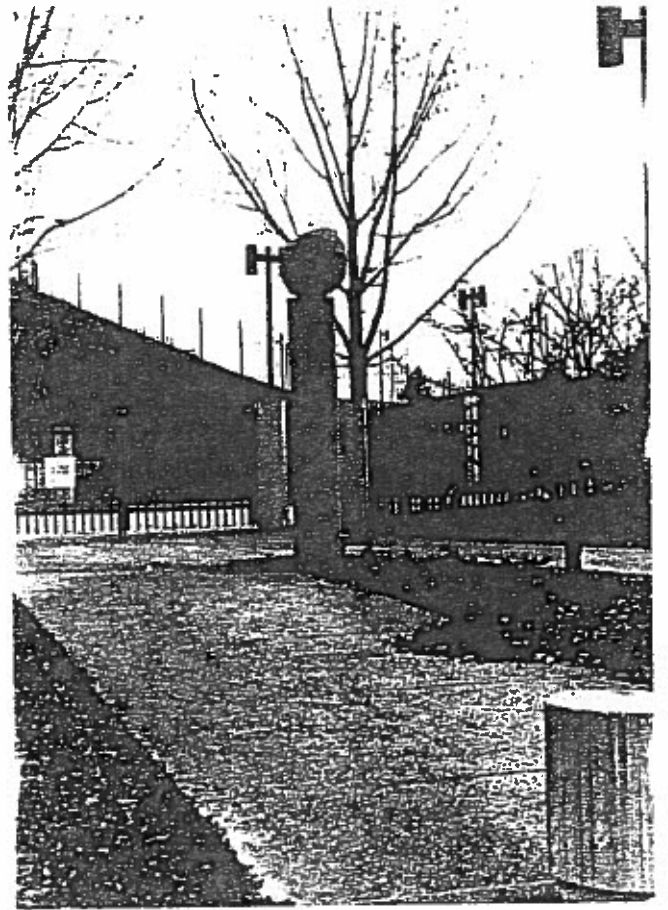
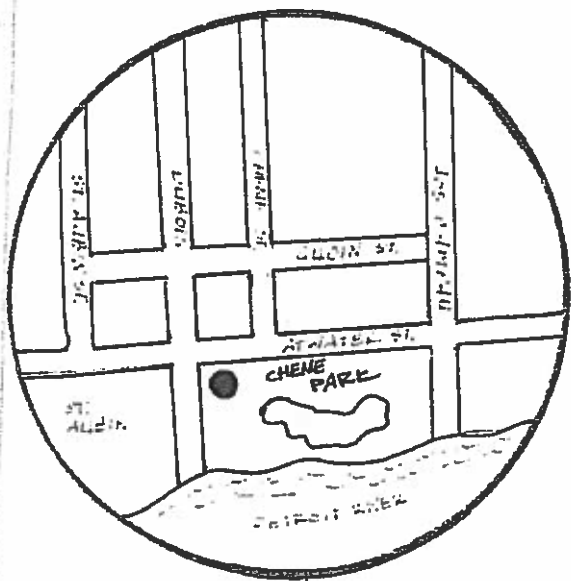

APPARATION WITH A VIEW, 1894



ASCENSION

Location: Palmer Park, Merrill Plaisance entrance.

Sculptor: Barry Lehr.

Biographical/
Information: 1951- . After attending graduate school in art at the University of Michigan, Lehr moved to Philadelphia to pursue employment opportunities.

Material/
Technique: Welded and painted steel.

Size:

Description: "This vivid yellow construction...rises like a beacon on a site just west of the main parking lot of Palmer Park. The sculpture is composed of three curved hollow steel slabs of the same basic shape, but turned, or rotated, and stacked at slightly different angles one from the other."

Taken from Art in Detroit Public Places,
by Dennis Nawrocki, Wayne State
University Press, 1981.

Inscription:

Important
Historical
Facts:

--Selected by the Palmer Park Citizens
Action Council, Ascension was funded
by the Detroit Recreation Department.
--Dedicated, August, 1977.

--Artist's statement: "I am very pleased to have this opportunity to work with the City of Detroit in making positive statements toward the revitalization of culture in our environments. Programs such as these sponsored by the national, state and local arts councils provide mutually rewarding situations for both artists and communities."

Department
Responsible
for
Maintenance:

Detroit Recreation Department.

Condition:

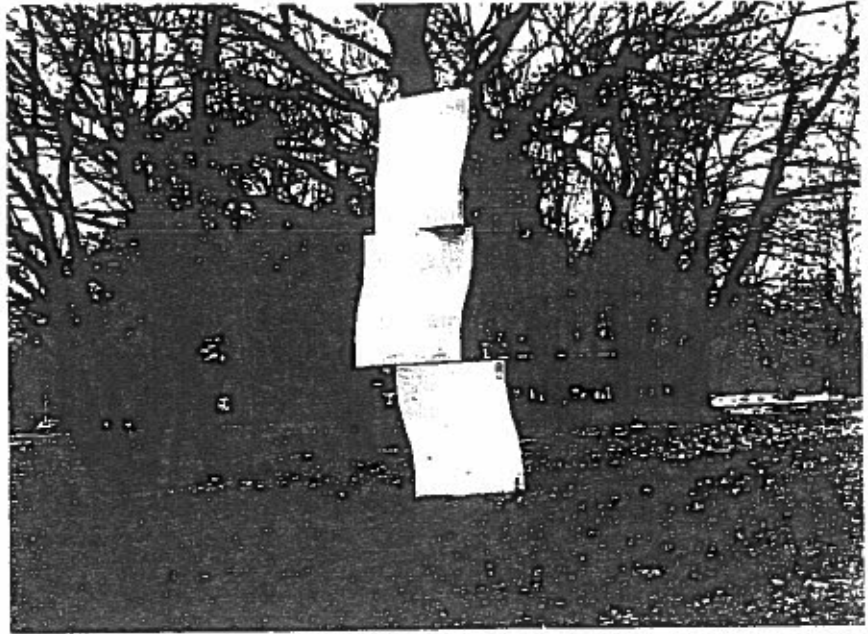
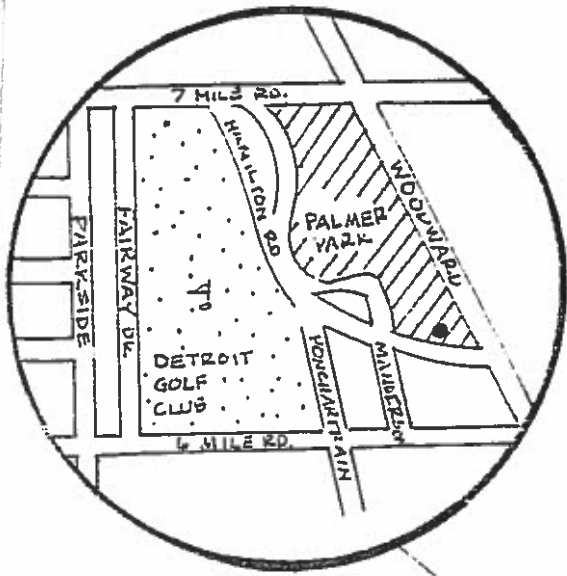

ASCENSION
PALMER PARK



BED OF BOATS

Location: St. Aubin Park & Marina

Sculptor: Vito Acconi with Brownie Johnson,
Matthew Pickner & Luis Vera.

**Biographical
Information:** None.

Material: Concrete.

Description: The concrete perimeter of a buried dry dock, a pit in front of the marina building, is used as the ground for concrete boats: the boats emerge from the concrete, it's as if the boats are born out of the concrete.

Condition: Good.

**Department
responsible
for maintenance:** Detroit Recreation Department.

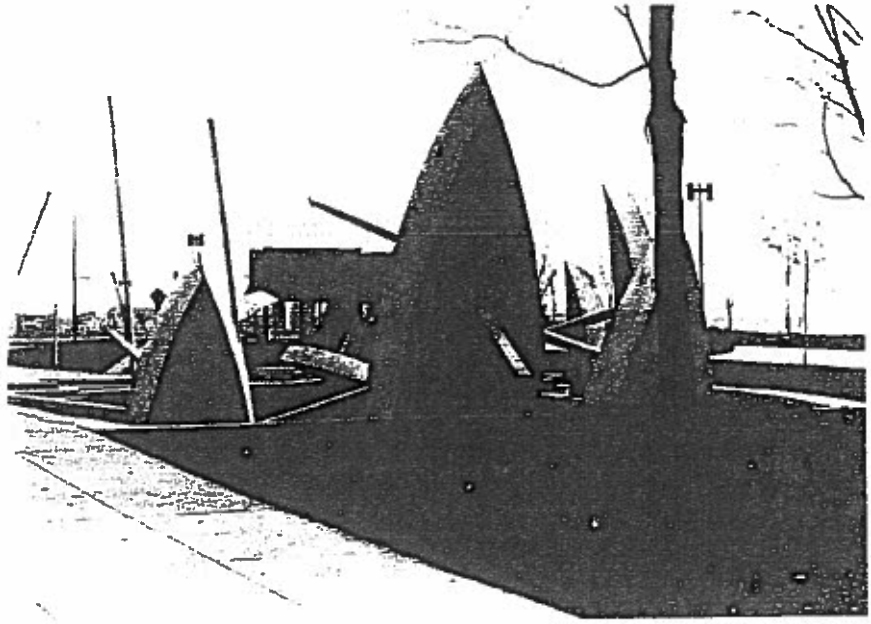
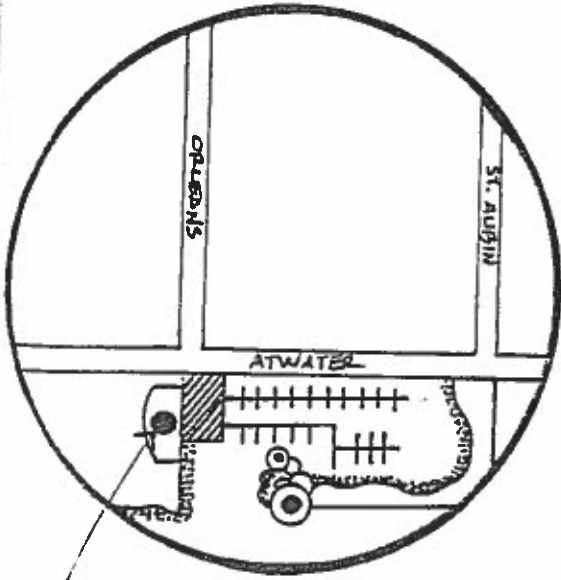

BED OF BOATS - ST. AUBIN PARK



CARNIVAL, 1984

Location: Chene Park, end of Chene Street at Riverfront Plaza.

Sculptor: John Piet.

Biographical/
Information: 1946- . The artist resides in Detroit, Michigan, received his M.F.A. from Wayne State University and presently teaches at Macomb County Community College (1984).

Material/
Technique: Polychrome steel.

Size: 18' x 30' (approximate).

Description: Three separate constructions are arranged in a semi-circle, two are light and airy, the third one consists of solid planes. All repeat a motif of angles, circles, or semi-circles, and are painted the same dusty color hues of the surrounding environment.

Inscription: None.

Important
Historical
Facts: --The work was originally part of a sculpture show entitled Installations/Outdoor Sites, May 26-June 23, 1984, organized by the Michigan Foundation for the Arts, the National Foundation for the Arts, Michigan Council for the Arts, and the Detroit Council for the Arts. The exhibition was the opening introduction to the Detroit

Recreation Department's Chene Park, the first of three linked parks along the near-east riverfront area of the city. In collaboration with the park's architect, David Schervish, the Detroit Recreation Department selected five works from the show's twenty which they considered to be among the best for relocation at the Chene Park site. From this group, three were later purchased by the City.

Department
Responsible
for
Maintenance:

Detroit Recreation Department.

Condition:

Condition: good. 9/878 needs repainting. Southern piece of footing is loose and needs to be replaced.

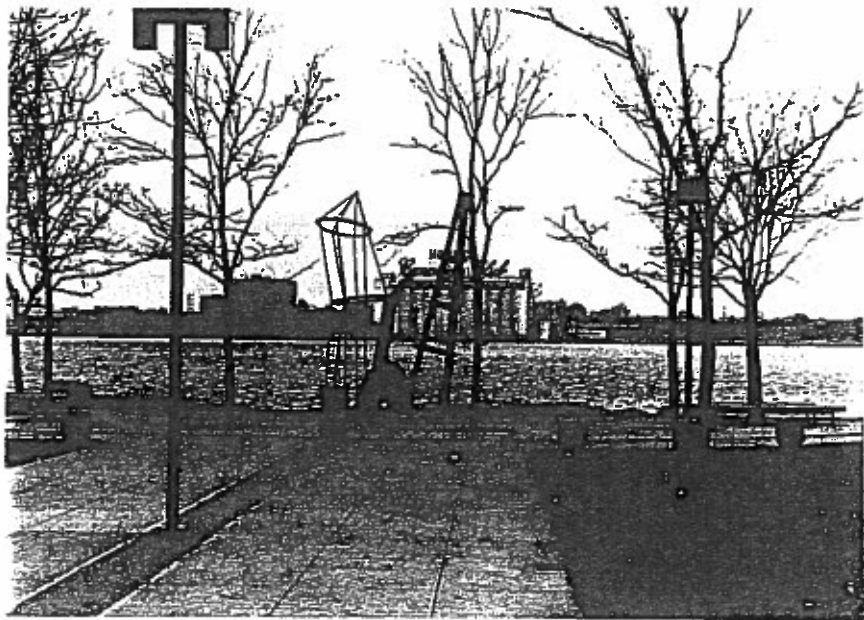
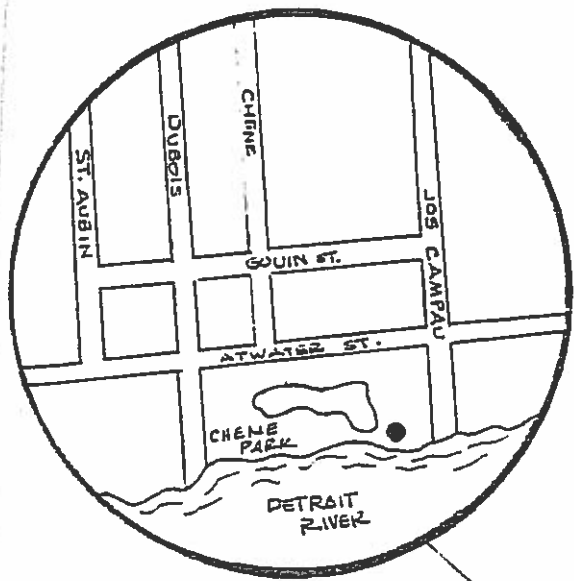

CARNIVAL, 1894

CHENE PARK



CATCHING UP

Location: Grand Circus Station of the People Mover, upper level passenger platform.

Sculptor: Jay Stewart Johnson.

Biographical Information: Johnson was born in New York City and has his studio in Mercerville, New Jersey. He is best known for his bronze figures.

Material/Technique: Cast bronze with a medium brown patina.

Size: Lifesize.

Description: Man standing reading newspaper with suitcase and another newspaper resting on the suitcase.

Inscription: None.

Important Historical Facts: --Detroit's Catching Up is one of six identical pieces cast, however, Detroit's is personalized in that the man is reading "The Detroit News," and on his suitcase sits the "Detroit Free Press."
--The figure cost \$38,000.
--The People Mover opened July of 1987, and Catching up was dedicated on the opening.

Department Responsible for Maintenance: Detroit Transportation Corporation.

Condition: Excellent.

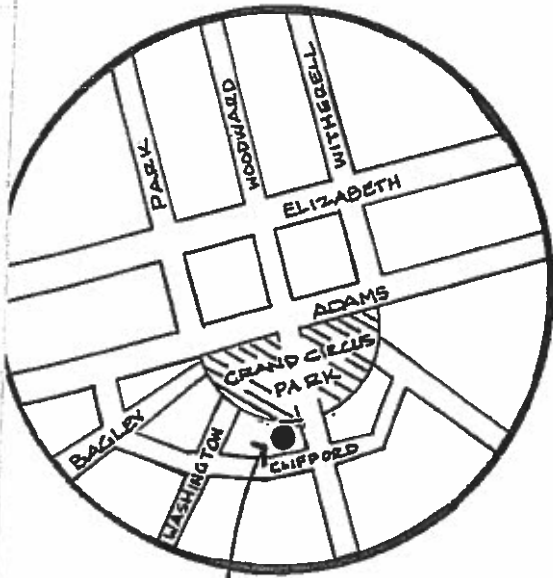

"CATCHING UP" STATUE
- PEOPLE MOVER STATION ART -



. CENTURY OF LIGHT

Location: Washington Boulevard at Grand River Avenue.

Sculptor: Jim Pallas.

Biographical/
Information: Pallas received both his B.F.A. and M.F.A. from Wayne State University. His studies ending there in 1965. A native Detroiter, he still resides in the area and teaches at Macomb County Community College. In 1968, he began his involvement with electronic sculptures, which have given him national acclaim.

Material/
Technique: This multi-media work incorporates a computer, 144 lights, radar, a microphone, and a photo-cell for input information. The Detroit Building Authority has extensive information on its construction and along with the artist examine the work quarterly.

Size: The height is approximately 20 feet. The top of the structure spans 18 feet.

Description: On a tall, slim, steel pole base, Century of Light stands in a shallow round pond like a umbrella or tree. At the top, ribs or branches of interlocking red steel support the 144 large glass globes which respond to motion and sound with the help of radar and computer stationed nearby.

Inscription: None.

Important
Historical
Facts:

- In late 1979, Gino Rosetti, architect of Washington Boulevard five block steel frame, together with Detroit Businessman Tom Schoenith, then President of Detroit Electrical Association, commissioned the work after a competition with other artist. Designed to aesthetically blend with the steel frame structure, the sculpture is located near the rim of the canopy where water forms a curtain and falls into a reflecting pool.
- Worth approximately \$100,000, Century of Light was donated to the City by member firms of the Eastern Michigan Electrical Association, and commemorated the 100th Anniversary of Thomas Alva Edison's invention of the light bulb in 1880.
- A champagne reception on July 2, 1980, celebrated the official operation of Century of Light.
- In the summer months of 1980, the sensitive microphones caused the work to light up constantly, so in order to stop the overload, Jim Pallas unplugged the sculpture's ears, leaving it to operate by light and motion alone.

Department
Responsible
for
Maintenance:

Detroit Building Authority.

Condition:

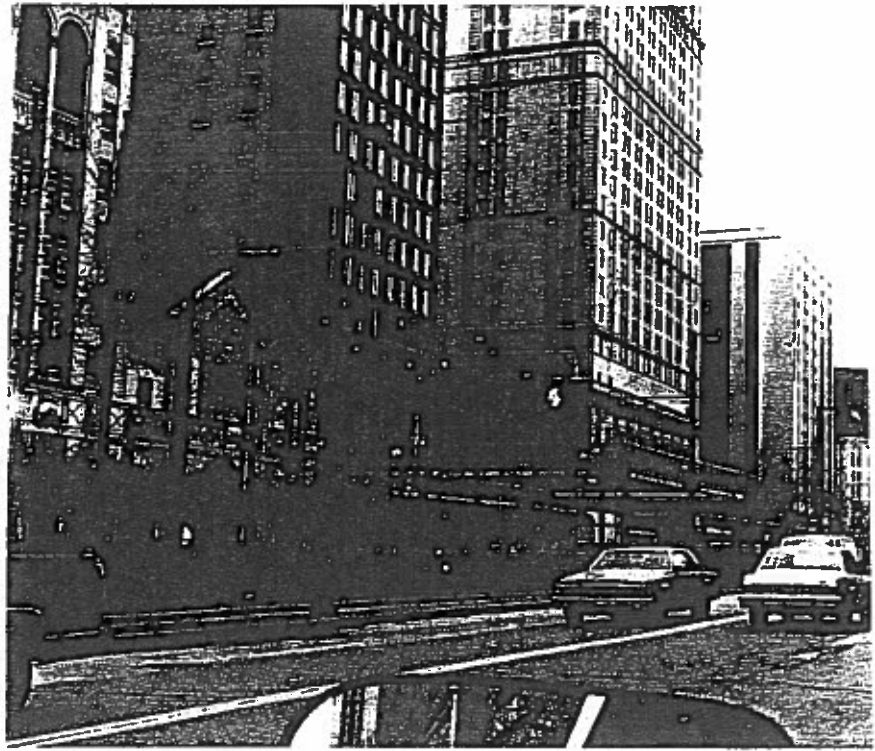
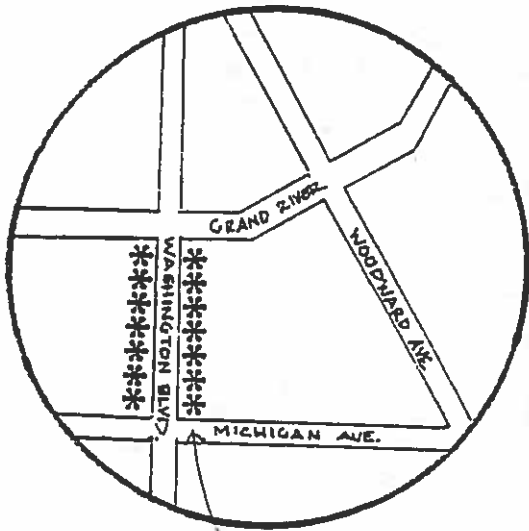

CENTURY OF LIGHTS



CONTINUITY TOWER
(Jackie Feigenson Commemorative Sculpture)

Location: East of 3rd & Grand Blvd.

Sculptor: Robert Sestok.

Biographical Information: None.

Material: Corten steel.

Description: 12 foot corten steel open tower.

Inscription: "To the memory of Jacqueline Feigenson who saw most clearly that art begins with artists.

Condition: Good.

Department responsible for maintenance: Detroit Recreation Department.

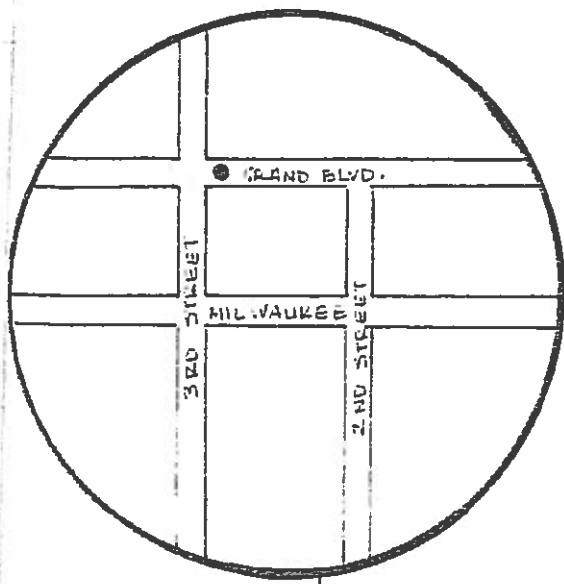

CONTINUITY TOWER



THE ENTRANCE

Location: West Grand Circus Park.

Sculptor: John Piet.

Biographical/
Information: 1946- . The artist resides in Detroit, Michigan; received his M.F.A. from Wayne State University and presently teaches at Macomb County Community College (1984).

Material/
Technique: The hallow fabricated sheet steel structure is painted a bright orange-red.

Size: 22 feet high, 5 feet wide, 4 feet deep.

Description: From its triangular-like base, the abstract "figure" rises with a slight curve and is topped with fan-like appendages. Five bars across the bottom represent the continents participating in the International Theater Olympiad (see Important Historical Facts).

Inscription:

Important
Historical
Facts: --Entrance was commissioned as a salute to the International Theater Olympiad, the first sanctioned amateur theater festival in the United States and a feature of Detroit's 1975 Bicentennial celebration. In June during the theater festival more than 500 performers from 40 countries participated in and attended a number of scheduled performances in the Detroit area.

- John Piet said the following concerning his sculpture. "The Entrance symbolizes a certain freedom we all have to enter, a new direction, a new era, new thoughts and new life. It stretches upward, poised in that expectant moment that precedes a move. As a Bicentennial sculpture, it is a reminder to Detroit to keep its doors open to people and new ideas as we enter a new era."
- The work was commissioned for Detroit by Peoples Art: 200 Minus One, a Bicentennial project jointly sponsored by the Recreation Department, Michigan Council for the Arts, and the Central Business District Association., Jury members of the competition held in 1975, were John H. Neff, Mary Denison, Henri Umbaji King, and two members of the community. Funding came from the Michigan Council for the Arts, and the National Endowment for Arts. Much of the steel was supplied by the Kendall Company and ABC Roll Company. Fabrication and special equipment came from Werden Industries and Wer-Co Fabrication Company.
- Dedication ceremonies were held on Sunday, June 22, 1975, with Leon Atchison, director of Detroit Recreation Department, officiating.
- In 1984, in conjunction with the re-dedication of the newly restored Edison Fountain; Entrance was repainted.

Department
Responsible
for
Maintenance:

Detroit Recreation Department.

Condition:

Good.

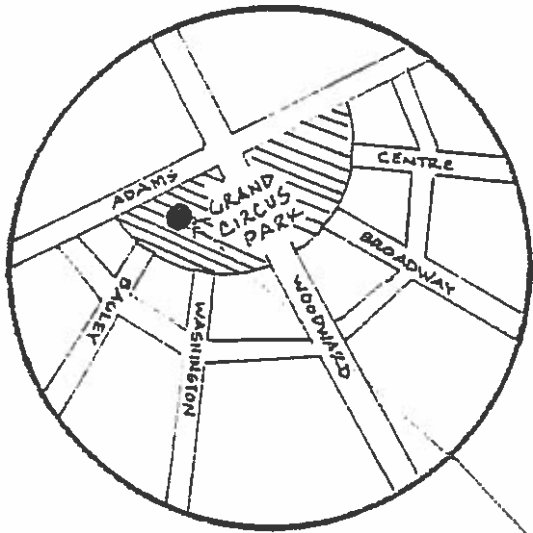

THE ENTRANCE
GRAND CIRCUS PARK



EXPLORATION

Location: Outside Explorers Room, Children's Library, Detroit Public Library (Main Branch), near Cass Avenue entrance.

Sculptor: Nicolo DeLauro.

Biographical/
Information 1916- . American.

Material/
Technique: Cast bronze, granite base.

Size: 8 feet tall with 1300 lbs. base.

Description: Dancing female figure with abstracted lyrical garment form a circular motif which is then repeated in the gesture of the right hand. The figure bends dramatically backward paralleling the ground.

Inscription: "An invitation to viewers to discover the joy of ever changing beauty produced by form, light and shadow."

Important
Historical
Facts: --Donated to library by Thomas G. Long, then Library Commissioner, in 1967.
--It was cast at Battaglia Foundries, Milan, Italy.
--Unveiled September 15, 1967.
--Value: \$10,000 plus cost of erection and base.

Department
Responsible
for
Maintenance: Detroit Public Library.

Condition: Good.

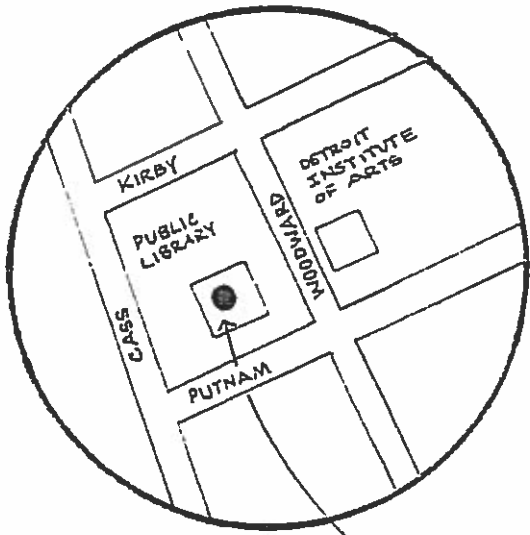
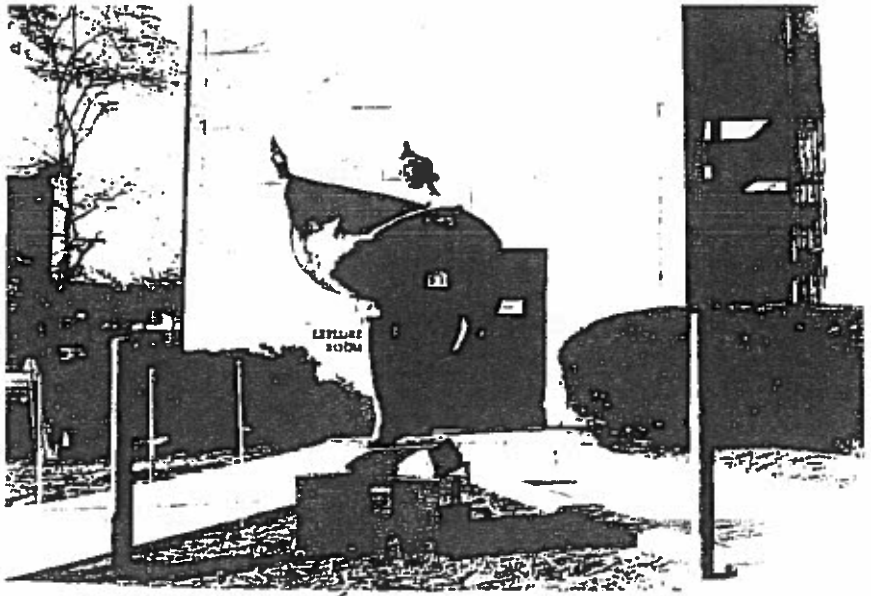

EXPLORATION - THE MAIN LIBRARY



HARD EDGE SOFT EDGE SCULPTURE

Location:

In Southeast corner of Harmonie Park,
near Centre Street.

Sculptor:

Hanna Stiebel was born in Israeli,
Stiebel now lives in Bloomfield Hills,
Michigan.

**Biographical/
Information:**

Hanna Stiebel received both primary and secondary education in Israel and obtained her Bachelor and Master of Fine Arts degrees from the Cranbrook Academy of Art, Bloomfield Hills, Michigan. She also did graduate work at the New School for Social Research in New York and at the University of Florence, Italy. She has served for two years as head of the Art Department of Roeper City and Country School in Bloomfield Hills, Michigan. Once a dancer in the Martha Graham troupe, Stiebel sees a close relationship between her career in sculpture and her background in dancing: "One begins by combining all forms of art and movement, as found in music in my case a carryover from dancing." The works which have evolved since her army/resistance days in Israel are many-sided, yet with a familiar flavor to them. There is an essence of Henry Moore present there somewhere, as the artist herself agrees. Her admiration for Moore is great, yet she will admit in the same breath that "her work is her own, beginning always with a concept, or a theme."

To date, she has exhibited at the Detroit Institute of Arts; Somerset Mall Gallery, Troy; Cranbrook Museum of Art, Bloomfield; London Arts Gallery, Detroit; Reflections Gallery, Atlanta, Georgia; and the University of Michigan

at Dearborn, Michigan. She has received commissions from Alsar Aluminum Company, Detroit Bank of Commonwealth, Detroit; Art Camp, Lake Fairlee, Vermont; and the Detroit Recreation Department as well as other private commissions.

Material/
Technique:

Aluminum casting.

Size:

9-foot high aluminum casting with 2 knife-like patterns repeated 3 times on the casting which is set in a circular aluminum base plate, and mounted on a 2'-6" high circular concrete base.

Description:

Inscription:

None.

Important
Historical
Facts:

- \$2,800 gift from the New Detroit, Inc. subcommittee "Art for Living" was awarded to the Detroit Recreation Department for placement in Harmonie Park. Placement site suggested by the Artist. Accepted and adopted, J.C.C. 11-8-1972, page 2763.
- On April 18, 1973, concrete base poured and sculpture mounted on the base by a Forestry crew of the Detroit Recreation Department.

Department
Responsible
for
Maintenance:

Detroit Recreation Department.

Condition:

Poor.

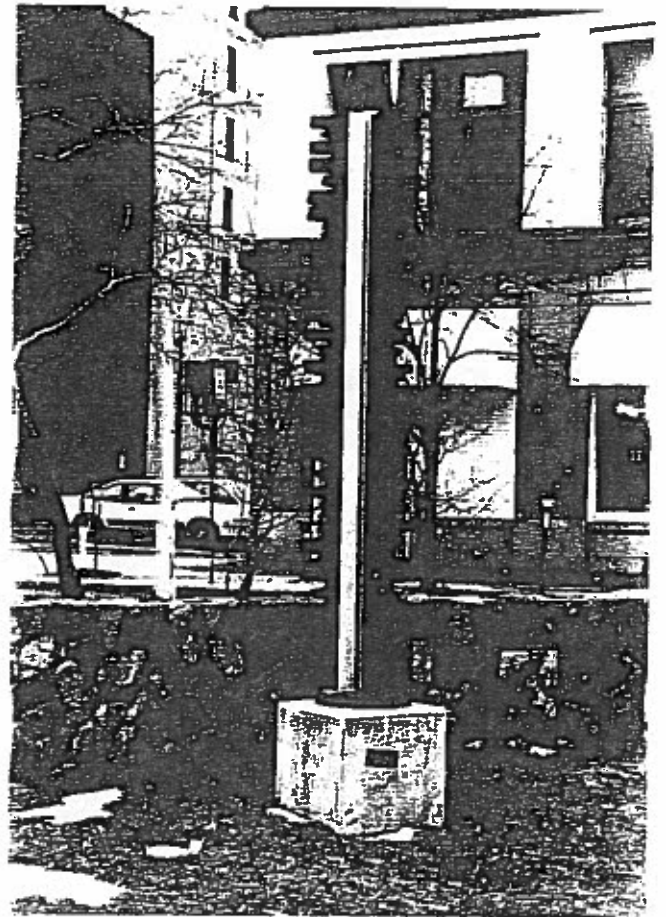
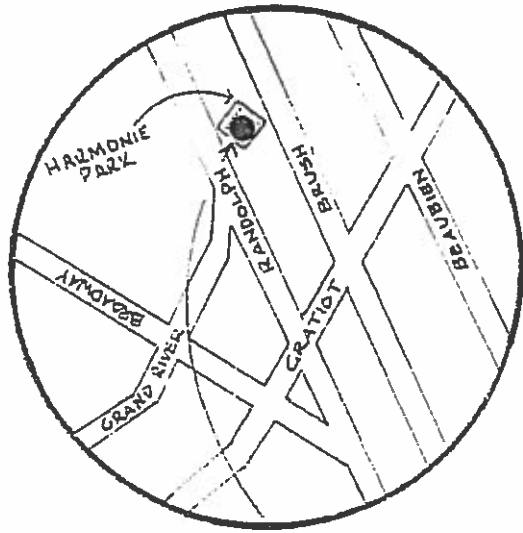

HARD EDGE SOFT EDGE
SCULPTURE



LATTICE FORM, 1984

Location: Chene Park (near park pavilion).

Sculptor: Raymond L. Katz.

Biographical/
Information: 1938- . Katz was born in Detroit, received his M.F.A. from Wayne State University in 1968, and now works in Pontiac.

Material/
Technique: Steel.

Size: 9 1/2' (height) x 10' (diameter).

Description: The white semi-circular sculpture echos the cylinder shapes of the pavilion of which it seems a part. The lattice construction allows the viewer to look through the work at a filigree of trees and the river.

Inscription:

Important
Historical
Facts:

--This work was originally part of a sculpture show entitled Installations/Outdoors Sites, May 26-June 23, 1984, organized by Detroit Focus Gallery, curated by artist Al Hebert, and supported by the Michigan Foundation for the Arts, the National Foundation for the Arts, the Michigan Council for the Arts, and the Detroit Council for the Arts. The exhibition was the opening introduction to the Detroit Recreation Department's Chene Park, the first of three linked parks along the near-east riverfront area of the city. In collaboration with the park's architect, David Schervish, the Detroit Recreation Department selected

five works from the twenty projects originally contained in the said showing which they considered to be amongst the best for relocation at the Chene Park site. From this group, three were later purchased by the City.

--Artist's statement: "An intimate place to contemplate the beauty of the curve of patterned shadows cast across the ground. Light flickering through a multitude of shapes revealing the beauty of the natural and man-made environment through the intimacy of space and place. A dialogue of otic and kinetic relationships joining the functional and esthetic into feelings of completeness.

Department
Responsible
for
Maintenance:

Detroit Recreation Department.

Condition:

Good.

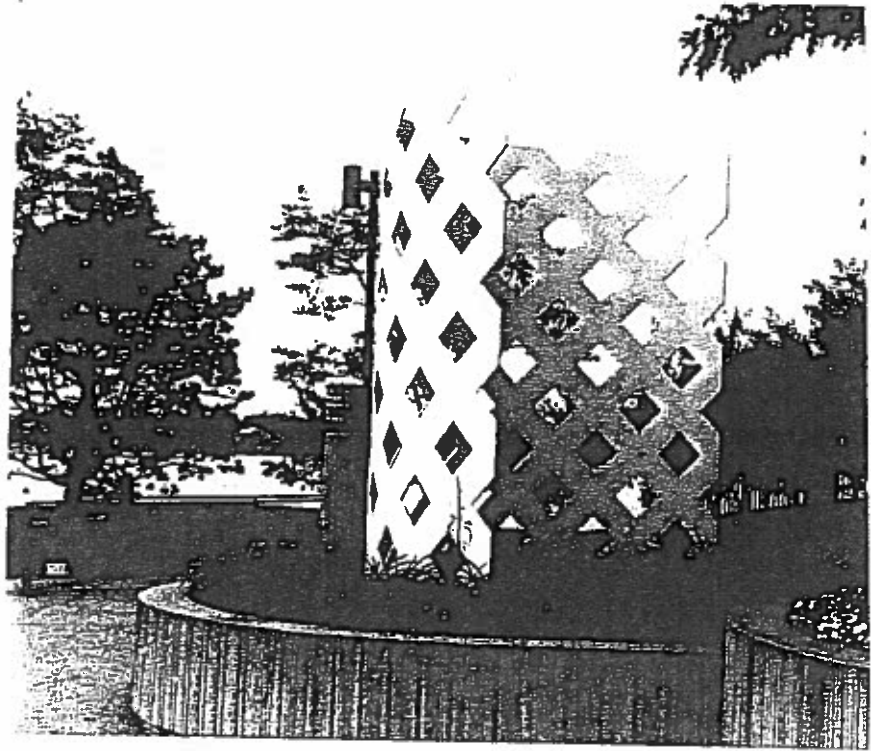
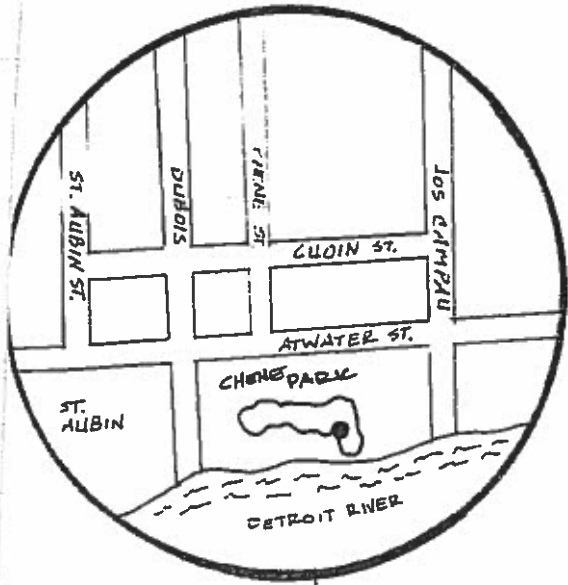

LATTICE FORM



PINK LANDSCAPE---THREE TRUSSES PLUS

Location: Cass Park, Second Avenue at Ledyard Street.

Sculptor: James Lawton.

Biographical Information: 1944- . Born in Kentucky, Lawton received his B.A. from Murray State University, Kentucky, and his M.F.A. from Kent State University, Ohio. He has exhibited widely, especially in the state of Michigan. He presently teaches at Michigan State University.

Material/
Technique: Welded and painted steel.

Size:

Description: Three pink parallel tubes ascend vertically and then descend at an approximate 60° angle. Narrow, more delicate tubes intercept the trio, adding more shapes and angles, creating a new dimension in terms of movement and space.

Inscription: None.

Important Historical Facts: --This work was commissioned for Detroit in 1978, by People's Art Project: 200 Minus One; a program created in celebration of the Bicentennial of the Michigan Council of the Arts and in preparation for the Nation's Bicentennial Celebration. Jury members in the competition, which was held in 1975, included Mary Denison,

Henrik Umbaji King, and community members Bill Curry and Pauline Manhushe. Pink Landscape replaced an earlier work selected by the jury entitled Rabbit, by Michael Luchs. --After a petition from the Cass Park community called the work "unsafe and unsightly" Rabbit was unfortunately dismantled, stored, and eventually destroyed.

Department
Responsible
for
Maintenance:

Detroit Recreation Department.

Condition:

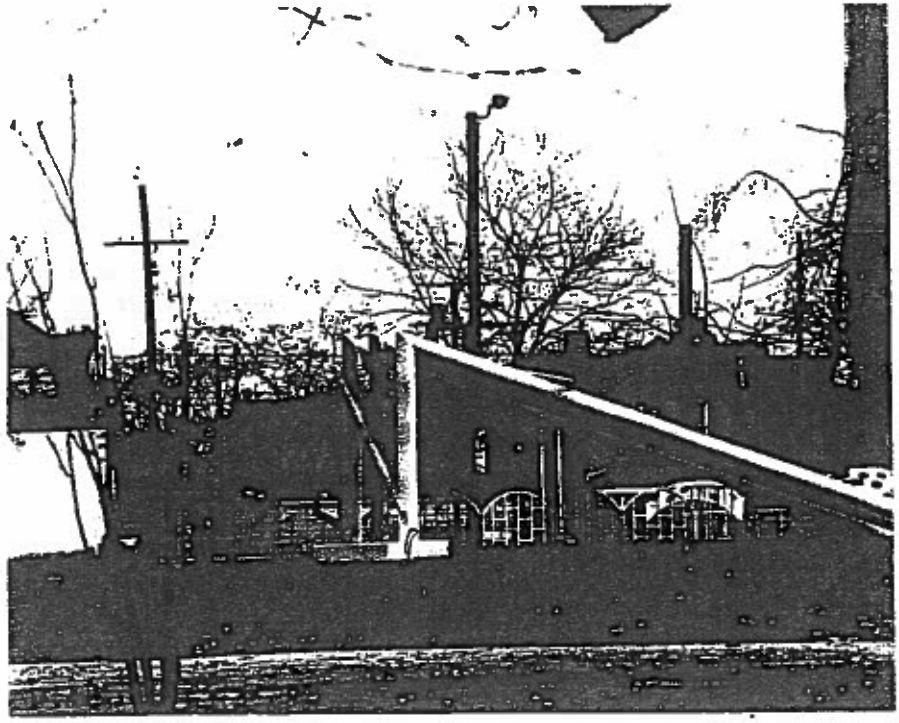
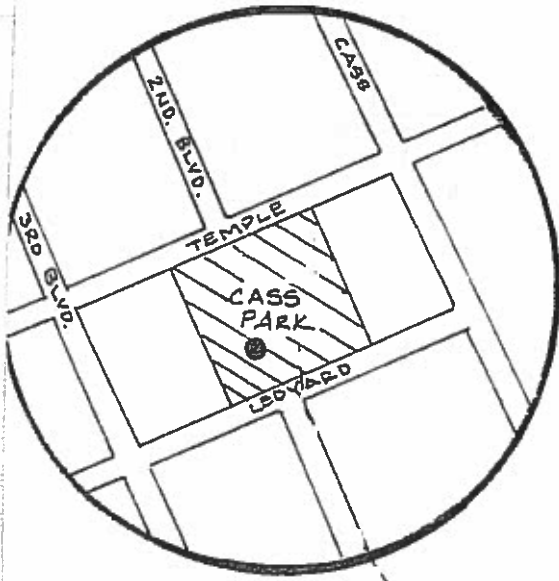

PINK LANDSCAPE
THREE TRUSSES PLUS



PYLON

- Location:** Philip A. Hart Civic Center Plaza, located at Woodward Avenue and Jefferson Avenue.
- Sculptor:** Isamu Noguchi.
- Biographical/
Information:** Born in 1904, in Los Angeles, California, Isamu Noguchi has achieved international fame and recognition. His mother was American, his father Japanese, and as a result, Noguchi's work relates to two cultures. To this day, he works in a studio on the island of Shikoku, Japan, as well as in New York City. Although he has gained acclaim as a draftsman, stage designer of sculptural backgrounds for Martha Graham, and as an industrial designer of lamps and furniture, it is as a sculptor of monumental works that he is best known. In Noguchi's work there exists a harmony with the environment that goes back to nature itself.
- Material/
Technique:** Large Squares of quarter-inch thick aluminum plating are attached to a straight steel frame by fasteners at the end of steel arms, which direct the shape into a subtle curve. New York architect Shoji Sadoa, who worked with Noguchi on the project said "Each piece starts off as a flat sheet and then is pulled into shape by the frame. The modification is very slight so it rotates."
- Size:** 120 feet high, 7 x 7 feet square.
- Description:** A giant sectioned silver spike gently makes a quarter twist from bottom to top. Its monumentally serves to anchor and direct the viewer towards the nearby Dodge Fountain, also by Noguchi. The

two works of art and the overall design of Hart Plaza is intended to reflect and enhance the surrounding environment through texture, shape, and water. Noguchi compares his Pylon to the double helix of DNA which determines the characteristics of living things. He said, "All things tend to spiral - water and air. This is a basic thing. It's so basic it's beyond design. It's so basic, it's like a needle."

Inscription:

Important
Historical
Facts:

- Built in 1973, it was commissioned via Smith, Hinchman and Grylls Associates, Inc., architects, as a companion piece to the later built Dodge Fountain. The late auto-heiress, Anna Thompson Dodge, stipulated in her will that the fountain, for which she bequeathed two million dollars, be located at the foot of Woodward Avenue. As the Pylon is the fountain's gateway, her stipulation was satisfied.
- Total cost of \$401,000 was paid for by funds from the Detroit Capital Gifts Committee which determines how financial gifts to the City will be spent.

Department
Responsible
for
Maintenance:

Detroit Recreation Department.

Condition:

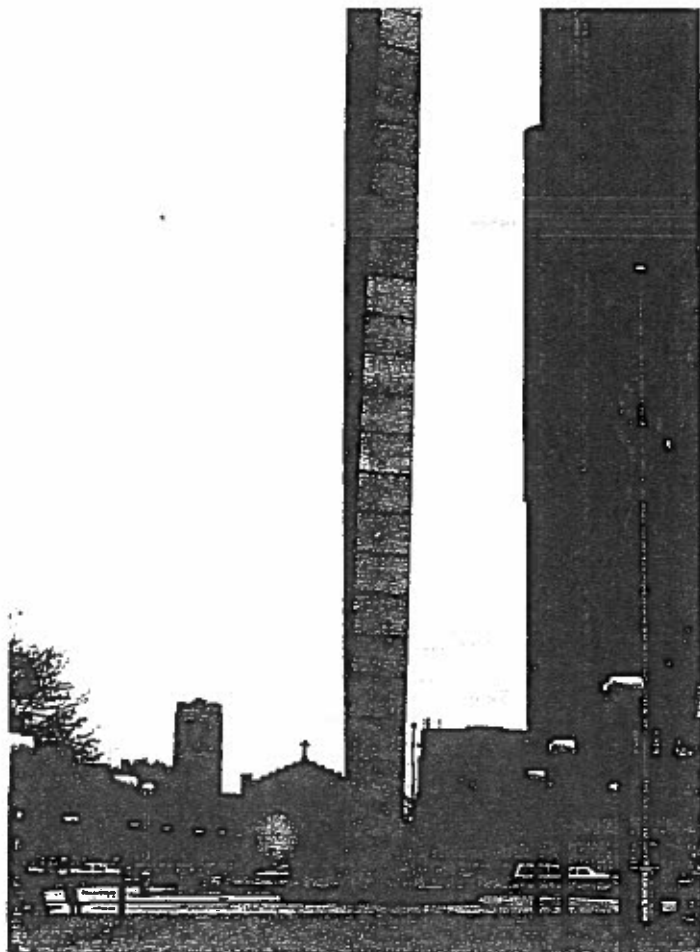
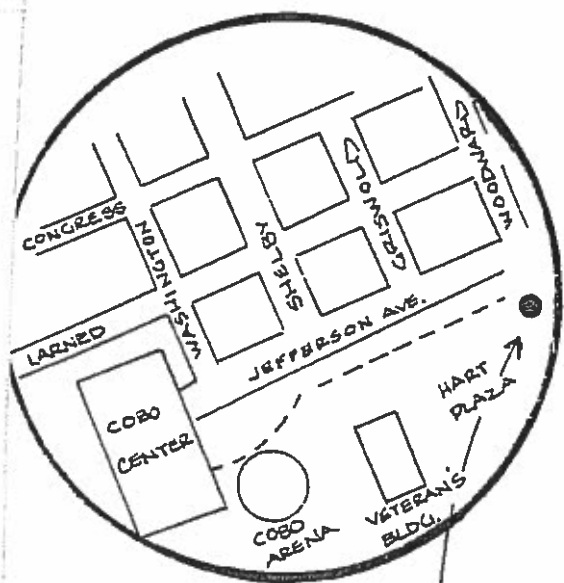

PYLON
HART PLAZA

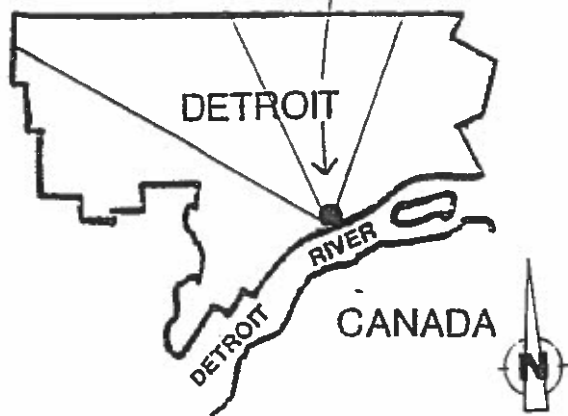

GUY O. SAULSBERRY SQUARE

Location: Warren Avenue Medical Center.

Sculptor: None.

Material: Bronze.

Description: Bronze plaque flushed with ground.

Inscription: This space is dedicated to the memory of Guy O. Saulsberry (1900 - 1978), a prominent Detroit physician who was the founder and medical director of Kirwood General Hospital and Kirwood Mental Health Center. Among many national & local honors, Dr. Saulsberry received the Physician of the Year award from the National Medical Society in 1972.

Condition: Good.

Department responsible for maintenance: Detroit Recreation Department.

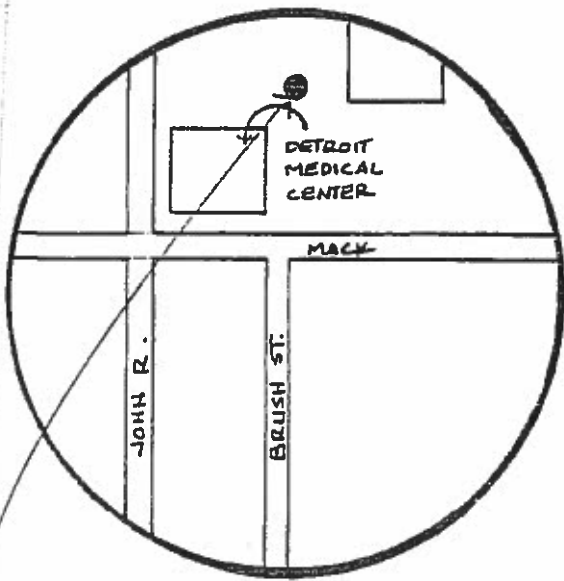

Guy O. Sausberry Square
 This space is dedicated to the memory of Guy O. Sausberry (1900-1978), a prominent Detroit physician who was the founder and medical director of Kirwood General Hospital and Kirwood Mental Health Center. Among many national and local honors, Dr. Sausberry received the Physician of the Year Award from the Detroit Medical Society in 1968 and the General Practitioner of the Year Award from the National Medical Society in 1972.

GUY J. SAULSBERRY SQUARE



SENTINEL

Location: Capitol Park.

Sculptor: Morris Brose.

Biographical/
Information:

Born in 1914, in Wyszkow, Poland, Morris Brose apprenticed as a watchmaker and studied acting. Emigrating to the Detroit area in 1921. Before then he made furniture and studied literature and art. In the late 40's, he pursued his interest in art at Arts and Crafts (now called Center for Creative Studies) in Detroit, Wayne State University, and Cranbrook Academy of Art. He has since exhibited and worked internationally as his success has brought him numerous awards. His teaching credits include Oakland University, Center for Creative Studies, and Cranbrook Academy of Art.

Material/
Technique:
Size:

Welded corten steel.
14 x 5 x 4.

Description:

Sentinel, a construction of geometric shapes and planes, hovers over its park site like a protecting angel. The abstracted form confronts, but is also friendly. As the park is a location where viewers quickly pass by, the artist wanted to suggest something recognizable, thus, he alluded to the human form. Rising out of its base like a spike, Sentinel's multiple planes become a spine, a belly, and fluttering wings, while relating to the rectangular buildings of the area. The title refers to one who watches over; however, it is not intended to represent a militaristic guard, but rather to evoke a safe, an comfortable feeling. The material chosen, corten steel, is never eaten away by rust and becomes richer in color

with time. Rain water changes and refreshes it, so that the natural cleansing process becomes a metaphor to the city, reflecting the cycle of decay and rejuvenation.

Inscription: None.

Important
Historical
Facts:

- The Detroit Council for the Arts invited Morris Brose to sculpt a work specifically for this location. The dedication ceremony was held on October 12, 1979.
- Sentinel I and Sentinel II, are smaller works reflecting a similar concept and are held in a private collections in Toledo, Ohio, and on the Wayne State University campus in Detroit, Michigan, respectfully.

Department
Responsible
for
Maintenance:

Detroit Recreation Department.

Condition: Good.

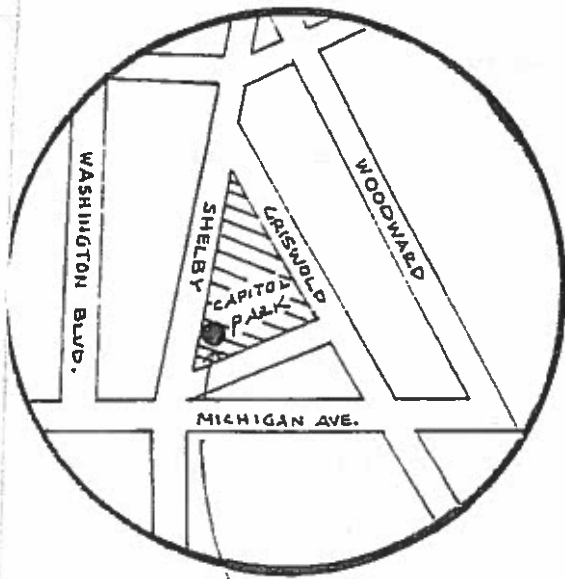

SENTINEL
(CAPITOL PARK)



STANDING TOGETHER

Location: Washington Boulevard and Clifford Street.

Sculptor: Marcia Wood.

Biographical/
Information: 1933 -
Born in Paw Paw, Michigan, Wood was educated at Kalamazoo College, Cranbrook Academy, Courtland Institute Art, University of London, and Harvard University. She has exhibited widely and possesses the following teaching credits: Hope College, 1958-63, Philadelphia College of Art, 1963-65, and Kalamazoo College to present. Wood is a Cranbrook trained artist. Fine Arts Professor at Kalamazoo College since 1965.

Material/
Technique: Brushed stainless steel.

Size: 12 feet by 8 feet by 4 feet, 3,000 pounds.

Description: Seven vertical stands of brushed stainless steel tubes suggest human forms. Two horizontal bars of metal near the top imply arms reaching from shoulder to shoulder in gestures of intimate friendship.

Inscription: (on the bronze plaque on top of round cement base)

Standing Together
Marcia Wood - 1980
Fabricators: David Volosky
Leon Hillman
Kalamazoo

Important
Historical
Facts:

- June, 1980, Marcia Wood's small-scale model design done in aluminum was chosen in a state-wide competition sponsored by the Detroit Council of the Arts and the National Endowment for the Arts.
- Wood's small model was fabricated into the full size form by two Kalamazoo men: David Volosky and Leon Hilman. In June 1980, the 12-feet by 8 feet by 4 feet, 3,000 pounds sculpture, entitled "Standing Together" was put in place on a round cement base by City workers.
- It was put in place on June, 1980, as part of the development of the Washington Boulevard Mall.
- Cost: \$17,500.00.

Department
Responsible
for
Maintenance:

Condition:

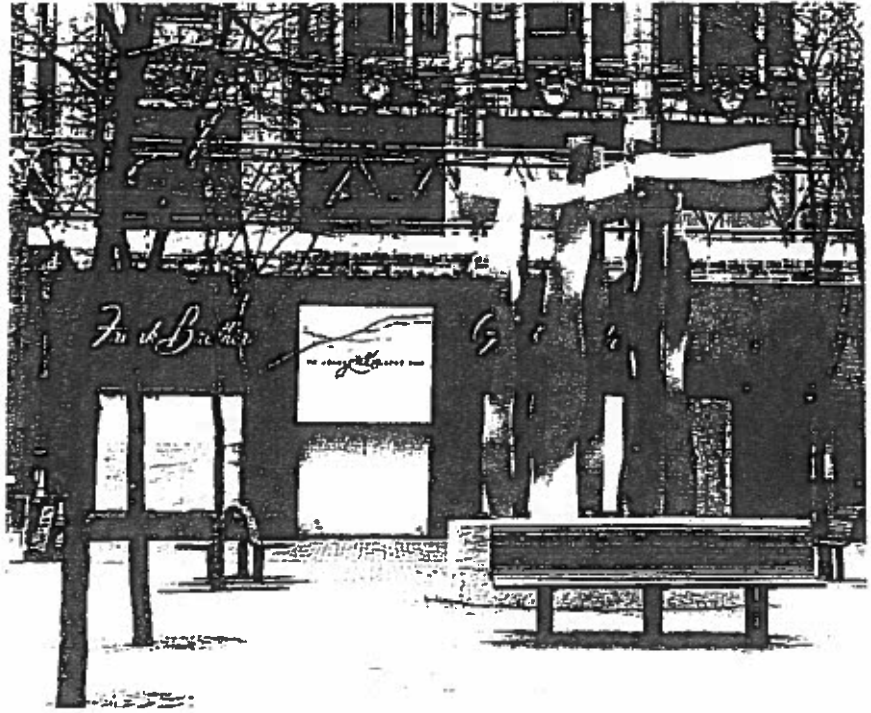

STANDING TOGETHER.

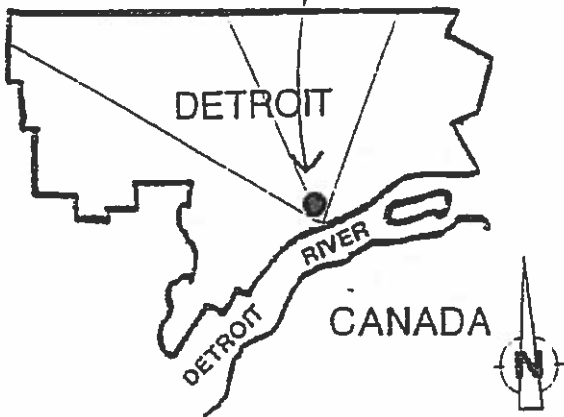

STEADY

- Location:** North side of Clark Park, bounded by Vernor Highway, Clark and Scotten Streets.
- Sculptor:** Michael Hall.
- Biographical/
Information:** Michael Hall was born in Upland, California in 1941. He received his B.A. in sculpture from the University of North Carolina in 1962, and in 1964, he obtained his M.F.A. from the University of Washington. He has since taught at the Universities of Washington, Colorado and Kentucky and since 1970, has been resident sculptor at Cranbrook Academy of Art. The recipient of numerous awards, grants, and commissions. Hall also has an impressive list of group and one-man exhibitions to his credit. He has received national acclaim and has been cited in a number of publications.
- Material/
Technique:** 7" steel pipes and 7" 90⁰ steel elbows are welded together, fastened at top with steel bolts, and painted yellow. The color has faded to an ochre.
- Size:** Approximately 13 feet high, it spans some 25 feet. Weight - approximately 1200 lbs.
- Description:** The steel pipes placed equa-distantly about 25 feet apart in a tripod-like manner, coming together at a height of approximately 13 feet. The ochre-colored pipes were altered to wave just over half way up. As a result, the structure which alludes to a pyramid take on both the geometry and organic nature of its environment.

Inscription:

Important
Historical
Facts:

- Constructed in Kentucky in 1969, Steady has been exhibited at both the University of Kentucky and Duke University, North Carolina, before finding its place in Detroit.
- Steady was donated to the City of Detroit by the Art for Living program under New Detroit, Inc. in July, 1972. The purpose of the Art for Living Program was to turn Detroit into a "city of art" through strategically placed murals and sculpture. Rather than concentrating on the Civic Center, New Detroit, Inc. wanted to stimulate neighborhoods, provide a showcase for local artists, and in so doing, install pride. The Art for Living organization remained active for two years.
- After being paid \$1,800 by New Detroit, Inc., Michael Hall transported and installed the work himself.

Department
Responsible
for
Maintenance:

Detroit Recreation Department.

Condition:

Needs painting to inhibit rust.

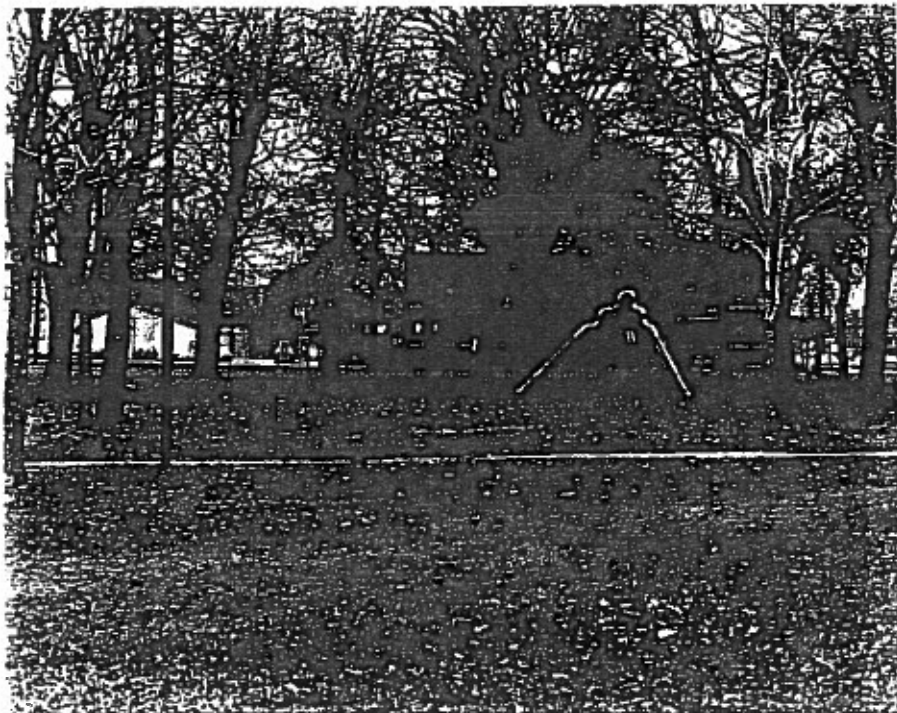
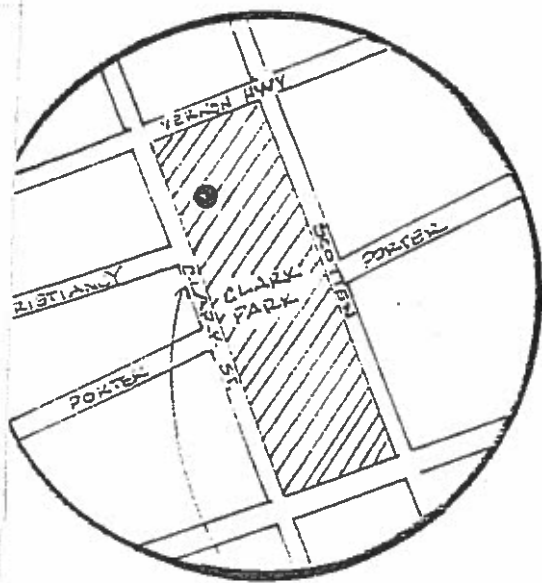

STEADY-CLARK PARK



SUNDIAL
(Sometimes referred to as the Armillary Sphere)

Location: In Memorial Park at East Jefferson Avenue and Crane.

Sculptor: Kenneth Lynch and Sons
Mr. Kenneth Lynch, Sr., President
The Craft Center Building
78 Danbury Road
Wilton, Connecticut 06897
Phone: (203) 762-8363
Designer: Mr. Andrew Crowell, Senior Designer, Kenneth Lynch and Sons

Biographical/
Information:

Material/
Technique: Constructed of wrought iron.

Size: It is six feet in diameter. The wrought iron Armillary Sphere is very heavy. Concrete footings for sphere is 36" in diameter.

Description: Sundial is set back into the park approximately 200 feet from East Jefferson Avenue. Placed in the center of a 40' circular sitting area and is the main feature of the area.

Inscription:

Important
Historical
Facts: --Armillary Sphere was installed in January of 1970, which completed the feature area.
--\$7,000.00 for Armillary Sphere;
\$450.00 for concrete footings for the sphere's base core.

--Part of Contract #41373, File #2326,
walk construction and related work,
Memorial Park.
--Total contract price: \$60,000.
--Date completed 6-16-1970 (J.C.C.
6-16-1970, pages 1524-1525.
--Contractor: Barthel Contracting
Company
21095 Halsted Road
Northville, Michigan 48167
Lee Barthel, President
Phone: Greenleaf 6-0702.

Department
Responsible
for
Maintenance:

Detroit Recreation Department.

Condition:

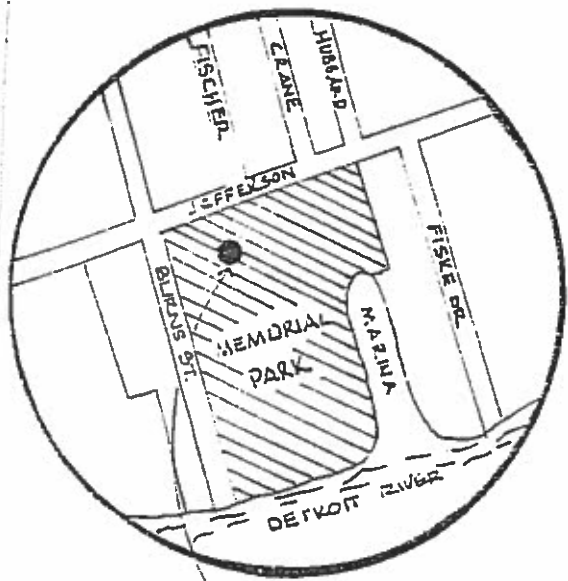

SUNDIAL MEMORIAL PARK



UNITED FOUNDATION TORCH

Location: Foot of Woodward and Jefferson Avenues.

Sculptor: Dario Bonucchi.

Biographical/
Information: Bonucchi worked for the architectural firm, Giffels and Associates; the firm contacted by United Foundation in Detroit to design the Torch in 1970. In 1973, Bonucchi left Giffels and Associates and as a result, the firm tried in vain to eliminate his name from the list of credits at the base of the Torch. Shortly after this ado, Bonucchi died.

Material/
Technique: Extruded aluminum. The Torch is comprise of three sections and a cap. Each section is joined by a sleeve joint and in the cap a burner is mounted. The exterior finish was sandblasted to create a matte finish and then coated with a clear epoxy-lacquer coating.

Size: 50 feet from base to top of cap.
Weight, 5,000 lbs.

Description: The narrow tall torch is comprised of many shorter superimposed tubular sections, the cap repeats the tubular shapes in silhouette and bears the United Foundation's UF insignia.

Inscription: "This Torch, a symbol of the concern and generosity of the people of this community, glows each year throughout the United Foundation Torch Drive. It's design, construction and erection

are the product of the cooperative spirit of these companies: Giffels Associates, Dario Bonucchi Architect, Reynolds Metals Company, Brooks & Perkins, Inc., Darini & Armstrong, Inc., Detroit Building Trades Council.

**Important
Historical
Facts:**

--The United Foundation (UF), which is the grandfather of all United Way Campaigns in the country, was formed in 1949, and was the first such United Fund Drive in the nation. When the first drive was started, it was thought that some symbol of this effort should be developed to remind the community of the need for a fund-raising drive and to serve as a vehicle that would symbolize the successful attainment of the drive's monetary goal each year. It was decided that a burning torch to be ceremonially lit at the commencement of the United Foundation Dive and kept burning throughout the campaign would be the ideal symbol. Thus, a Torch was constructed --a temporary wooden structure which stood only during the fund-raising period each year and was taken down after the drive concluded. While it served a purpose of drawing attention of the UF appeal and needs during the duration of the annual fundraising drive, because it was disassembled each year, it could only serve as a symbolic reminder during this brief time period. So, in 1970, after about 20 years of use, when the wooden structure of the old United Foundation Torch began to show its years of wear and weathering, it was decided by the UF in Detroit to replace it with a more permanent structure that would serve as a symbol of the spirit and generosity of the communities that are the UF -- not only during the annual fund-raising drive period, but throughout the year.

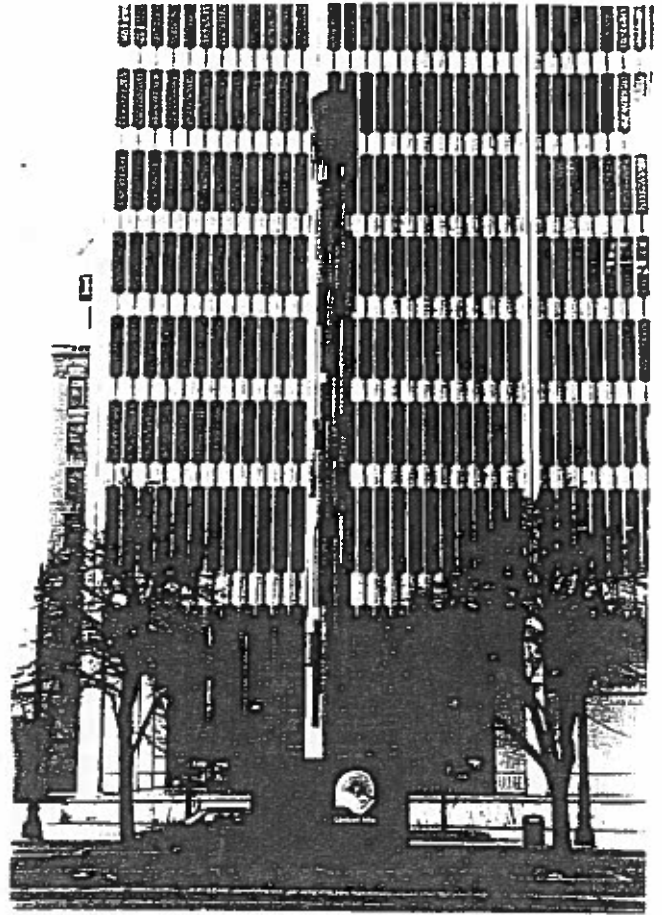
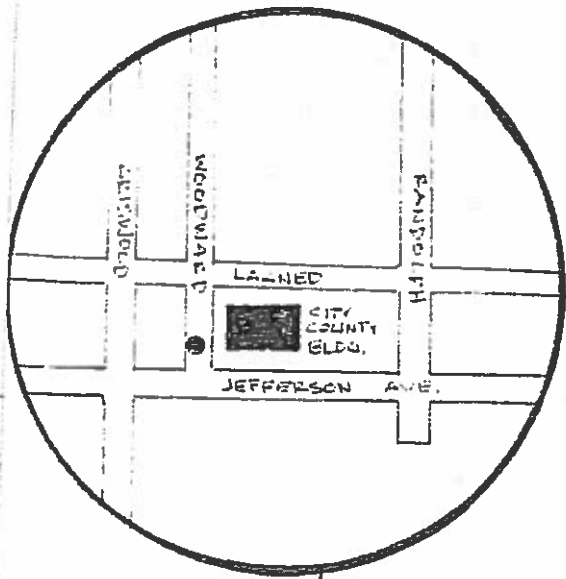

UNITED FOUNDATION TORCH



UNTITLED

(Owned by Practical limited Dividend Housing, but is located on City Property: Parcel 10B)

Location: North side of East Lafayette between St. Maron and Chene (Parkview Place).

Sculptor: James Nani.

Biographical/
Information: Nani was born in New York. Nani lived in Puerto Rico, Mexico, South America, and New York, before settling in Detroit in 1956. At that time he attended Wayne State University.

Material/
Technique: Welded corten steel.

Size: Approximately 15 feet tall.

Description: Curved, ribbon-like steel is fastened at its approximate center, circling and embracing like arms in a dance. The columnar base is also of corten steel. The work is signed by the artist.

Inscription:

Important
Historical
Facts:

- As part of the Elmwood III building project, the architect was required to spend 1% of MISHDA Development Funds on art. To date, the work has not been donated to the City.
- Out of several designs, the Elmwood Citizens District Council, along with Stanley Burger, owner of Practical Limited Dividend Housing, selected this work by Nani in 1979 or 1980.

Department
Responsible
for
Maintenance:

Practical Limited Dividend Housing.

Condition:

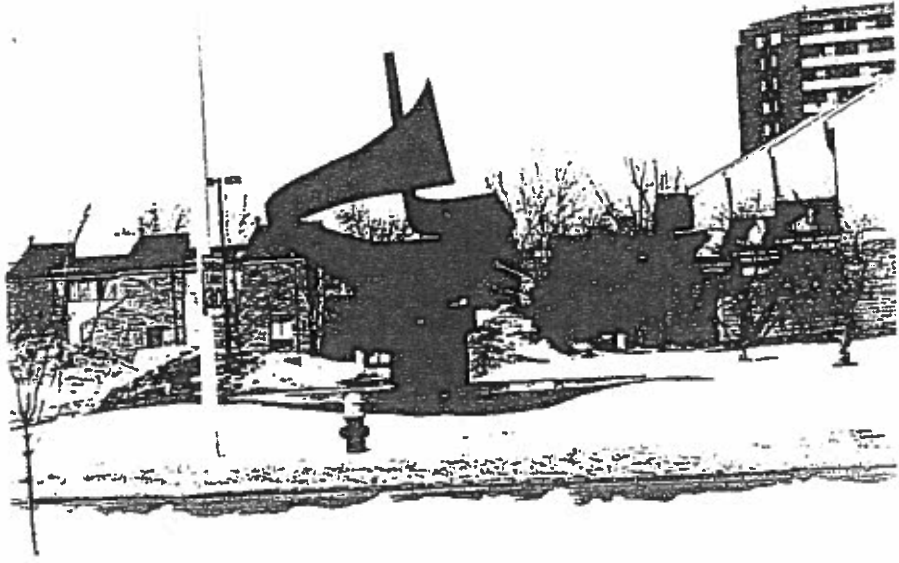
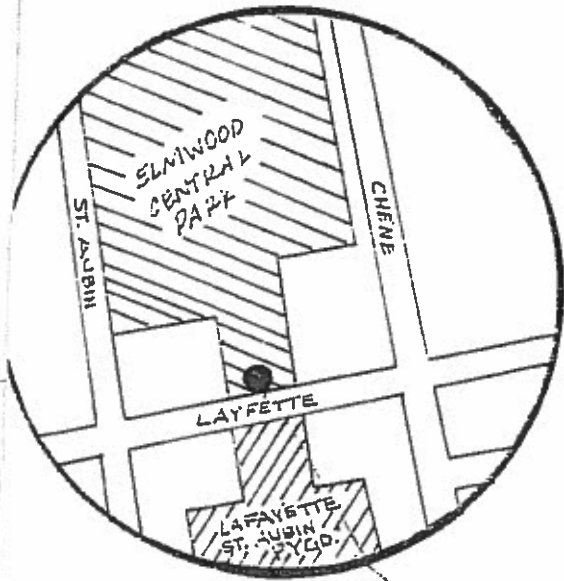

UNTITLED - PARKVIEW PLACE

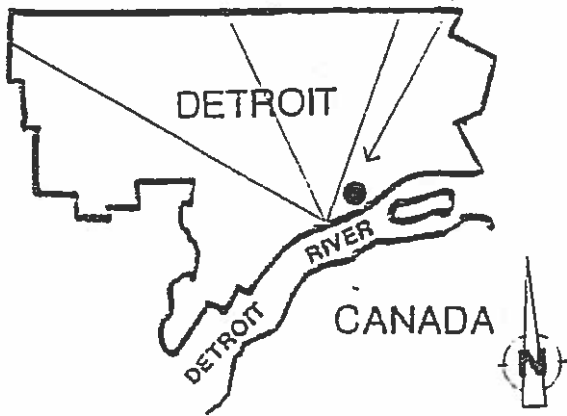

KERN BLOCK SCULPTURE

Location: Middle-south side of Kern Block, bounded by Woodward Avenue, Michigan Avenue, Griswold and Fort Streets.

Sculptor: John Gregory McCarthy.

**Biographical/
Information:** He obtained his B.S. from the University of Arizona, and his M.F.A. from Cranbrook Academy of Art in the mid-1970s. He now resides in the Chicago area.

**Material/
Technique:** Welded corten steel.

Size: Approximately 5" x 5" x 10".

Description: One quarter inch sheets of corten steel enclose two cubular areas, one on top of the other. The sheets have been cutout at selected, usually opposite corners in a semi-circular manner. The result is a varying play of form, movement and stability.

Inscription:

**Important
Historical
Facts:**

--The sculpture was installed during the summer months of 1973, as part of a three-person exhibition sponsored by the Junior League of Detroit in conjunction with the Detroit People's Art Project. The three participating Cranbrook artists were Syd Atkinson, Herbert Babcock, and Greg McCarthy. After the exhibition, McCarthy desired to have this sculpture remain, thus it became the responsibility of the City.

Department
Responsible
for
Maintenance:

Detroit Recreation Department.

Condition:

Fair.

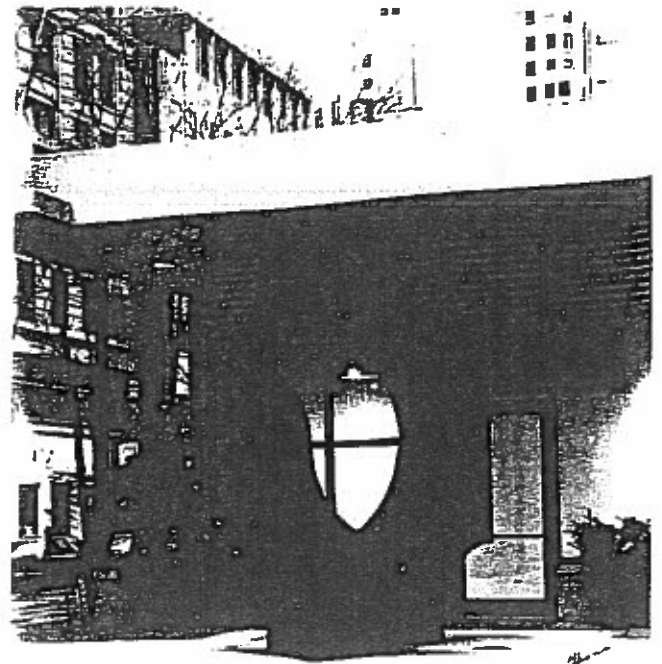
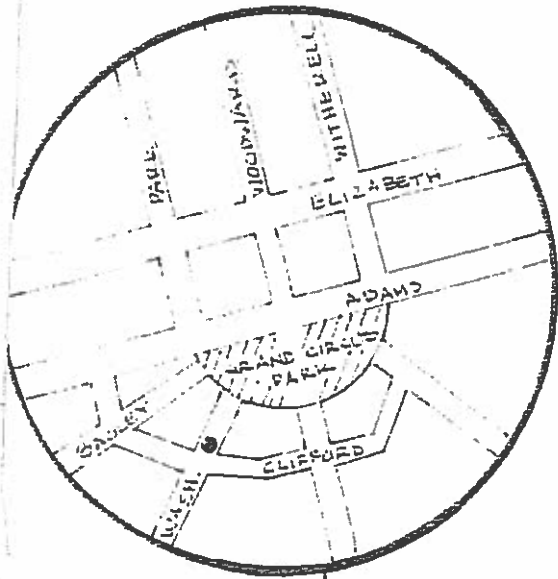

UNTITLED - KERN BLOCK SCULPTURE



UNTITLED

Location: North entrance of Virginia Park, Rosa Parks Boulevard and Clairmont.

Sculptor: John A. Ward.

Biographical/
Information: Originally from the Port Huron area, Ward attended Wayne State University in the 1970s.

Material/
Technique: Welded steel - 1/2 thick, primed and finished with two coats of flat black exterior metal paint.

Size: Approximately 10 ft. tall.

Description: From the side, this flat black structure resembles two diamond-like shapes, one on top of the other. However, it is three sided (like a tripod) and consists of four inverted, cut out pyramids. The multi-faceted work provides the viewer with the kaleidoscope effect of light and shadow, positive and negative space.

Inscription:

Important
Historical
Facts: --This work was chosen as a result of a competition held March 17, 1976. Initiated by the Detroit Recreation Department in connection with the Virginia Park Rehabilitation Project. Jurors for the competition were: Henri Umbagi King, John Neff, Susanne Hilberry, Lillie May Wiley, and James W. Jones.

Department
Responsible
for
Maintenance:

Detroit Recreation Department.

Condition:

Good.

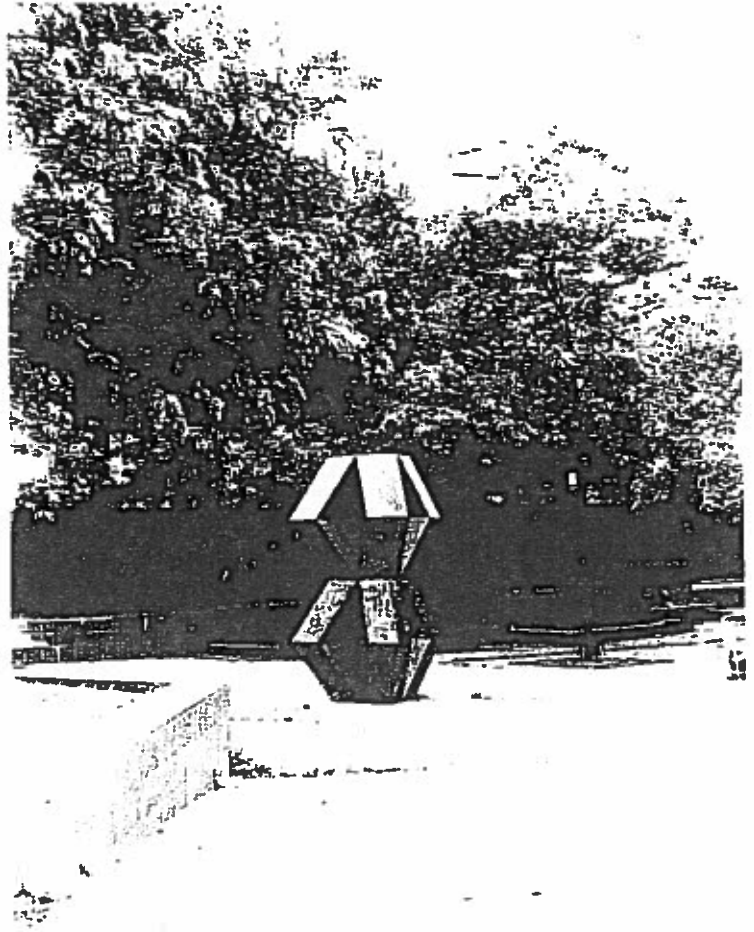
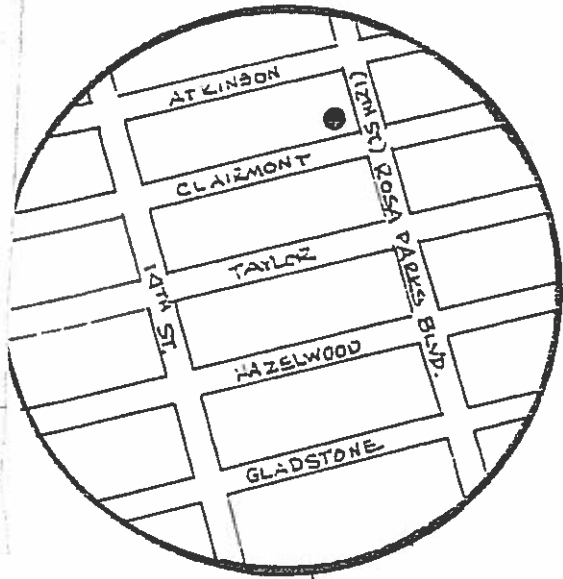

UNTITLED - VIRGINIA PARK



FOUNTAINS

GENERAL RUSSELL A. ALGER MEMORIAL FOUNTAIN

Location: Grand Circus Park, easterly side.

Sculptor: Daniel Chester French. Henry Bacon served as architect, the contractors were Presbrey-Leland Memorials, New York City.

**Biographical/
Information:** 1850-1931. French was born into an established New England family. After an unsuccessful attempt at formal education at the Massachusetts Institute of Technology, French turned his attention to sculpture, falling under the influence of May Alcott, John Quincy Adams Ward and William Rimmer. At the age of twenty-three, he sculpted Minute Man for the town of Concord, Massachusetts. He then spent eighteen months in Italy where the neoclassical mode was prevalent. Later in his career he spent an important year in Paris. Upon his return, French received numerous commissions as his popularity sky-rocketed. The major accomplishments for the first stage of his artistic career were the Alma Mater for Columbia University, the Melvin Memorial and the standing Lincoln in Nebraska. In the last two decades of his life, French explored more fully the possibilities of movement and spatial organization. The Alger Memorial and Abraham Lincoln in Washington D.C. were created during this time.

French played an active role in contemporary art at the turn of the century. He enjoyed social activities and had a number of influential positions. He falls under the influence of Ecole des Beaux Arts style imported from Paris, which incorporated architecture, sculpture, painting, and landscaping into a unified environment. This style was full of rigorous naturalism, richly modeled forms, dramatic poses, and complex compositions.

Material/
Technique:

Cast bronze and Milford granite.

Size:

Statue is 15 ft., base to top. The base stands 5 ft., and the basin is 30 ft. in diameter.

Description:

A bronze woman typifying Michigan holds a shield and sword while her left hand is raised in greeting. On a pedestal which bears a plaque of Alger, lion heads spew out water into a circular basin.

Inscription:

Russell A. Alger - Soldier - Statesman
Citizen - 1836-1907.

Important
Historical
Facts:

- Russell A. Alger was a former Governor of Michigan, a U.S. Senator, and the Secretary of War.
- 1912: Alger Memorial Association was formed. Its leaders were Frank J. Heckler, John Donaldson, and Charles Moore. The Civil War veterans were also active in this commission.
- 1913: French and Bacon were commissioned to do the work.
- The Association delayed the decision of site; consequently, the artist did not begin work until 1919.
- 1921: Fountain was unveiled.
- Restored in 1985 by Venus Bronze Works, Inc. of River Rouge, Michigan.

- More information can be obtained from the file in the Department of Parks and Recreation, as well as in the Public Library - Burton Collection.
- Further reading: Michael Richman, Daniel Chester French, An American Sculptor. New York; Metropolitan Museum of Art, 1976.

Department
Responsible
for
Maintenance:

Detroit Recreation Department.

Condition:

Summer 1987 - vandals broke off a portion of the sword. Therefore, the sword needs to be repaired and washed with re-waxed.

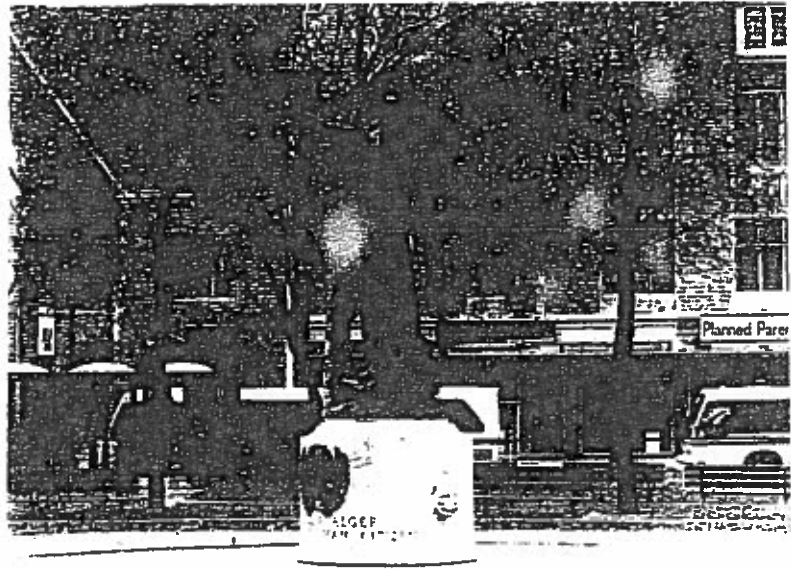
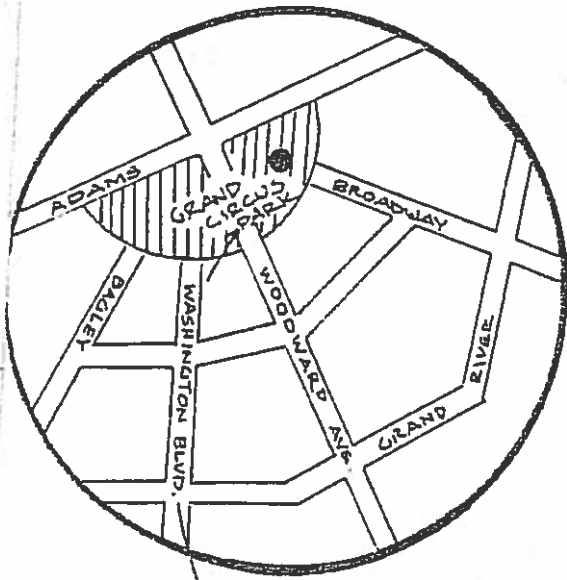

GENERAL RUSSELL A. ALGER
MEMORIAL FOUNTAIN



JOHN JUDSON BAGLEY MEMORIAL DRINKING FOUNTAIN

- Location:** The Kern Block near an area once known as Campus Martius is its present location.
- Sculptor:** Henry Hobson Richardson.
- Biographical/
Information:** Born in 1839, in Brookline Massachusetts, Richardson was a giant in American architecture in the 1870s and 1880s. He was known for transforming architectural design after the Civil War, bringing order out of chaos by simplifying massing. He died in 1886. John Judson Bagley Fountain is the only surviving work of Richardson's in Michigan. Another significant work of his is the famous Trinity Church in Boston.
- Material/
Technique:** White Worcester granite.
- Size:**
- Description:** The fountain is an adaptation of the ciborium in St. Marks Basilica, Venice. Four columns support arches which are surmounted by a sharply pitched triangular roof. The space encompassed is rectangular. The fountain was designed in such a way that it could cool the drinking water by the placement of ice in a system of coils.
- Inscription:**

Important
Historical
Facts:

- \$5,000 was provided in former Michigan Governor John Judson Bagley's will, which stipulated that this fountain should be a public source of drinking water, "cold and pure as the coldest mountain stream." Wisely, the executors of Bagley's will specifically stated that Richardson would be the architect.
- Unveiled May 30, 1887.
- On June 23, 1887, the Council of Detroit first ordered ice to be placed in the fountain.
- It was moved to its present site on July 3, 1926.
- The fountain was boarded up from June 4, 1937 through 1959. It operated sporadically from 1959 until 1983.
- The fountain was designated as a Detroit historic landmark on July 2, 1974.
- Governor Bagley was a very successful and influential tobacco magnate and Detroitier who obviously must have had a sincere concern for people. His accomplishments include: Detroit Alderman, 1860-61; Police Commissioner, 1865-72; influential in the passage of State legislation for the creation of the Detroit Metropolitan Police Commission; co-founder and officer of American Exchange National Bank and Wayne County Savings Bank; first president of the Michigan Mutual Life Insurance Company; and Michigan Governor, 1873-77.
- Originally the fountain was located at the head of West Fort Street near Woodward Avenue on the old City Hall site. The Kern Block near an area once known as Campus Martius is its present location. The site was made available after the Merrill Fountain was moved.

Department
Responsible
for
Maintenance:

Condition:

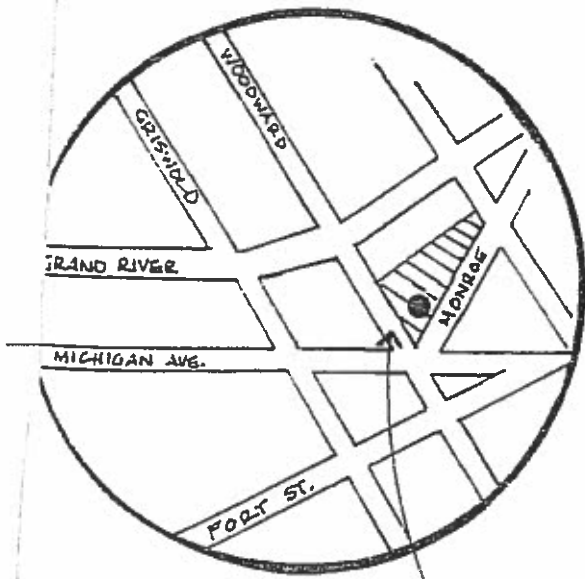

JOHN JUDSON BAGLEY
MEMORIAL DRINKING FOUNTAIN
KERN BLOCK.



HORACE E. DODGE AND SON MEMORIAL FOUNTAIN

Location: Center of Hart Plaza, at the foot of Woodward and Jefferson Avenues.

Sculptor: Isamu Noguchi.

Biographical/
Information: Born in 1904, in Log Angeles, California, Isamu Noguchi has achieved international fame and recognition. His mother was American, his Father Japanese, and as a result, Noguchi's work relates to two cultures. To this day, he works in a studio on the island of Shikoku, Japan, as well as in New York City. Although, he has gained acclaim as a draftsman, stage designer of sculptural backgrounds for Martha Graham and as an industrial designer of lamps and furniture, it is as a sculptor of monumental works that he is best known. In Noguchi's work there exists a harmony with the environment that goes back to nature itself.

Material/
Technique: Constructed of stainless steel.

Size: 30 feet high.

Description: The fountain is of stainless steel, 30-foot above a walled circular black granite pool. The ring is supported on two sparrd legs and studded with computerized nozzles that activate innumerable water configurations according to the temperature. An intricate lighting system illuminates

what appears at night as a spaceship taking off and landing. The Dodge Fountain has more than 300 jets and nozzles and 300 lights. The Dodge Fountain goes for 7 1/2 hours without repeating any configuration.

Inscription: None.

Important
Historical
Facts:

- In 1971, two million dollars was bequeathed to the City by Anna Thompson Dodge in order to construct a fountain at the foot of Woodward Avenue to be known as the Horace E. Dodge and Son Memorial Fountain. (Mrs. Dodge was the wife of the late auto pioneer Horace E. Dodge. She died at age 104 in 1970).
- Costs totaled \$20,668,325.12.
- Groundbreaking ceremony was on October 2, 1975. Mayor Coleman A. Young was joined by council members David Eberhard, Nicholas Hood, Erma Henderson, Carl Levin and Ernest Browne, Jr.
- Completed on October 14, 1981.
- Architect: Smith, Hinchman and Grylls Associates, Inc.
Contractor: John E. Green Plumbing and Heating Co., Inc.
- Artist's statement: "I wanted to make a new fountain, a fountain which represents our times and our relationship to outerspace." Also the mountain represents a source of energy, an engine so deeply a part of Detroit...the dream that has produced the automobile, the airplane and now the rocket, a machine becomes a poem."

Department
Responsible
for
Maintenance:

Civic Center Department.

Condition:

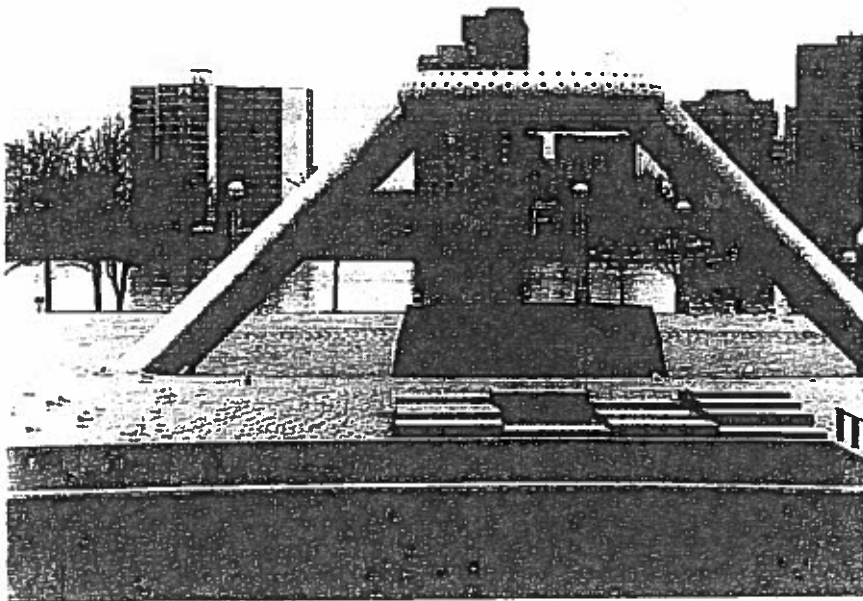
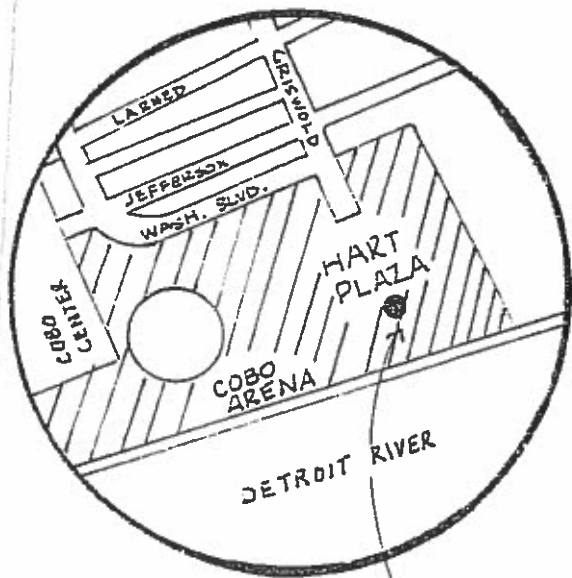

HORACE E. DODGE & SON
MEMORIAL FOUNTAIN
HART PLAZA



EDISON FOUNTAIN

- Location:** Grand Circus Park near Adams Avenue.
- Sculptor:** A number of designers worked on this fountain.
- Biographical/
Information:**
- Material/
Technique:** Indiana limestone and bronze.
- Size:** A 15 h.p. motor operates a Gould enclosed impeller type centrifugal pump having a 5" suction and 5" discharge. The lower reservoir has a capacity of 13,460 gallons. The upper reservoir has a capacity of 23,560 gallons. The lighting is accomplished by 30 projectors having red, white, blue and amber lenses, these units operating on dimmers. There is no revolving multi-colored floodlight used. The equipment was supplied by the General Electric Company. The General Electric designation for it was "The Novalux 30 Projector Electric Fountain."
- Description:** The circular structure surrounding the jets and enclosing the elaborate lighting system, and the basin in the center are Indiana limestone. On the basin is an appropriately inscribed bronze plaque.
- Inscription:** "Erected by the people of the City of Detroit in commemoration of the achievements of electricity. October twenty-first. In the year one thousand nine hundred twenty-nine."

Important
Historical
Facts:

- The fountain had originally been in operation in the East and was purchased through the efforts of the Allied Electrical Industries, who contributed \$25,000, and the Detroit Board of Commerce, who added another \$2,000.
- General Electric Company of Schenectady, New York, furnished most of the electrical equipment.
- It was reassembled in Grand Circus Park to commemorate "Lights Golden Jubilee" in 1929, by the Detroit Edison Company. The "Lights Golden Jubilee" commemorated the 50th Anniversary of Thomas A. Edison's invention of the first practical incandescent electric lamp. Thomas Edison and President Herbert Hoover attended the dedication ceremonies on October 21, 1929.
- When Edison died in 1931, the lights were turned on during the funeral services in his memory.
- On October 18, 1984, the fountain was rededicated after extensive repair.

Department
Responsible
for
Maintenance:

Detroit Recreation Department.

Condition:

Excellent.

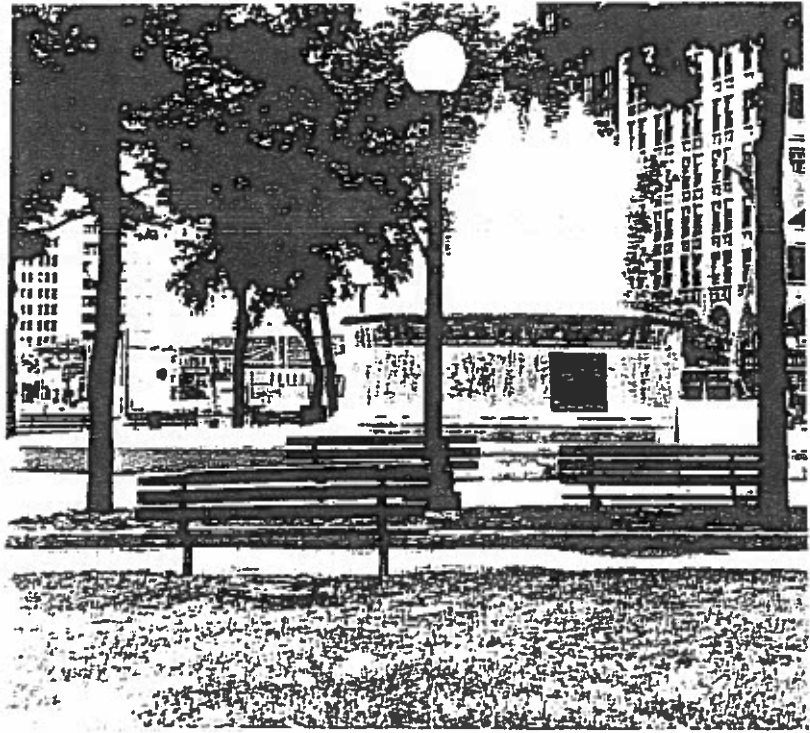
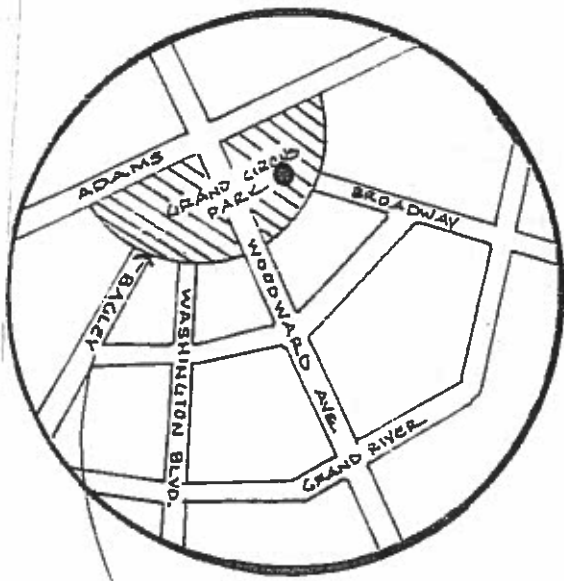

EDISON FOUNTAIN



GEORGE JAY MARON MEMORIAL FOUNTAIN

Location: Northwestern Field.

Sculptor: Unknown.

Biographical/
Information:

Material/
Technique: Brown polished marble drinking fountain
on marble base. Marble plaque.

Size: 14" x 38".

Description:

Inscription: (on fountain) (cut in letters)
George J. Maron. George Jay Maron -
Born New York, N.Y. April 3, 1885. Died
Detroit, Michigan, February 3, 1944.
This memorial is gratefully dedicated by
the People to the memory of shorty rec-
ognized by Detroit youth as their cham-
pion of the sandlots of this City as a
co founder of Detroit Federation. He
was president 1920-1944.

Important
Historical
Facts:

Department
Responsible
for
Maintenance:

Condition: Good.

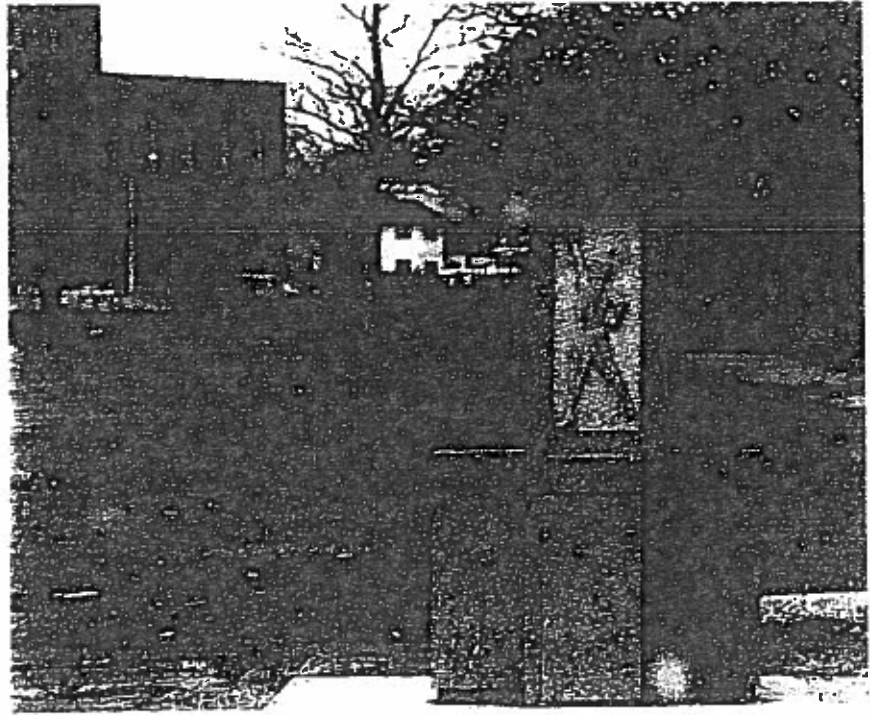
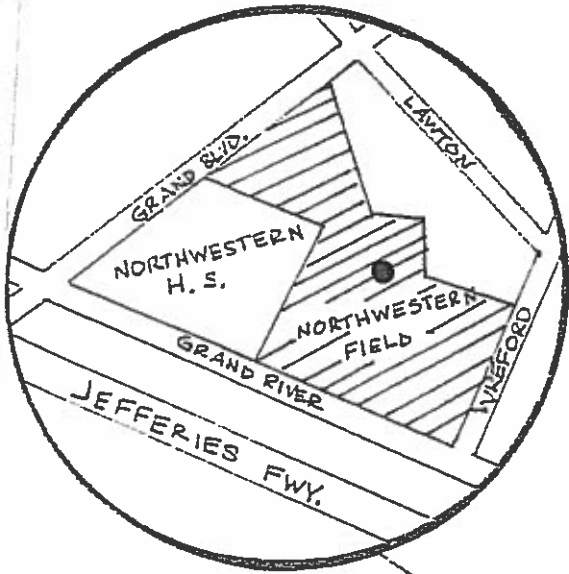

GEORGE JAY MARON MEM. FOUNTAIN
NORTHWESTERN FIELD



MERRILL MEMORIAL FOUNTAIN

- Location:** Palmer Park, south end of park near Merrill Plaisance between Second and Third Avenues.
- Sculptor:** John M. Carrere and Thomas Hastings.
- Biographical/
Information:** Carrere and Hastings operated an architectural firm based in New York. Both men are graduates of the Ecole des Beaux-Arts in Paris, and the rich ornamentation of this fountain certainly reveals their French orientation. Their achievements include designing the New York Public Library. Carrere lived from 1858-1911; Hastings from 1860-1929. Mr. Zack Rice represented the firm in Detroit.
- Material/
Technique:** Marble.
- Size:**
- Description:** The dominant shape is a semi-circle which is repeated in the overlapping basins and baldachin. Decorative elements include an enclosed shell with aquatic animals, twin dolphins, King Neptune, and maned lions flanking the sides. An elaborate balustrade embraces the structure.
- Important
Historical
Facts:**
- In 1894, Mrs. Lizzie M. Palmer offered to build a drinking fountain on Campus Martius in Detroit.
 - 1897-1898, the site was discussed and plans reviewed. The so-called Opera House Crossing at Woodward and Campus Martius was the determined location.

- 1899, plans of Carrer and Hastings, presented by Zack Rice, were discussed.
- 1901, the fountain was completed and accepted by the City. It was dedicated to Charles Merrill (1792-1892), an early Detroit lumber baron, who was the grandfather of the donor, Mrs. Lizzie Palmer. Senator Thomas W. Palmer was the donor's husband.
- It was decided that due to the need of additional space by the City, the fountain should be moved. Senator Palmer had donated 130 acres of land north of the city, which eventually became Palmer Park, and it was suggested that this would be an ideal location. The cost of the move was approximately \$18,600. The Detroit Granite Company, and Department of Parks and Boulevards were responsible for the relocation process.
- In 1950, a report was filed by the City Engineer's Office reporting that the fountain required major repairs and renovation at a cost of \$35,000. No action was taken at the time.
- In 1957, some work was done to keep the structure safe.

Department
Responsible
for
Maintenance:

Detroit Recreation Department.

Condition:

Inoperable, very poor.

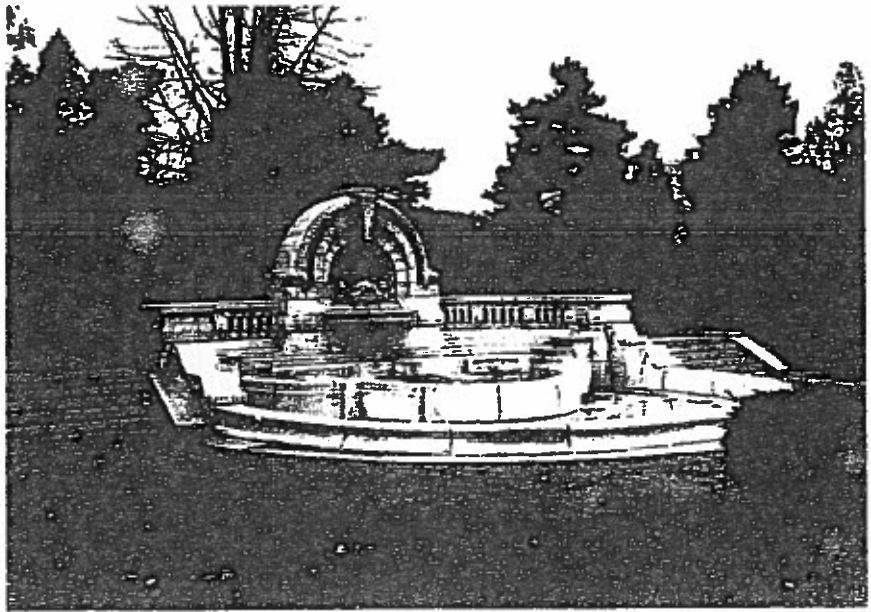

MERRILL MEMORIAL
FOUNTIAN

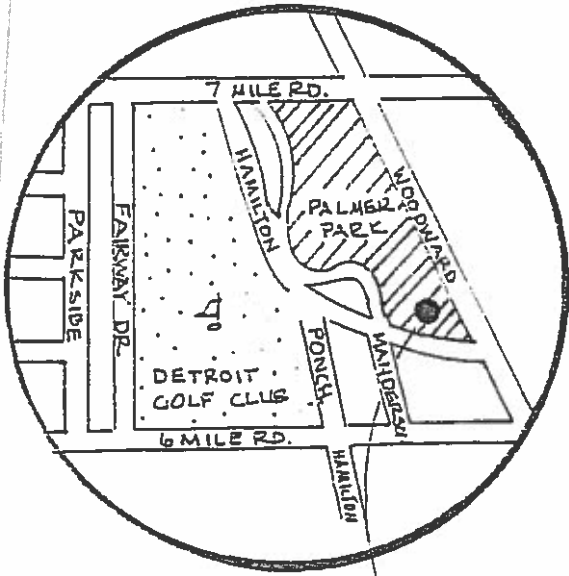

FRANK G. McINNIS MEMORIAL FOUNTAIN

- Location:** East side of Penquinarium, Zoological Gardens, 8450 West Ten Mile Road, Royal Oak.
- Sculptor:** Samuel Cashwen and Martin Dugalin.
- Biographical/
Information:** Cashwan was born in Cherkassi, Russia, in 1900, and studied art in New York and Paris. Having first taught architectural sculpture at the University of Michigan, in 1927, he joined the faculty of the Detroit Society of Arts and Crafts as head of the Sculpture Department. He was the WPA-Federal Art Project Supervisor in sculpture in Michigan during the Depression. In 1942, he became a designer at General Motors Corporation. Having received many commissions, examples of his work are numerous in this area. The James J. Brady Memorial Monument, and the Rev. Samuel Francis Smith Flag pole by Cashwan are also owned by the City of Detroit.
- Dugalin did the pool tiling. Born in Austria, he started work as a shoemaker, but later turned to tile setting. He is also responsible for a lot of tile work in the area.
- Material/
Technique:** Stone, cement and mosaic tile.
- Size:** Approximately four feet high.
- Description:** The six-footed urn has a lime green background with dark green or black chips of mica type stone imbedded into the surface. A parade of penguins marches around the top portion. The inside the urn is lined with ceramic tile.

Inscription: None.

Important
Historical
Facts:

- Frank G. McInnis was at one time the director of the Zoo.
- The monument was paid for by contributions by friends and colleagues. His wife chose the artist.
- It was dedicated on August 28, 1969.

Department
Responsible
for
Maintenance:

Zoological Gardens.

Condition:

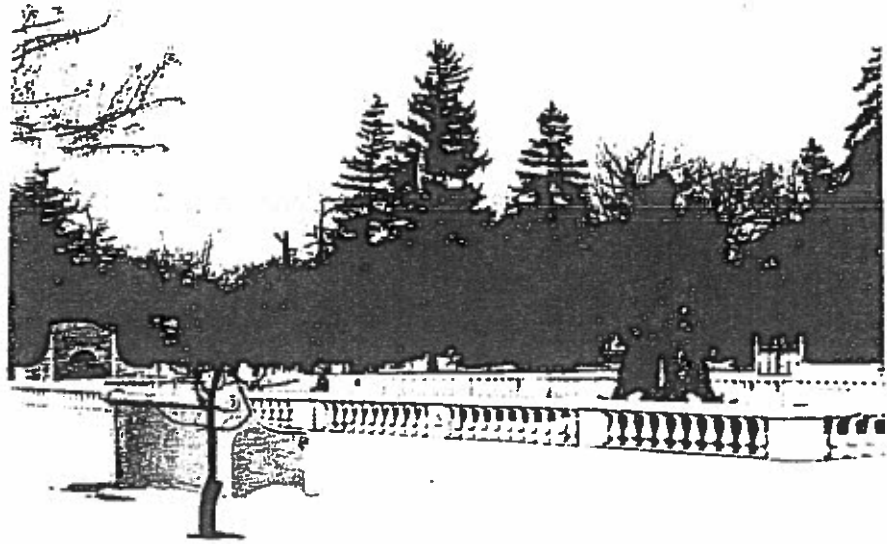
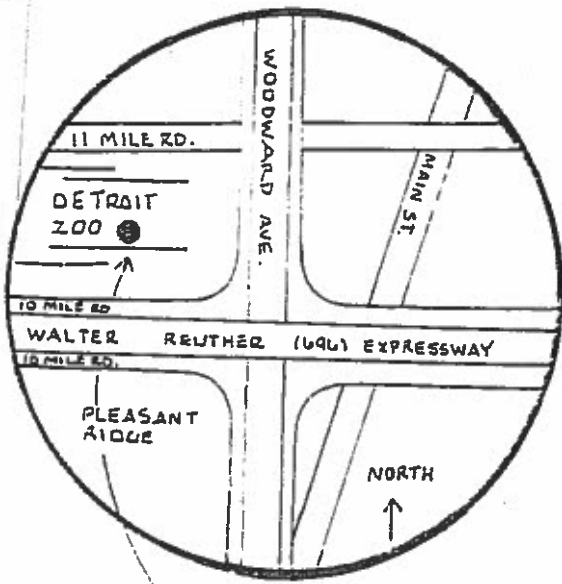

FRANK G. MCINNIS
MEMORIAL FOUNTAIN



ORCHESTRA HALL FOUNTAIN

Location: Woodward Avenue and Selden Street.

Sculptor: John N. Grissim.

Biographical/
Information: Grissim is the principal architect of John Grissim and Associates, Inc. of Farmington Hills, Michigan. He received his B.S. in Landscape Architecture in 1953, from Michigan State University. He went on to obtain his M.L.A. from the University of Michigan. In 1979, he was the recipient of the Distinguished Alumni Award from Michigan State University. and in 1984, he was awarded a national award from the White House for his outstanding work in his field.

Material/
Technique: Cut and welded stainless steel.

Size: The four panels are each approximately 13 1/2 feet tall.

Description: Four panels stand independently of each other. Each panel contains cut out variations of the letter "C". From a distance, the cut out patterns blend together to form the musical symbols, the treble and bass clef, which is appropriate for their location near Orchestra Hall. Water is forced through the apex of the structure.

Inscription: None.

Important
Historical
Facts: --In the spring of 1982, the City of Detroit contracted Grissim Associates to design a park surrounding the area

where the sculpture now stands. This plan with the fountain was estimated to cost \$240,000. However, because of \$40,000 needed to repair the area sidewalk, it was suggested the \$42,000 sculpture not be built.

--Determined to have the sculpture built, John Grissim went to private industry, resulting in Ryerson Steel discounting their steel cutting price to \$3,500, the American Welding Society paid Paul Boes, an award winning welder from St. Clair, \$1,500 to put the sculpture together, Clawson Concrete of Oak Park donated concrete, and Alva Greer Concrete Company of Fraser contributed \$1,600 in labor to pour the concrete. Also, Brooks Irrigation donated \$12,000 in labor to install the fountain and coordinate the mechanical work. Finally, thirty individuals donated time and materials to make the project a reality. Grissim's general efforts went beyond the call of duty.

--It was dedicated in September, 1983.

Department
Responsible
for
Maintenance:

Detroit Recreation Department.

Condition:

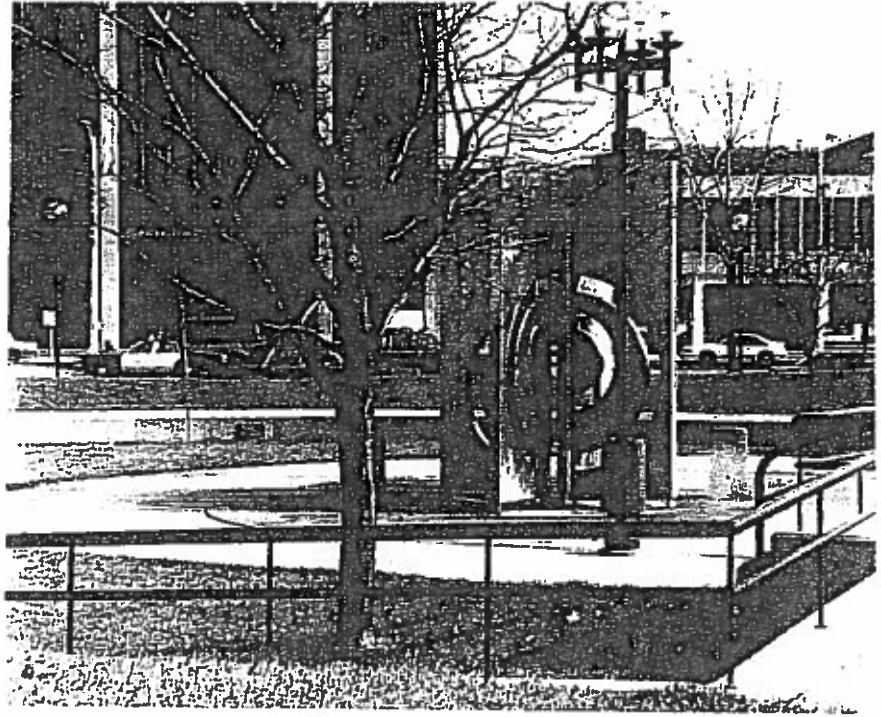
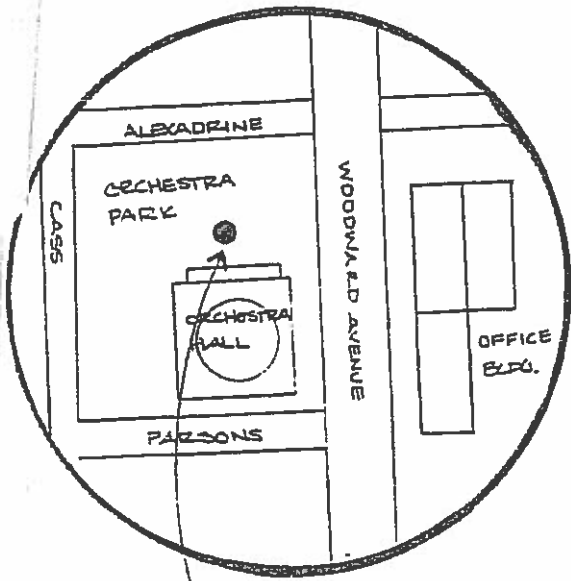

ORCHESTRA HALL FOUNTAIN



ATTACHMENT III

ART INVENTORY : Detroit-Wayne Joint Building Authority

Coleman A. Young Municipal Center

Status July 2015

DWJBA OWNERSHIP/POSSESSION	Current Location	Proposed Use	Action
1 Father and Mother Teaching a Lesson in Charity	Vault	Gift/Fredericks Museum	Delivered
2 Justice and Knowledge Imparted to Youth	Vault	Gift/Fredericks Museum	Delivered
3 Justice is Served While Employing Compassion and Kindness	Vault	Gift/Fredericks Museum	Delivered
4 Justice Encompasses Knowledge and Technology	Vault	Gift/Fredericks Museum	Delivered
5 Portrait of an Unidentified Judge	Vault	TBD	
10 Bust of Hazen S. Pingree	Lobby	Retain/Lobby	
11 Bust of Edward J. Jeffries, Jr.	Lobby	Retain/Lobby	
12 Bust of Eugene I Van Antwerp	Lobby	Retain/Lobby	
13 Bust of John W. Smith	Lobby	Retain/Lobby	
14 Portrait of Ira Waite Jayne	Vault	TBD	
15 Relief Portrait of Jerome P. Cavanagh	Lobby	Retain/Lobby	
16 Detroit Cityscape	Vault	TBD	
17 View of the Detroit Skyline from the Detroit River looking North	Vault	TBD	
18 Fake Declaration of Independence	Vault	TBD	
19 Portrait of Roman S. Gribbs	Vault	Returned/Dist Hist Soc 6-15	Delivered
20 Portrait of Louis C. Miriani	Vault	TBD	
21 Portrait of Honorable Frank Murphy	Vault	TBD	
22 Portrait of Albert Cobo	Cobo Center	Loaned to DRCFA (Cobo)	Delivered
23 Lake Freighter	Vault	TBD	
24 Bust of Coleman A. Young	Lobby	Retain/Lobby	
26 Spirit of Detroit	Woodward Ave Ent	Retain/Woodward	
CITY OF DETROIT OWNERSHIP			
6 Portrait of Mary V. Beck	City Council	Proposed Use	
7 Portrait of Erma Lois Henderson	City Council	City Council	
8 Portrait of Maryann Mahaffey	City Council	City Council	
9 Seal of the City of Detroit	City Council	City Council	
COUNTY OF WAYNE OWNERSHIP			
25 Portrait of Frank Fitzgerald	Suite 780 Library	Proposed Use	
27 Judge Shamansky (AKA Judge Szymanski, Sr)	Owned by Judge David Szymanski and removed when he vacated	Wayne County	
LOAN: From the DRCFA (Cobo) Portrait of Coleman A. Young (CAY)			
	Atrium-Auditorium	Display	Received

1,2,3,4,5 Plaster molds discovered in basement storage and gifted for display to the Marshal Fredericks Museum